

Job Name/Location:

Tag #:

Date:

For: File Resubmit
 Approval Other _____

PO No.:

Architect:

GC:

Engr:

Mech:

Rep:

(Company)

(Project Manager)

LD097HV4

Single Zone Low Static Duct

Outdoor Unit (ODU) - LUU097HV Indoor Unit (IDU) - LDN097HV4



Performance:

Cooling:

Capacity (Min-Rated-Max, Btu/h)	3,600 - 9,000 - 9,900
SEER/EER	18.5/12.7

SEER - Seasonal Energy Efficiency Ratio EER - Energy Efficiency Ratio

Heating:

Capacity (Min-Rated-Max, Btu/h)	5,600 - 14,000 - 15,400
HSPF	10.3

HSPF - Heating Seasonal Performance Factor

Cooling Nominal Test Conditions:

Indoor: 80°F DB/67°F WB

Outdoor: 95°F DB/75°F WB

Heating Nominal Test Conditions:

Indoor: 70°F DB/60°F WB

Outdoor: 47°F DB/43°F WB

Electrical:

Power Supply ¹ (V/Hz/Ø)	208-230/60/1
MOP (A)	15
MCA (A)	11.9
Cooling Rated Amps (A)	9.65
Heating Rated Amps (A)	9.65
Compressor (A)	9.0
Fan Motor (IDU+ODU) (A)	0.65
Cooling Power Input (kW)	0.71
Heating Power Input (kW)	1.43

MOP - Maximum Overcurrent Protection MCA - Minimum Circuit Ampacity

Piping:

Liquid Line (in, OD)	1/4
Vapor Line (in, OD)	3/8
Additional Refrigerant (oz/ft)	0.22
Max Pipe Length ² (ft)	66
Pipe Length (no add'l Refrigerant, ft)	24.6
Max Elevation (ft)	49

Features:

- ESP control
- Hot start
- Inverter (variable speed fan)
- Internal condensate pump
- Auto restart
- Control lock
- Group control
- Timer (on/off)
- Sleep mode
- Optional Wi-Fi control

Required Accessories (sold separately):

Controller (Any LG wired remote controller)

Optional Accessories:

- MultiSITE™ CRC1 - PREMTBVC0
- MultiSITE CRC1+ - PREMTBVC1
- MultiSITE Comm. Mgr. - PBACNBTR0A
- PI-485 - PMNFP14A1
- Dry Contact - PDRYCB300
- Wi-Fi Module - PWFMD200
- Drain Pan Heater for 18k - PQSH1200
- Low Ambient Wind Baffle (Cooling operation to -4°F) - ZLABGP01A
- Simple Controller with Mode (White) PQRVCVCLQW

Operating Range:

Outdoor Unit:

Cooling (°F DB)	0-118
Heating (°F WB)	-4-64

Indoor Unit:

Cooling (°F WB)	57-77
IDU Heating (°F DB)	59-81

Unit Data:

Refrigerant Type/Control	R410A/EEV
Refrigerant Charge (lbs)	2.43
ODU Sound Pressure ³ Max (Cool/Heat)	47/51
IDU Sound Pressure ³ (H/M/L)	30 / 26 / 23
ODU Net Weight (lbs)	82
ODU Shipping Weight (lbs)	89
IDU Net Weight (lbs)	39
IDU Shipping Weight (lbs)	46

Fan:

ODU/IDU Fan Type	Propeller/Sirocco
Fan Speeds (Fan/Cooling/Heating)	3/3/3
Fan Quantity (ODU + IDU)	1 + 2
Motor/Drive	Brushless Digitally Controlled/Direct
ODU Air Circulation (CFM)	988
IDU Air Circulation H/M/L (CFM)	318 / 247 / 194
Factory Set External Static Pressure (in wg)	0.1
Minimum External Static Pressure	0.0
Maximum External Static Pressure	0.2
Dehumidification Rate (pts/hr)	1.5

Notes:

1. Acceptable operating voltage: 187V-253V.
2. Piping lengths are equivalent.
3. Sound Pressure levels are tested in an anechoic chamber under ISO Standard 1996.
4. Maximum static pressure may result in reduced airflow (CFM).
5. All power/communication cable to be minimum 18 American wire gage (AWG), 4-conductor, stranded, shielded or unshielded wire and must comply with applicable local and national code. If shielded, the wire must be grounded to the chassis at the outdoor unit only.
6. See Engineering Manual for sensible and latent capacities.
7. Power wiring cable size must comply with the applicable local and national code.
8. The indoor unit comes with a dry helium charge.
9. This data is rated 0 ft above sea level, with 25 ft of refrigerant line and a 0 ft level difference between outdoor and indoor units.
10. Must follow installation instructions in the applicable LG installation manual.



Outdoor Unit (ODU) - LUU097HV

Single Zone Low Static Duct



Tag #:

Date:

PO No.:

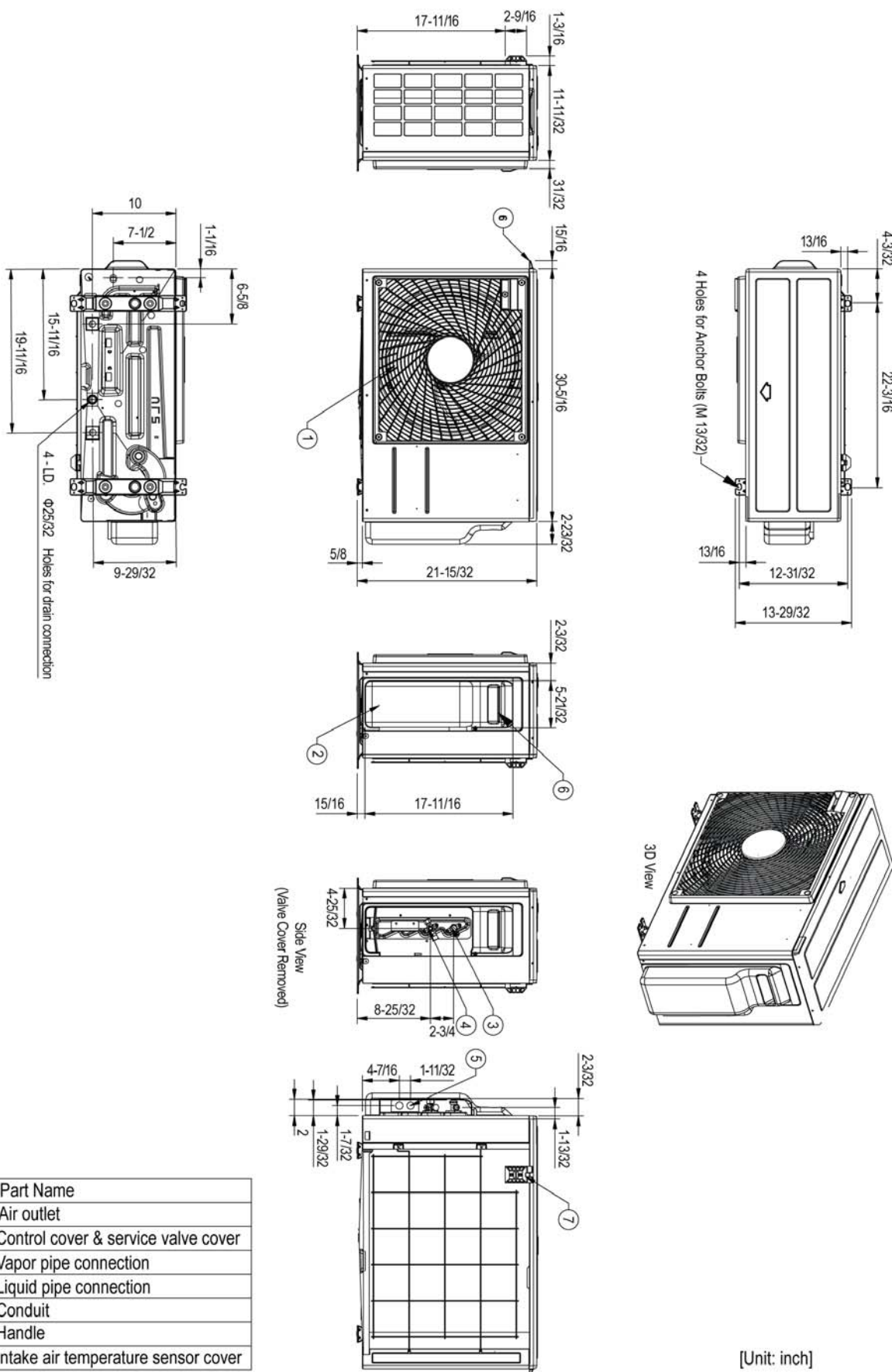

No.	Part Name
1	Air outlet
2	Control cover & service valve cover
3	Vapor pipe connection
4	Liquid pipe connection
5	Conduit
6	Handle
7	Intake air temperature sensor cover

[Unit: inch]

Indoor Unit (IDU) - LDN097HV4

Single Zone Low Static Duct

Tag #:

Date:

PO No.:

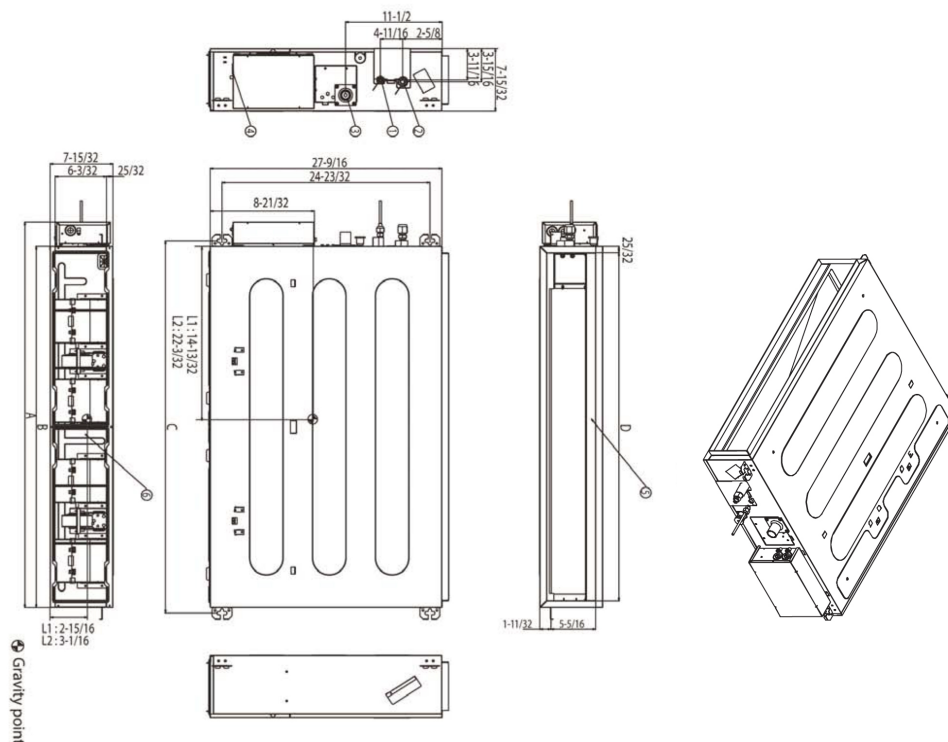

Gravity point

Number	Name	Description
1	Liquid pipe connection	
2	Gas pipe connection	
3	Drain pipe connection	
4	Power supply connection	
5	Air discharge	
6	Air suction	

(unit: inch)

Model Number	A	B	C	D
LDN097HV4	30-15/32	27-9/16	28-27/32	25-31/32
LDN127HV4	38-11/32	35-7/16	36-23/32	33-27/32

(unit: inch)