



# MULTI F

# MULTI F MAX

## OUTDOOR UNIT INSTALLATION MANUAL

**Multi-Zone Heat Pump Systems**  
**1.5 to 5 Tons**



Dual and Tri-Zone  
Multi F



Quad-Zone  
Multi F



Eight-Zone  
Multi F MAX

## PROPRIETARY DATA NOTICE

**This document, as well as all reports, illustrations, data, information, and other materials are the property of LG Electronics U.S.A., Inc., and are disclosed by LG Electronics U.S.A., Inc. only in confidence.**

**⊘ Do not throw away, destroy, or lose this manual.  
Please read carefully and store in a safe place for future reference.  
Content familiarity is required for proper installation.**

The instructions included in this manual must be followed to prevent product malfunction, property damage, injury, or death to the user or other people. Incorrect operation due to ignoring any instructions will cause harm or damage. The level of seriousness is classified by the symbols described by the summary list of safety precautions on page 4.

**For more technical materials such as submittals, catalogs, engineering, owner's, best practices, building ventilation guide, and service manuals, visit [www.lghvac.com](http://www.lghvac.com).**





For continual product development, LG Electronics U.S.A., Inc. reserves the right to change specifications without notice.

© LG Electronics U.S.A., Inc.

<b>Safety Instructions</b> .....	<b>4-7</b>
<b>Nomenclature</b> .....	<b>8</b>
<b>General Data</b> .....	<b>9-19</b>
<b>Installation</b> .....	<b>20-33</b>
<i>Transporting / Lifting</i> .....	20
<i>Placement Considerations</i> .....	21-30
<i>Mounting / Anchoring</i> .....	31-33
<b>General Refrigerant Piping System Information</b> .....	<b>34-48</b>
<i>LATS</i> .....	34-35
<i>Refrigerant Safety/Device</i> .....	36-37
<i>Selecting Copper Piping</i> .....	38
<i>Copper Expansion/Contraction</i> .....	39-41
<i>Piping Handling</i> .....	42
<i>Refrigerant System Engineering</i> .....	43-46
<i>Flaring and Brazing Procedures</i> .....	47-48
<b>Refrigerant Piping System Installation</b> .....	<b>49-57</b>
<i>Installing Multi F Systems</i> .....	49-50
<i>Installing Multi F MAX Systems</i> .....	51-55
<i>Bundling/SpecialApps</i> .....	56
<i>Condensate Drain Piping</i> .....	57
<b>Insulation</b> .....	<b>58-60</b>
<b>Electrical</b> .....	<b>61-76</b>
<i>General Information</i> .....	61
<i>Connections and Specifications</i> .....	62-65
<i>Installation</i> .....	66-76
<b>Final Installation Procedures</b> .....	<b>77-91</b>
<i>Triple Leak / Pressure Test</i> .....	77-78
<i>Deep Evacuation Test</i> .....	78-79
<i>Triple Evacuation Test</i> .....	79-80
<i>Refrigerant Charge</i> .....	81-83
<i>Cautions for Refrigerant Leaks</i> .....	84-85
<i>Test Run</i> .....	86
<i>DIP Switch Settings for Optional Modes</i> .....	87-91
<b>Error Codes</b> .....	<b>92-93</b>
<b>LGMV Diagnostic Software</b> .....	<b>94-95</b>
<b>LG SIMS</b> .....	<b>96-97</b>
<b>Maintenance Recommendations</b> .....	<b>98</b>
<b>Checklists and Worksheets</b> .....	<b>99-104</b>


The instructions below must be followed to prevent product malfunction, property damage, injury or death to the user or other people. Incorrect operation due to ignoring any instructions will cause harm or damage. The level of seriousness is classified by the symbols described below.


## TABLE OF SYMBOLS

 <b>DANGER</b>	<i>This symbol indicates an imminently hazardous situation which, if not avoided, will result in death or serious injury.</i>
 <b>WARNING</b>	<i>This symbol indicates a potentially hazardous situation which, if not avoided, could result in death or serious injury.</i>
 <b>CAUTION</b>	<i>This symbol indicates a potentially hazardous situation which, if not avoided, may result in minor or moderate injury.</i>
<b>Note:</b>	<i>This symbol indicates situations that may result in equipment or property damage accidents only.</i>
	<i>This symbol indicates an action must not be completed.</i>


## Installation

### DANGER

 **Do not store or use flammable gas or combustibles near the unit.**  
*There is risk of fire, explosion, and physical injury or death.*

 **Do not supply power to the unit until all wiring and piping are completed or reconnected and checked.**  
*There is risk of physical injury or death due to electric shock.*

### WARNING

 **Do not install or remove the unit by yourself (end user). Ask the dealer or a trained technician to install the unit.**  
*Improper installation by the user will result in fire, explosion, electric shock, physical injury or death.*

**For replacement of an installed unit, always contact an LG trained service provider.**  
*There is risk of fire, electric shock, explosion, and physical injury or death.*

**Wear protective gloves when handling equipment. Sharp edges will cause personal injury.**


 **Do not change the settings of the protection devices.**  
*If the protection devices have been bypassed or is forced to operate improperly, or parts other than those specified by LG are used, there is risk of fire, electric shock, explosion, and physical injury or death.*

**Replace all control box and panel covers.**  
*If cover panels are not installed securely, dust, water and animals will enter the outdoor unit, causing fire, electric shock, and physical injury or death.*

**Always check for system refrigerant leaks after the unit has been installed or serviced.**  
*Exposure to high concentration levels of refrigerant gas will lead to illness or death.*

**Periodically check that the outdoor frame is not damaged.**  
*There is a risk of explosion, physical injury, or death.*


**If the air conditioner is installed in a small space, take measures to prevent the refrigerant concentration from exceeding safety limits in the event of a refrigerant leak.**  
*Consult the latest edition of ASHRAE (American Society of Heating, Refrigerating, and Air Conditioning Engineers) Standard 15. If the refrigerant leaks and safety limits are exceeded, it could result in personal injuries or death from oxygen depletion.*

**The branch distribution (BD) unit must be installed indoors;**  
 **do not install the BD unit in a highly humid environment.**  
*There is risk of physical injury or death due to electric shock.*

### **Dispose the packing materials safely.**

- Packing materials, such as nails and other metal or wooden parts, will cause puncture wounds or other injuries.
- Tear apart and throw away plastic packaging bags so that children will not play with them and risk suffocation and death.

**Install the unit considering the potential for strong winds or earthquakes.**  
*Improper installation will cause the unit to fall over, resulting in physical injury or death.*

**Install the unit in a safe location where nobody can step, fall onto it, or place objects on it.**  **Do not install the unit on a defective stand.**  
*It will result in an accident that causes physical injury or death.*



---

---

## Installation, continued

### ⚠ WARNING

**Properly insulate all cold surfaces to prevent “sweating.”**

*Cold surfaces such as uninsulated piping can generate condensate that could drip, causing a slippery surface that creates a risk of slipping, falling, and personal injury.*

---

### ⚠ CAUTION

**Be very careful when transporting the product. There is a risk of the product falling and causing physical injury.**

- Use appropriate moving equipment to transport each frame; ensure the equipment is capable of supporting the weights listed.
- Some products use polypropylene bands for packaging. Ⓣ Do not use polypropylene bands to lift the unit.
- Support the outdoor unit a minimum of four points to avoid slippage from rigging apparatus.

---

## Note:

LG Electronics U.S.A., Inc., is not responsible for any piping calculations, refrigerant leaks, degradation of performance, or any other potential problems or damages as a result of interconnecting piping, their joint connections, isolation valves, introduced debris inside the piping system, or other problems caused by the interconnecting piping system.

Ⓣ Do not install the product where it is exposed directly to ocean winds.

*Sea salt in the air will cause the product to corrode. Corrosion, particularly on the condenser and evaporator fins, could cause product malfunction or inefficient operation.*

**When installing the outdoor unit in a low-lying area, or a location that is not level, use a raised concrete pad or concrete blocks to provide a solid, level foundation.**

*This prevents water damage and abnormal vibration.*

**Properly insulate all cold surfaces to prevent “sweating.”**

*Cold surfaces such as uninsulated piping can generate condensate that will drip and cause water damage to walls.*

**Always check for system refrigerant leaks after the unit has been installed or serviced.**

*Low refrigerant levels will cause product failure.*

**The branch distribution (BD) unit must be installed indoors;**

Ⓣ Do not install the BD box in a highly humid environment. *There is risk of product failure and property damage.*

Ⓣ Do not make refrigerant substitutions. Use R410A only. *If a different refrigerant is used, or air mixes with original refrigerant, the unit will malfunction and be damaged.*

Ⓣ Do not store or use flammable gas / combustibles near the unit.

*There is a risk of product failure.*

Ⓣ Do not use the product for mission critical or special purpose applications such as preserving foods, works of art, or other precision air conditioning applications. The equipment is designed to provide comfort cooling and heating. *There is risk of property damage.*

**Keep the unit upright during installation to avoid vibration or water leakage.**

**When connecting refrigerant tubing, remember to allow for pipe expansion.**

*Improper piping will cause refrigerant leaks and system malfunction.*

Ⓣ Do not install the outdoor unit or BD unit in a noise-sensitive area.

**Take appropriate actions at the end of HVAC equipment life to recover, recycle, reclaim or destroy R410A refrigerant according to applicable U.S. Environmental Protection Agency (EPA) rules.**

**Periodically check that the outdoor frame is not damaged.**

*There is a risk of equipment damage.*

**Install the unit in a safe location where nobody can step on or fall onto it. Ⓣ Do not install the unit on a defective stand.** *There is a risk of unit and property damage.*

**Install the drain hose to ensure adequate drainage.**

*There is a risk of water leakage and property damage.*

## Wiring

### ⚠ DANGER

**High voltage electricity is required to operate this system. Adhere to the NEC code and these instructions when wiring. Improper connections and inadequate grounding can cause accidental injury or death.**

**Always ground the unit following local, state, and NEC codes. There is risk of fire, electric shock, and physical injury or death.**

**Turn the power off at the nearest disconnect before servicing the equipment. Electrical shock can cause physical injury or death.**

**Properly size all circuit breakers or fuses. There is risk of fire, electric shock, explosion, physical injury or death.**

⊘ **Do not share the electrical circuit with other appliances. There is risk of fire, electric shock, and physical injury or death due to heat generation.**

⊘ **Do not use damaged or loose power wiring. ⊘ Do not randomly modify or extend the outdoor unit's power wiring. Ensure that the power wiring will not be pulled nor weight be placed on the power wiring during operation. There is risk of fire, electric shock, and physical injury or death.**

### ⚠ WARNING

**The information contained in this manual is intended for use by an industry-qualified, experienced, certified electrician familiar with the U.S. National Electric Code (NEC) who is equipped with the proper tools and test instruments. Failure to carefully read and follow all instructions in this manual can result in personal injury or death.**

**All electric work must be performed by a licensed electrician and conform to local building codes or, in the absence of local codes, with the National Electrical Code, and the instructions given in this manual. If the power source capacity is inadequate or the electric work is not performed properly, it will result in fire, electric shock, physical injury or death.**

**Refer to local, state, and federal codes, and use power wires of sufficient current capacity and rating. Wires that are too small will generate heat and cause a fire.**

**Secure all field wiring connections with appropriate wire strain relief. Improperly securing wires will create undue stress on equipment power lugs. Inadequate connections will generate heat, cause a fire and physical injury or death.**

**Ensure the system is connected to a dedicated power source that provides adequate power. If the power source capacity is inadequate or the electric work is not performed properly, it will result in fire, electric shock, physical injury or death.**

**Properly tighten all power connections. Loose wiring will overheat at connection points, causing a fire, physical injury or death.**

⊘ **Do not change the settings of the protection devices. If the protection devices have been bypassed or are forced to operate improperly, or parts other than those specified by LG are used, there is risk of fire, electric shock, explosion, and physical injury or death.**

## Note:

⊘ **Do not supply power to the unit until all electrical wiring, controls wiring, piping, installation, and refrigerant system evacuation are completed. System will malfunction.**

**The information contained in this manual is intended for use by an industry-qualified, experienced, certified electrician familiar with the U.S. National Electric Code (NEC) who is equipped with the proper tools and test instruments. Failure to carefully read and follow all instructions in this manual can result in equipment malfunction and / or property damage.**

## Operation

### **⚠ DANGER**

⊘ Do not provide power to or operate the unit if it is flooded or submerged.

*There is risk of fire, electric shock, physical injury or death.*

**Use a dedicated breaker for this product.**

*There is risk of fire, electric shock, physical injury or death.*

⊘ Do not operate the disconnect switch with wet hands.

*There is risk of fire, electric shock, physical injury or death.*

**Periodically verify the equipment mounts have not deteriorated.**

*If the base collapses, the unit could fall and cause physical injury or death.*

**Use inert (nitrogen) gas when performing leak tests or air purges. ⊘ Do not use compressed air, oxygen, or flammable gases.**

*Using these substances will cause fire, explosion, and physical injury or death.*

**If refrigerant leaks out, ventilate the area before operating the unit.**

*If the unit is mounted in an enclosed, low-lying, or poorly ventilated area, and the system develops a refrigerant leak, it will cause a fire, electric shock, explosion, physical injury or death.*

### **⚠ WARNING**

⊘ Do not allow water, dirt, or animals to enter the unit.

*There is risk of fire, electric shock, physical injury or death.*

⊘ Do not operate the unit with the panel(s) or protective cover(s) removed; keep fingers and clothing away from moving parts.

*The rotating, hot, cold, and high-voltage parts of the unit can cause physical injury or death.*

⊘ Do not touch the refrigerant piping during or after operation.

*It can cause burns or frostbite.*

⊘ Do not open the inlet during operation.

*There is risk of electric shock, physical injury or death.*

### **⚠ CAUTION**

**To avoid physical injury, use caution when cleaning or servicing the air conditioner.**

*There is risk of electric shock, physical injury or death.*

## Note:

**Clean up the site after servicing is finished, and check that no metal scraps, screws, or bits of wiring have been left inside or surrounding the unit.**

⊘ Do not use the product for mission critical or special purpose applications such as preserving foods, works of art, or other precision air conditioning applications. The equipment is designed to provide comfort cooling and heating.

*Oil, steam, sulfuric smoke, etc., can significantly reduce the performance of the unit, or damage its parts.*

⊘ Do not block the inlet or outlet.

*Unit will malfunction.*

⊘ Do not allow water, dirt, or animals to enter the unit.

*There is risk of unit failure.*

⊘ Do not open the inlet during operation.

*There is risk of unit failure.*

⊘ Do not operate the unit when the panel(s) or protective cover(s) are removed.

*Non-secured covers can result in product malfunction due to dust or water in the service panel.*

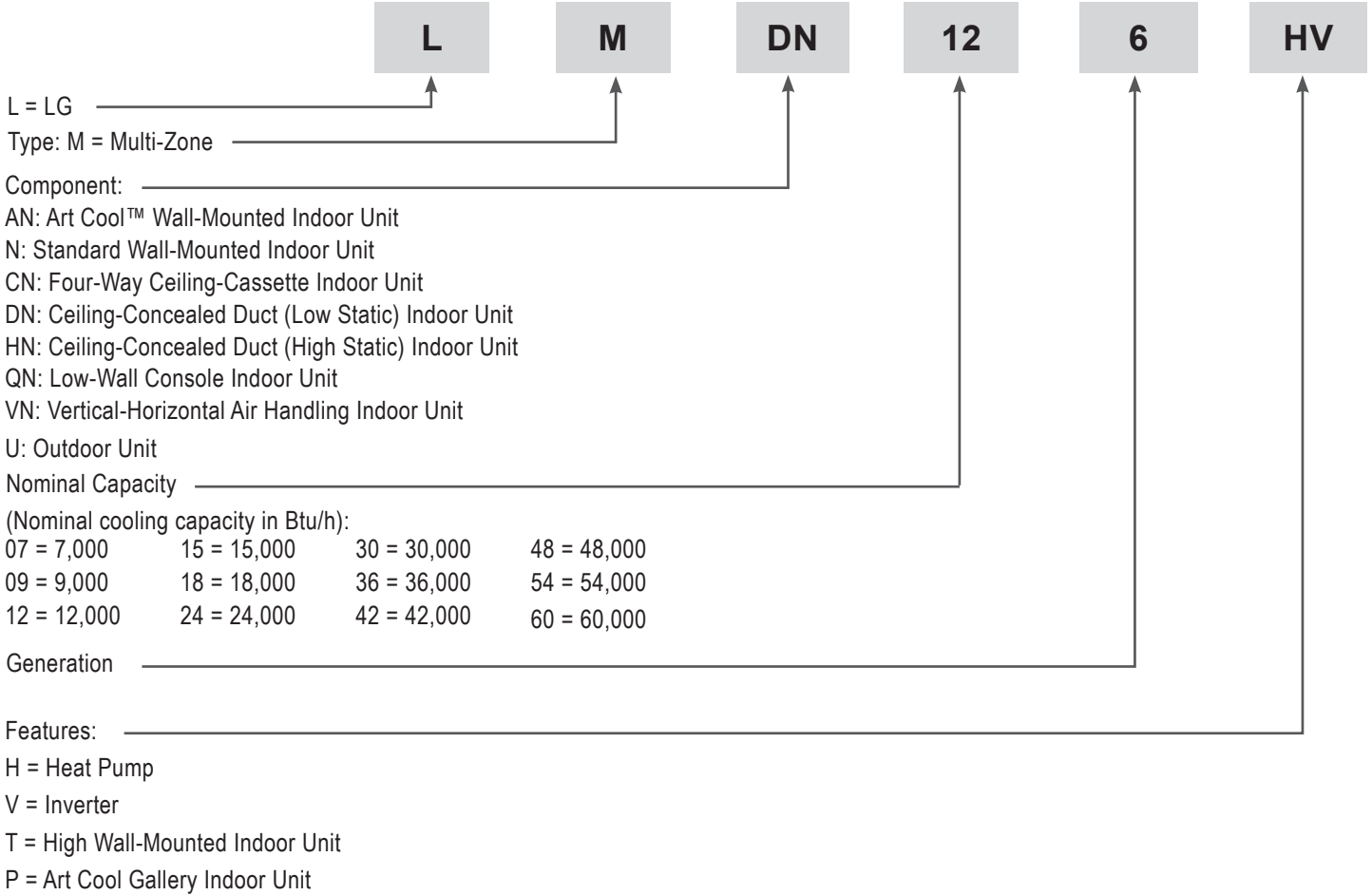
**Periodically verify the equipment mounts have not deteriorated.**

*If the base collapses, the unit could fall and cause property damage or product failure.*

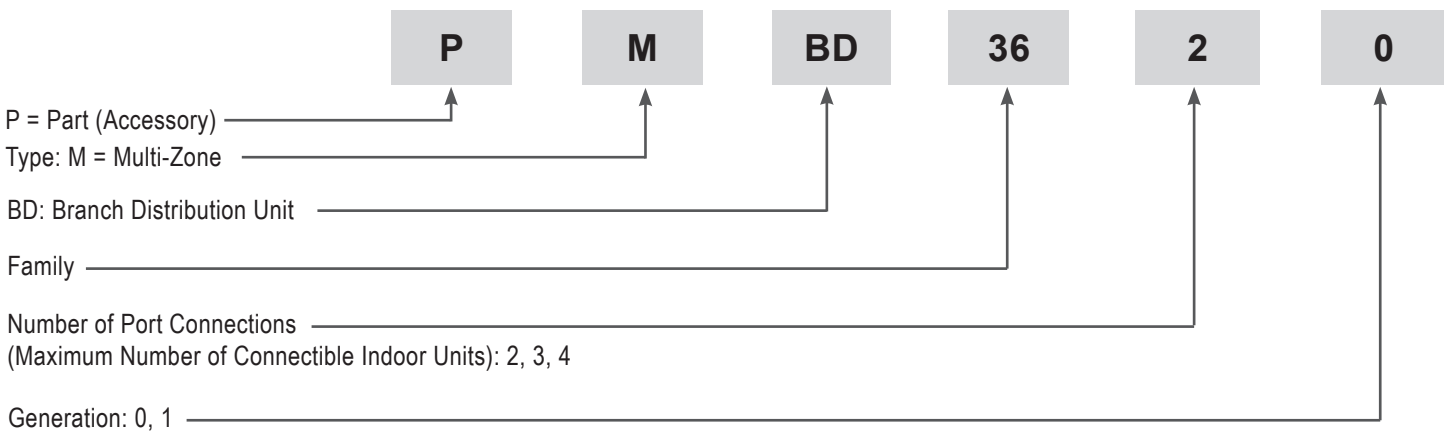
**Use a only soft cloth to clean the air conditioner. ⊘ Do not use wax, thinner, or strong detergents.**

*Strong cleaning products will damage the surface of the air conditioner, or will cause its appearance to deteriorate.*

## Multi-Zone Systems — Indoor Units and Outdoor Units



## Branch Distribution Units



### Note:

- Voltage for all equipment is 208-230V, 60 Hz, 1-phase.
- All indoor units are compatible with wired controllers.
- All outdoor units are LGAP control network compatible with PI-485 V-net Control Integration Board (PMNFP14A1, sold separately).
- Compatible single zone IDU nomenclature is listed in the Single Zone Wall-Mounted IDU Engineering Manual.

Table 1: Multi F Outdoor Unit Specifications.

Model Number	LMU180HV	LMU18CHV	LMU240HV	LMU24CHV
<b>Cooling Capacity (Btu/h)<sup>1</sup> (Min.~Rated~ Max.)</b>	8,400~18,000~21,600	8,400~17,000~19,000	8,400~23,600~25,000	8,400~20,000~25,000
<b>Heating Capacity (Btu/h)<sup>1</sup> (Min.~Rated~ Max.)</b>	10,080~22,000~25,000	10,248~22,000~24,000	10,080~24,600~29,000	9,240~24,000~28,800
<b>Operating Range</b>				
<b>Cooling (°F DB)</b>	14 <sup>7</sup> to 118	14 <sup>7</sup> to 118	14 <sup>7</sup> to 118	14 <sup>7</sup> to 118
<b>Heating (°F WB)</b>	-4 to +64	-4 to +64	-4 to +64	-4 to +64
<b>Compressor</b>				
<b>Inverter Quantity</b>	Twin Rotary x 1	Twin Rotary x 1	Twin Rotary x 1	Twin Rotary x 1
<b>Oil/Type</b>	FVC68D	FVC68D	FVC68D	FVC68D
<b>Fan (Side Discharge)</b>				
<b>Type</b>	Propeller	Propeller	Propeller	Propeller
<b>Motor Output (W) x Qty.</b>	85.4 x 1	85.4 x 1	85.4 x 1	85.4 x 1
<b>Motor / Drive</b>	Brushless Digitally Controlled / Direct			
<b>Maximum Air Volume (CFM)</b>	1,766	1,766	1,766	1,766
<b>Unit Data</b>				
<b>Refrigerant Type</b>	R410A	R410A	R410A	R410A
<b>Refrigerant Control/Location</b>	EEV / Outdoor Unit	EEV / Outdoor Unit	EEV / Outdoor Unit	EEV / Outdoor Unit
<b>Min. Number Indoor Units / System<sup>2</sup></b>	2	2	2	2
<b>Max. Number Indoor Units / System<sup>2</sup></b>	2	2	3	3
<b>Maximum Allowable Total Indoor Unit Connected Capacity (Btu/h)</b>	24,000	24,000	33,000	33,000
<b>Sound Pressure (Cooling / Heating) dB(A)<sup>3</sup></b>	49 / 54	49 / 52	50 / 54	49 / 52
<b>Net Unit Weight (lbs.)</b>	101	100	101.4	100
<b>Shipping Weight (lbs.)</b>	109.8	108	110.2	108
<b>Power Wiring / Comm. Cable (No. x AWG)<sup>4,5</sup></b>	4C x 14	4C x 14	4C x 14	4C x 14
<b>Heat Exchanger</b>				
<b>Material and Fin Coating</b>	Copper Tube/Aluminum Fin and GoldFin™/Hydrophilic			
<b>Rows / Columns/Fins per inch x Qty.</b>	(2 x 28 x 14) x 1	(2 x 28 x 14) x 1	(2 x 28 x 14) x 1	(2 x 28 x 14) x 1
<b>Piping</b>				
<b>Liquid Line Connection (in., OD) x Qty.</b>	1/4 x 2	1/4 x 2	1/4 x 3	1/4 x 3
<b>Vapor Line Connection (in., OD) x Qty.</b>	3/8 x 2	3/8 x 2	3/8 x 3	3/8 x 3
<b>Factory Charge lbs. of R410A</b>	3.97	3.96	3.97	3.96
<b>Piping Lengths</b>				
<b>Maximum Total Piping (ft.)<sup>6</sup></b>	164.0	164.0	230.0	246.1
<b>Max. Outdoor Unit to Indoor Unit Piping (ft)</b>	82.0	82.0	82.0	82.0
<b>Piping Length (No Additional Refrigerant [ft])</b>	98.4	49.2	98.4	73.8
<b>Max. Elevation between Outdoor Unit and Indoor Unit (ft.)</b>	49.2	49.2	49.2	49.2
<b>Max. Elevation between Indoor Unit and Indoor Unit (ft.)</b>	24.6	24.6	24.6	24.6

<sup>1</sup>Rated capacity applied with non-ducted indoor units, and is rated 0 ft. above sea level with 25 ft. of refrigerant line per indoor unit and a 0 ft. level difference between outdoor and indoor units. All capacities are net with a combination ratio between 95 – 105%.

Rated cooling capacity obtained with air entering the indoor unit at 80°F dry bulb (DB) and 67°F wet bulb (WB) and outdoor ambient conditions of 95°F dry bulb (DB) and 75°F wet bulb (WB).

Rated heating capacity obtained with air entering the indoor unit at 70°F dry bulb (DB) and 60°F wet bulb (WB) and outdoor ambient conditions of 47°F dry bulb (DB) and 43°F wet bulb (WB).

<sup>2</sup>At least two indoor units must be connected. For allocated capacity information, see the combination tables in the "Multi F / Multi F MAX Combination Data Manual" on www.lghvac.com. For performance data, see "Multi F / Multi F MAX Performance Data Manual" on www.lghvac.com.

<sup>3</sup>Sound pressure levels are tested in an anechoic chamber under ISO Standard 3745 and

are the same in both cooling and heating mode. These values can increase due to ambient conditions during operation.

<sup>4</sup>Power wiring to the outdoor unit is field supplied, solid or stranded, and must comply with the applicable local and national codes. For detailed information, please refer to electrical characteristics on page 11.

<sup>5</sup>Power wiring / communication cable to be minimum 14 AWG, 4-conductor from the outdoor unit to the indoor unit, stranded, shielded or unshielded (if shielded, it must be grounded to the chassis of the outdoor unit only), and must comply with applicable local and national codes. For detailed electrical information, please refer to electric characteristics on page 11.

<sup>6</sup>Piping lengths are equivalent.

<sup>7</sup>Installation of an optional Low Ambient Wind Baffle Kit will allow operation down to -4°F in cooling mode.

# GENERAL DATA

## Multi F Outdoor Unit Specifications

**MULTI F**  
**MULTI F MAX**

Table 2: Multi F Outdoor Unit Specifications.

Model Number	LMU30CHV	LMU36CHV
Cooling Capacity (Btu/h) <sup>1</sup> (Min.~Rated~ Max.)	8,400~30,000~36,000	8,400~32,000~38,400
Heating Capacity (Btu/h) <sup>1</sup> (Min.~Rated~ Max.)	9,240~32,000~38,400	9,240~36,000~41,600
<b>Operating Range</b>		
Cooling (°F DB)	14 <sup>7</sup> to 118	14 <sup>7</sup> to 118
Heating (°F WB)	-4 to +64	-4 to +64
<b>Compressor</b>		
Inverter Quantity	Twin Rotary x 1	Twin Rotary x 1
Oil / Type	FVC68D	FVC68D
<b>Fan (Side Discharge)</b>		
Type	Propeller	Propeller
Motor Output (W) x Qty.	124.2 x 1	124.2 x 1
Motor / Drive	Brushless Digitally Controlled / Direct	
Maximum Air Volume (CFM)	2,119	2,119
<b>Unit Data</b>		
Refrigerant Type	R410A	R410A
Refrigerant Control/Location	EEV/Outdoor Unit	EEV/Outdoor Unit
Min. Number Indoor Units / System <sup>2</sup>	2	2
Max. Number Indoor Units / System <sup>2</sup>	4	4
Maximum Allowable Total Indoor Unit Connected Capacity (Btu/h)	40,000	48,000
Sound Pressure (Cooling / Heating) dB(A) <sup>3</sup>	52 / 55	52 / 55
Net Unit Weight (lbs.)	137	137
Shipping Weight (lbs.)	148	148
Power Wiring / Communications Cable (No. x AWG) <sup>4,5</sup>	4C x 14	4C x 14
<b>Heat Exchanger</b>		
Material and Fin Coating	Copper Tube/Aluminum Fin and GoldFin™/Hydrophilic	
Rows/Columns / Fins per inch x Qty.	(2 x 38 x 14) x 1	(2 x 38 x 14) x 1
<b>Piping</b>		
Liquid Line Connection (in., OD) x Qty.	1/4 x 4	1/4 x 4
Vapor Line Connection (in., OD) x Qty.	3/8 x 4	3/8 x 4
Factory Charge lbs. of R410A	6.18	6.18
<b>Piping Lengths</b>		
Maximum Total Piping (ft.) <sup>6</sup>	246.1	246.1
Maximum Outdoor Unit to Indoor Unit Piping (ft.)	82.0	82.0
Piping Length (No Additional Refrigerant [ft])	98.4	98.4
Maximum Elevation between Outdoor Unit and Indoor Unit (ft.)	49.2	49.2
Maximum Elevation between Indoor Unit and Indoor Unit (ft.)	24.6	24.6

<sup>1</sup>Rated capacity applied with non-ducted indoor units, and is rated 0 ft. above sea level with 25 ft. of refrigerant line per indoor unit and a 0 ft. level difference between outdoor and indoor units. All capacities are net with a combination ratio between 95 – 105%.

Rated cooling capacity obtained with air entering the indoor unit at 80°F dry bulb (DB) and 67°F wet bulb (WB) and outdoor ambient conditions of 95°F dry bulb (DB) and 75°F wet bulb (WB).

Rated heating capacity obtained with air entering the indoor unit at 70°F dry bulb (DB) and 60°F wet bulb (WB) and outdoor ambient conditions of 47°F dry bulb (DB) and 43°F wet bulb (WB).

<sup>2</sup>At least two indoor units must be connected. For allocated capacity information, see the combination tables in the "Multi F / Multi F MAX Combination Data Manual" on www.lghvac.com. For performance data, see "Multi F / Multi F MAX Performance Data Manual" on www.lghvac.com.

<sup>3</sup>Sound pressure levels are tested in an anechoic chamber under ISO Standard 3745 and

are the same in both cooling and heating mode. These values can increase due to ambient conditions during operation.

<sup>4</sup>Power wiring to the outdoor unit is field supplied, solid or stranded, and must comply with the applicable local and national codes. For detailed information, please refer to electrical characteristics on page 11.

<sup>5</sup>Power wiring / communication cable to be minimum 14 AWG, 4-conductor from the outdoor unit to the indoor unit, stranded, shielded or unshielded (if shielded, it must be grounded to the chassis of the outdoor unit only), and must comply with applicable local and national codes. For detailed electrical information, please refer to electric characteristics on page 11.

<sup>6</sup>Piping lengths are equivalent.

<sup>7</sup>Installation of an optional Low Ambient Wind Baffle Kit will allow operation down to -4°F in cooling mode.



Table 3: Multi F Outdoor Unit Electrical Data.

Nominal Tons	Unit Model No.	Hertz	Voltage	Voltage Range (Min. to Max.)	MCA	MOP	Compressor Quantity	Compressor Motor RLA	Outdoor Fan Motor		Indoor Fan Motor
									kW	FLA	FLA
1.5	LMU180HV	60	208 - 230	187 - 253	15.8	20	1	12.0	0.085	0.40	0.40
1.5	LMU18CHV				13.3	20	1	8.9	0.09	0.59	1.60
2	LMU240HV				16.0	20	1	12.0	0.085	0.40	0.60
2	LMU24CHV				14.3	20	1	9.4	0.09	0.59	2.00
2.5	LMU30CHV				16.6	25	1	10.8	0.12	0.73	2.40
3	LMU36CHV				17.9	25	1	11.2	0.12	0.73	3.20

Voltage tolerance is ±10%.

Maximum allowable voltage unbalance is 2%.

RLA = Rated Load Amps.

MCA = Minimum Circuit Ampacity.

Maximum Overcurrent Protection (MOP) is calculated as follows:  
(Largest motor FLA x 2.25) + (Sum of other motor FLA) rounded down to the nearest standard fuse size.

Indoor Fan Motor (FLA) is based on the maximum combination of indoor units.

The max combination for each outdoor unit is:

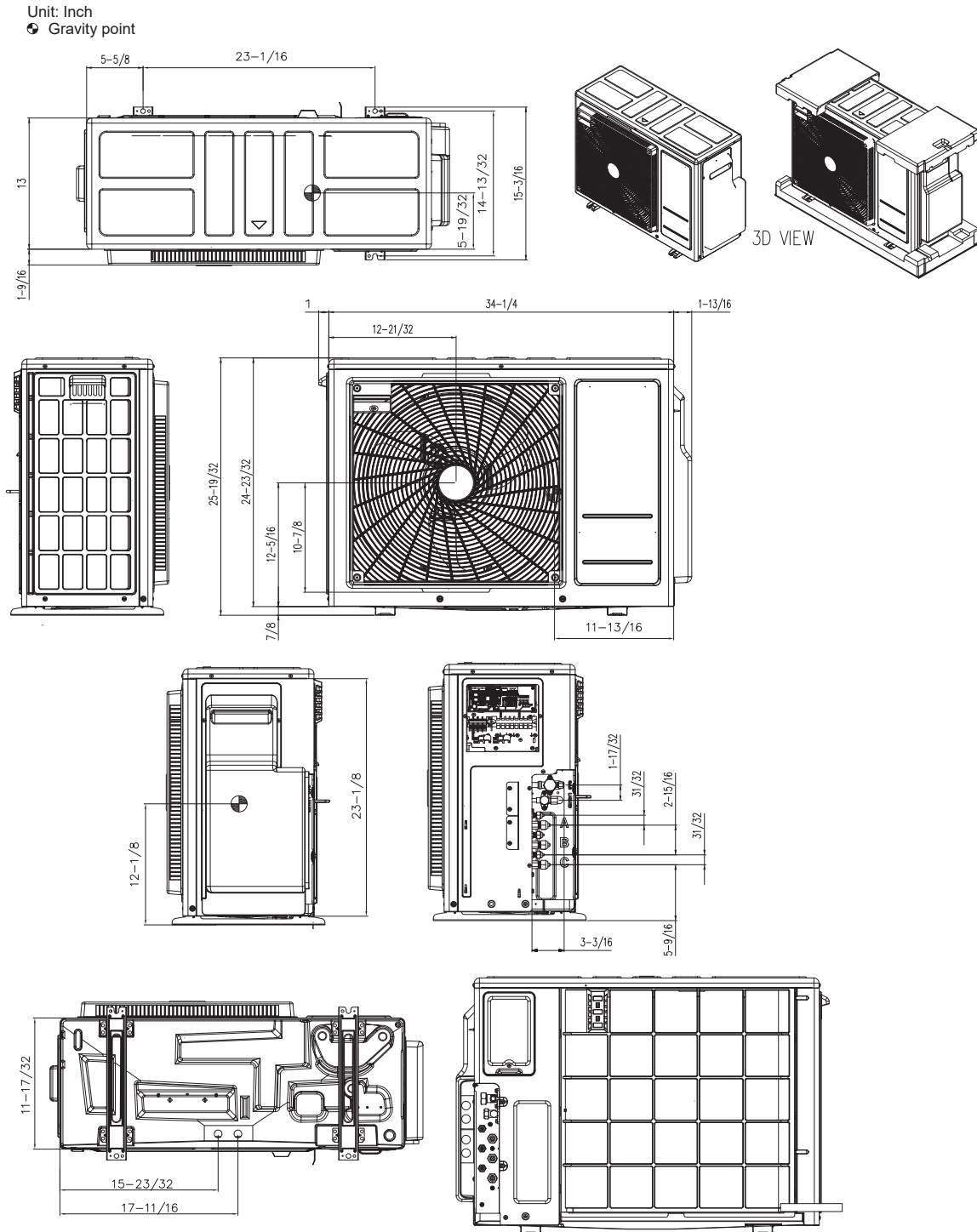
- 18,000 ODU (LMU180HV / LMU18CHV): 12,000 IDU x 2
- 24,000 ODU (LMU240HV / LMU24CHV): 12,000 IDU x 2 + 9,000 IDU x 1
- 30,000 ODU (LMU30CHV): 12,000 IDU x 3
- 36,000 ODU (LMU36CHV): 12,000 IDU x 4

# GENERAL DATA

## Multi F Outdoor Unit Dimensions

MULTI F  
MULTI F MAX

Figure 1: LMU180HV and LMU240HV Multi F Outdoor Unit External Dimensions.



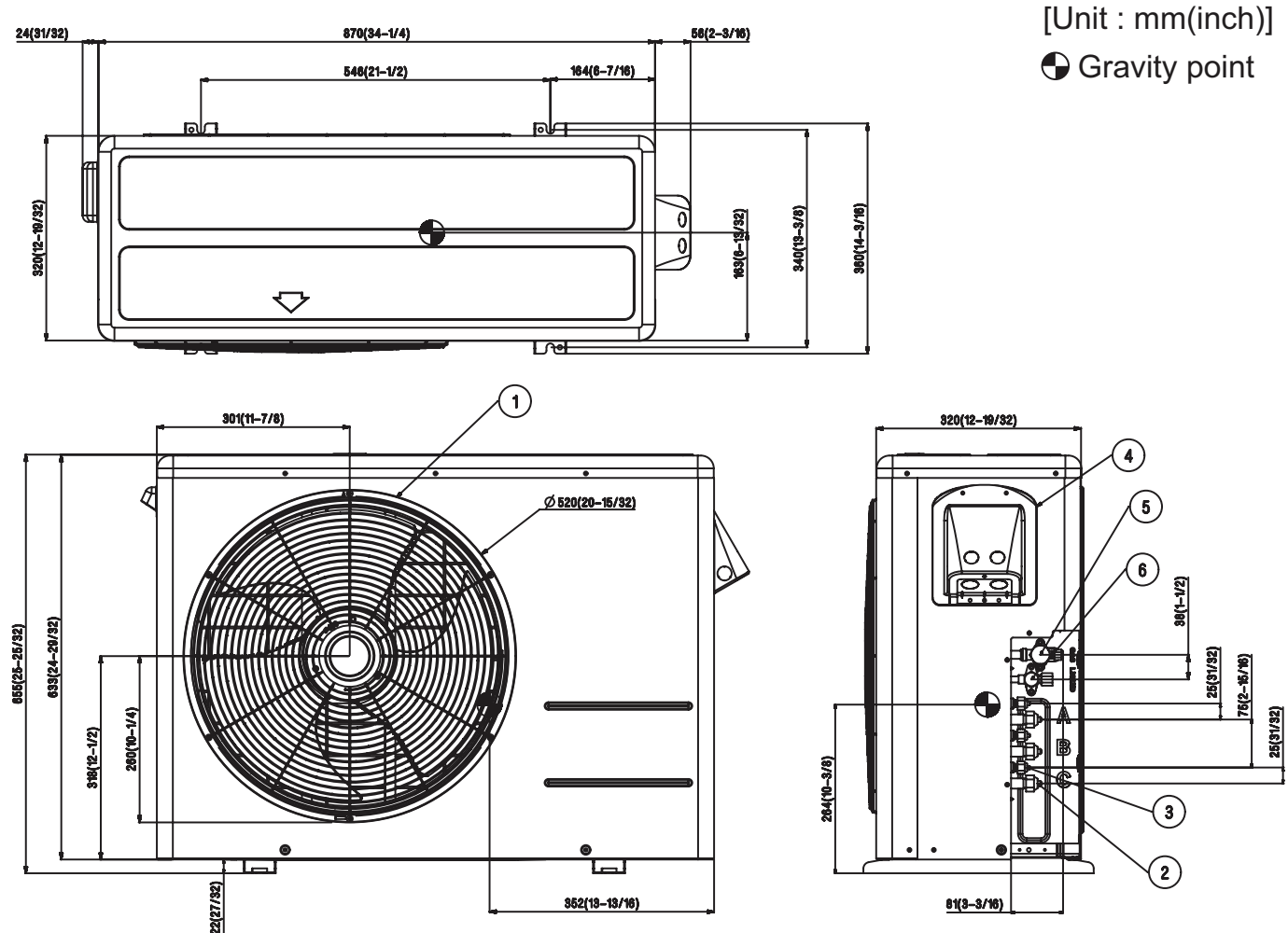
(BACK)

**Notes:**

1. Unit must be installed in compliance with the installation manual.
2. Unit must be grounded in accordance with the local or state regulations and applicable national codes.
3. All field-supplied electrical components and materials must comply with the local, state, and national codes.
4. Electrical characteristics must be considered for electrical work and design. The capacity of power cable and circuit breaker for the outdoor unit must follow local, state, national, and manufacturer requirements.
5. For LMU180HV Unit, ports A and B are available.
6. For LMU240HV Unit, ports A, B, and C are available.



Figure 2: LMU18CHV and LMU24CHV Multi F Outdoor Unit External Dimensions.



**Notes:**

No.	Part Name
1	Air discharge grille
2	Vapor pipe connection
3	Liquid pipe connection
4	Power & transmission connection
5	Main service valve (Vapor)
6	Main service valve (Liquid)

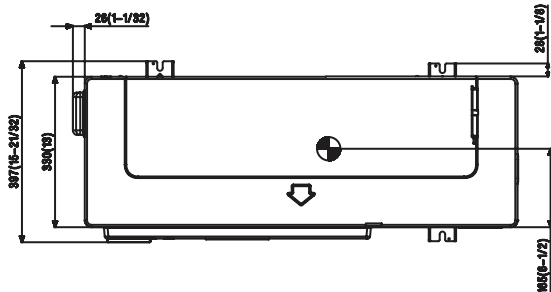
- Unit must be installed in compliance with the installation manual.
- Unit must be grounded in accordance with the local or state regulations and applicable national codes.
- All field-supplied electrical components and materials must comply with the local, state, and national codes.
- Electrical characteristics must be considered for electrical work and design. The capacity of power cable and circuit breaker for the outdoor unit must follow local, state, national, and manufacturer requirements.
- For LMU18CHV Unit, ports A and B are available.
- For LMU24CHV Unit, ports A, B, and C are available.

# GENERAL DATA

## Multi F Outdoor Unit Dimensions

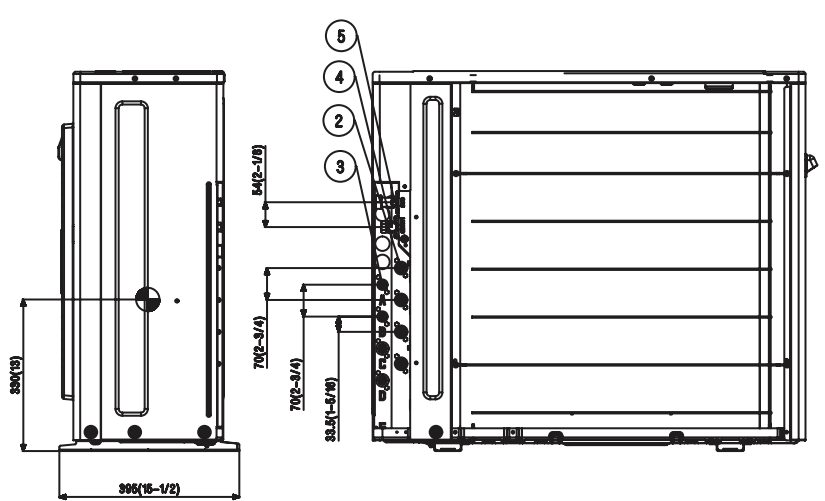
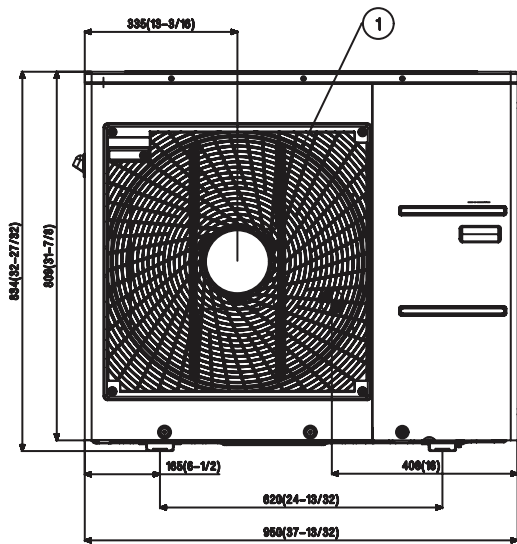
MULTI F  
MULTI F MAX

Figure 3: LMU30CHV and LMU36CHV Multi F Outdoor Unit External Dimensions.



[Unit : mm(inch)]

⊕ Gravity point



No.	Part Name
1	Air discharge grille
2	Vapor pipe connection
3	Liquid pipe connection
4	Main service valve (Liquid)
5	Main service valve (Vapor)

### Notes:

- Unit must be installed in compliance with the installation manual.
- Unit must be grounded in accordance with the local or state regulations and applicable national codes.
- All field-supplied electrical components and materials must comply with local, state, and national codes.
- Electrical characteristics must be considered for electrical work and design. The capacity of power cable and circuit breaker for the outdoor unit must follow local, state, national, and manufacturer requirements.

Table 4: Multi F MAX Outdoor Unit General Data.

Model Number	LMU480HV	LMU540HV	LMU600HV
Cooling Capacity (Btu/h) (Minimum ~ Rated ~ Maximum) <sup>1</sup>	14,400~48,000~58,000	14,400~52,500~63,200	15,600~60,000~68,000
Heating Capacity (Btu/h) (Minimum ~ Rated ~ Maximum) <sup>1</sup>	15,840~54,000~61,000	16,272~58,000~64,000	17,940~64,000~70,000
<b>Operating Range</b>			
Cooling (°F DB)	14 <sup>7</sup> - 118	14 <sup>7</sup> - 118	14 <sup>7</sup> - 118
Heating (°F WB)	-4 - 64	-4 - 64	-4 - 64
<b>Compressor</b>			
Inverter Quantity	Twin Rotary x 1	Twin Rotary x 1	Twin Rotary x 1
Oil Type	FVC68D	FVC68D	FVC68D
<b>Fan (Side Discharge)</b>			
Type	Propeller	Propeller	Propeller
Motor Output (W) x Qty.	124.2 x 2	124.2 x 2	124.2 x 2
Motor/Drive	Brushless Digitally Controlled/Direct		
Maximum Air Volume (CFM)	2,119 x 2	2,119 x 2	2,119 x 2
<b>Unit Data</b>			
Refrigerant Type	R410A	R410A	R410A
Refrigerant Control/Location	EEV / Outdoor Unit, Branch Distribution Unit		
Min. Number Indoor Units/System <sup>2</sup>	2	2	2
Max. Number Indoor Units/System <sup>2</sup>	8	8	8
Maximum Allowable Total Indoor Unit Connected Capacity (Btu/h)	65,000	73,000	81,000
Sound Pressure ±3 dB(A) <sup>3</sup> (Cooling / Heating)	54 / 56	54 / 56	56 / 58
Net Unit Weight (lbs.)	214	214	223
Shipping Weight (lbs.)	236	236	249
Power/Communications Wiring Between ODU and BD Unit (No. X AWG) <sup>4,5</sup>	4C X 14	4C X 14	4C x 14
<b>Heat Exchanger</b>			
Material and Fin Coating	Copper Tube / Aluminum Fin and GoldFin™/Hydrophilic		
Rows/Columns/Fins per inch x Qty.	(2 x 32 x 14) x 2	(2 x 32 x 14) x 2	(3 x 32 x 14) x 2
<b>Piping</b>			
Liquid Line Connection (in., OD) x Qty.	3/8 x 1	3/8 x 1	3/8 x 1
Vapor Line Connection (in., OD) x Qty.	3/4 x 1	3/4 x 1	3/4 x 1
Factory Charge lbs. of R410A	9.7	9.7	12.3
<b>Piping Lengths</b>			
Maximum Total System Piping (ft.) <sup>6</sup>	475.7	475.7	475.7
Maximum Main Pipe Length (Outdoor Unit to BD Unit [ft.])	180.4	180.4	180.4
Total Branch Piping (BD Units to all Indoor Units [ft.])	295.3	295.3	295.3
Maximum Branch Pipe Length (Length between each BDU and IDU [ft.])	49.2	49.2	49.2
Maximum Outdoor Unit to Indoor Unit Pipe Length (ft.)	229.6	229.6	229.6
Max. Main Piping Length (No Additional Refrigerant (ft.))	16	16	16
Max. Branch Piping Length (No Additional Refrigerant (ft.))	131	131	147.6
Maximum Elevation between Outdoor Unit and Indoor Unit (ft.)	98.4	98.4	98.4
Maximum Elevation between Indoor Unit and Indoor Unit (ft.)	49.2	49.2	49.2
Maximum Elevation between BD Unit and Indoor Unit (ft.)	32.8	32.8	32.8
Maximum Elevation between BD Unit and BD Unit (ft.)	49.2	49.2	49.2

<sup>1</sup>Rated capacity applied with non-ducted indoor units, and is rated 0 ft. above sea level with a 0 ft. level difference between outdoor and indoor units. All capacities are net with a combination ratio between 95 – 105%.

Rated cooling capacity obtained with air entering the indoor unit at 80°F dry bulb (DB) and 67°F wet bulb (WB) and outdoor ambient conditions of 95°F dry bulb (DB) and 75°F wet bulb (WB). Rated heating capacity obtained with air entering the indoor unit at 70°F dry bulb (DB) and 60°F wet bulb (WB) and outdoor ambient conditions of 47°F dry bulb (DB) and 43°F wet bulb (WB).

<sup>2</sup>At least one Branch Distribution Unit is required for system operation; a maximum of two can be installed per outdoor unit with use of Y-branch accessory (PMBL5620). At least two indoor units must be connected. For allocated capacity information, see the combination tables in the "Multi F / Multi F MAX Combination Data Manual" on www.lghvac.com. For performance data, see "Multi F / Multi F MAX Performance Data Manual" on www.lghvac.com.

<sup>3</sup>Sound pressure levels are tested in an anechoic chamber under ISO Standard 3745. These values can increase due to ambient conditions during operation.

<sup>4</sup>Power wiring to the outdoor unit is field supplied, solid or stranded, and must comply with the applicable local and national codes. For detailed information, please refer to electrical characteristics on page 16.

<sup>5</sup>Power wiring / communication cable to be minimum 14 AWG, 4-conductor from the outdoor unit to the BD unit (Multi F MAX systems only), and 14 AWG, 4-conductor from the BD unit to the indoor unit, stranded, shielded or unshielded (if shielded, it must be grounded to the chassis of the outdoor unit only), and must comply with applicable local and national codes. For detailed electrical information, please refer to electric characteristics on page 16.

<sup>6</sup>Piping lengths are equivalent.

<sup>7</sup>Installation of an optional Low Ambient Wind Baffle Kit will allow operation down to -4°F in cooling mode.

# GENERAL DATA

## Multi F MAX Outdoor Unit Electrical Data

MULTI F  
MULTI F MAX

Table 5: Multi F MAX Electrical Data.

Nominal Tons	Unit Model No.	Hertz	Voltage	Phase	Voltage Range (Min. to Max.)	MCA	MOP	Compressor Quantity	Compressor Motor RLA	Condenser Fan Motor(s)		Indoor Fan Motor
										Condenser Fan Quantity x kW	Condenser Fan Motor FLA	
4.0	LMU480HV	60	208 - 230	1	187 - 253	27.3	40	1	17.5	2 x 0.12	0.73 x 2	4.0
4.5	LMU540HV	60	208 - 230		187 - 253	29.4	40	1	18.5	2 x 0.12	0.73 x 2	4.8
5.0	LMU600HV	60	208 - 230		187 - 253	32.2	45	1	20.4	2 x 0.12	0.73 x 2	5.2

Voltage tolerance is  $\pm 10\%$ .

Maximum allowable voltage unbalance is 2%.

RLA = Rated Load Amps.

MCA = Minimum Circuit Ampacity.

Maximum Overcurrent Protection (MOP) is calculated as follows: (Largest motor FLA x 2.25) + (Sum of other motor FLA) rounded down to the nearest standard fuse size.

Indoor Fan Motor (FLA) is based on the maximum combination of indoor units.

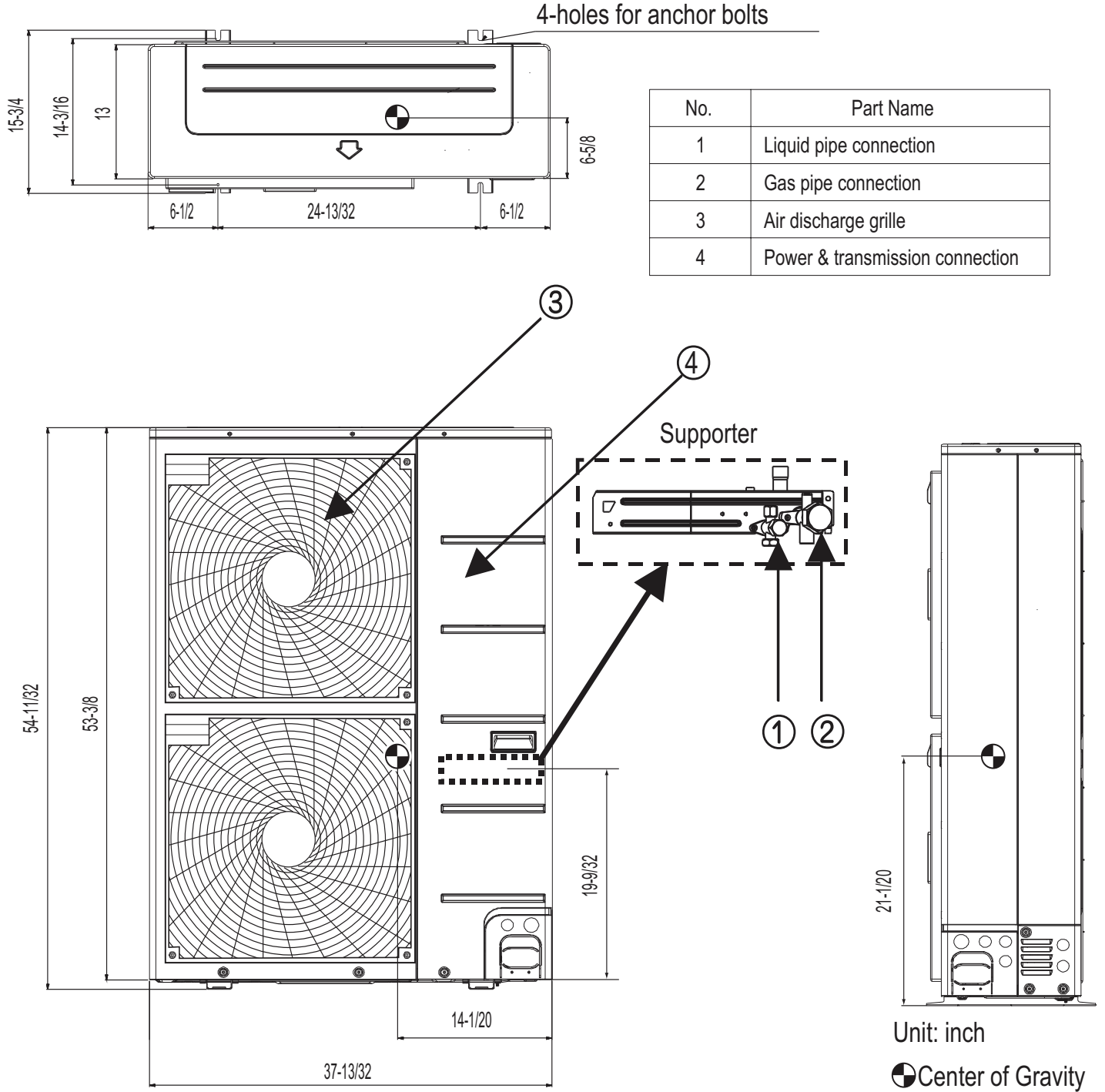
The max combination for each outdoor unit is:

- 48,000 ODU (LMU480HV): 12,000 IDU x 5

- 54,000 ODU (LMU540HV): 12,000 IDU x 6

- 60,000 ODU (LMU600HV): 12,000 IDU x 6 + 9,000 IDU x 1

Figure 4: LMU480HV, LMU540HV, and LMU600HV Multi F MAX Outdoor Unit External Dimensions.



# GENERAL DATA

MULTI F  
MULTI F MAX

## Branch Distribution Unit Specification / Electrical Data

Table 6: Branch Distribution Unit General Data.

Model Number	PMBD3620	PMBD3630	PMBD3640	PMBD3641	
No. of Connectible Indoor Units <sup>1</sup>	1-2	1-3	1-4	1-4	
Max. Nominal Capacity / Port (Btu/h) <sup>2</sup>	24,000	24,000	24,000	Ports A, B, C: 24,000; Port D: 36,000	
Connected Indoor Unit Capacity	7,000 ~ 24,000	7,000 ~ 24,000	7,000 ~ 24,000	Ports A, B, C: 7,000 ~ 24,000; Port D: 24,000 or 36,000	
Max. Nominal Capacity / Branch Distribution Unit (Btu/h)	48,000	72,000	73,000	73,000	
Operation Temperature Range (°F DB)	0 ~ 150	0 ~ 150	0 ~ 150	0 ~ 150	
Maximum Humidity	80%	80%	80%	80%	
<b>Unit Data</b>					
Refrigerant Type	R410A	R410A	R410A	R410A	
Power Supply V, Ø, Hz	208-230, 1, 60	208-230, 1, 60	208-230, 1, 60	208-230, 1, 60	
Power Input (W)	16	24	32	32	
Rated Amps (A)	0.08	0.12	0.16	0.16	
Dimensions W x H x D (in.)	17-3/32 x 6-13/32 x 10-23/32	17-3/32 x 6-13/32 x 10-23/32	17-3/32 x 6-13/32 x 10-23/32	17-3/32 x 6-13/32 x 10-23/32	
Net Unit Weight (lbs.)	13	14.3	15.7	15.7	
Shipping Weight (lbs.)	15	17	18	18	
<b>Communication / Connection (Power) Cables<sup>3</sup></b>					
From Outdoor Unit to Branch Distribution Unit (Qty. x AWG) <sup>3</sup>	4C x 14	4C x 14	4C x 14	4C x 14	
From Branch Distribution Unit to Indoor Unit (Qty. x AWG) <sup>3</sup>	4C x 14	4C x 14	4C x 14	4C x 14	
<b>Piping Connections</b>					
Outdoor Unit to Branch Distribution Unit	Liquid (in., OD)	Ø3/8	Ø3/8	Ø3/8	Ø3/8
	Vapor (in., OD)	Ø3/4	Ø3/4	Ø3/4	Ø3/4
Branch Distribution Unit to Indoor Units	Liquid (in., OD) x Qty.	Ø1/4 x 2	Ø1/4 x 3	Ø1/4 x 4	Ø1/4 x 4
	Vapor (in., OD) x Qty.	Ø3/8 x 2	Ø3/8 x 3	Ø3/8 x 4	Ø3/8 x 3; Ø1/2 x 1
<b>Piping Lengths</b>					
Maximum Total System Piping (ft.) <sup>4</sup>	475.7	475.7	475.7	475.7	
Maximum Main Pipe Length (Outdoor Unit to Branch Distribution Units [ft.])	180.4	180.4	180.4	180.4	
Total Branch Piping (Branch Distribution Units to Indoor Units [ft.])	295.3	295.3	295.3	295.3	
Maximum Branch Pipe Length Between Branch Distribution Unit and Each Indoor Unit [ft.]	49.2	49.2	49.2	49.2	
Maximum Outdoor Unit to Indoor Unit Pipe Length (ft.)	229.6	229.6	229.6	229.6	
Piping Length (No Additional Refrigerant [ft.]; approx. 16 ft. of Main Piping + 131 ft. of Branch Piping)	147.6	147.6	147.6	147.6	
Maximum Elevation between Branch Distribution Unit and Indoor Unit (ft.)	32.8	32.8	32.8	32.8	
Maximum Elevation between Branch Distribution Unit and Branch Distribution Unit (ft.)	49.2	49.2	49.2	49.2	

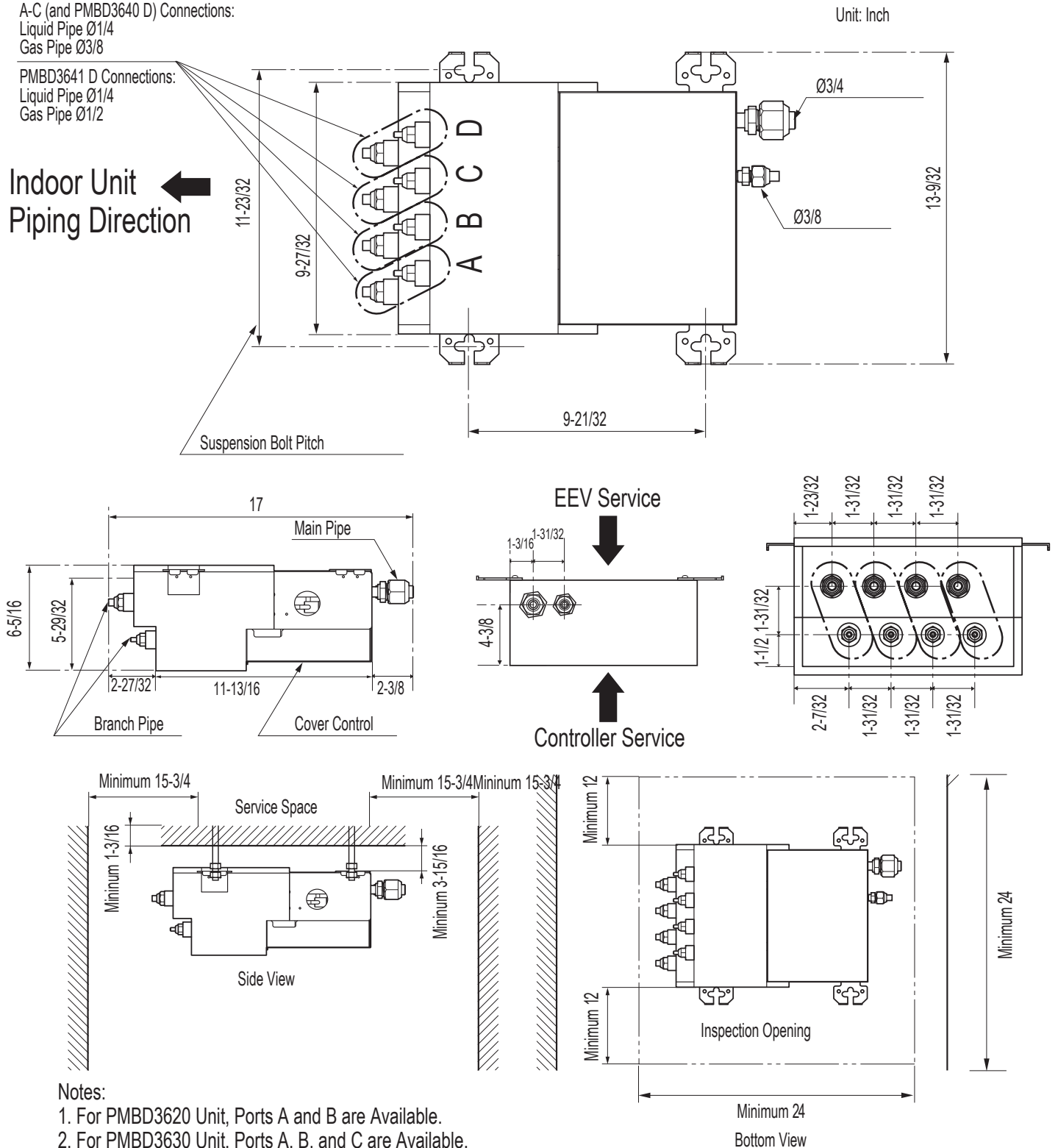
<sup>1</sup>At least one branch distribution Unit is required for system operation; a maximum of two can be installed per outdoor unit with use of Y-branch accessory (PMBL5620) To connect only one (1) indoor unit to a branch distribution unit, the system must include another branch distribution unit with at least one (1) connected indoor unit.

<sup>2</sup>Branch distribution Unit can accommodate from one (1) indoor unit up to four (4) indoor units depending on the ports available on the branch distribution Unit.

<sup>3</sup>Communication / power (connection) cable must be a minimum of 14 AWG, 4-conductor from the outdoor unit to the branch distribution unit (Multi F MAX systems only), and 14 AWG, 4-conductor from the branch distribution unit to the indoor unit, stranded, shielded or unshielded (if shielded, it must be grounded to the chassis of the outdoor unit only), and must comply with applicable local and national codes.

<sup>4</sup>Piping lengths are equivalent.

Figure 5: PMBD3620, PMBD3630, PMBD3640, and PMBD3641 External Dimensions.







## Transporting / Lifting the Outdoor Unit

- At the time of delivery, the package must be checked for any damage (exterior and interior). Report any damage to the carrier claims agent immediately.
- When lifting the unit, use lifting straps and place properly around the unit.
- Always lift the unit using properly sized lifting straps rated to carry the unit weight.
- Ensure the straps are long enough to maintain a maximum of a 40° angle.

### **⚠ WARNING**

**Be very careful when transporting the product. There is a risk of the product falling and causing physical injury.**

- Use appropriate moving equipment to transport each frame; ensure the equipment is capable of supporting the weights listed above. If the equipment is not properly secured, it will result in an accident that causes physical injury or death.
- Wear protective gloves when handling equipment. Sharp edges will cause personal injury.
- Dispose the packing materials safely. Packing materials, such as nails and other metal or wooden parts, will cause puncture wounds or other injuries.
- Tear apart and throw away plastic packaging bags so that children will not play with them and risk suffocation and death.
- Use caution when using a forklift to transport an unpackaged unit. The forklift arms must pass through the openings at the bottom.  Do not drop the unit when carrying it with a forklift. There is a risk of the product falling and causing physical injury.
- Consider the unit's center of gravity before lifting. Hoist the unit with the center of gravity centered among the lifting straps. There is a risk of the product falling and causing physical injury.
- Some products include polypropylene bands around the unit for packaging.  Do not use polypropylene bands to lift the unit. There is a risk of the product falling and causing physical injury.
- Lift the outdoor unit from the base at specified locations. Support the outdoor unit at a minimum of four (4) points to avoid slippage from the rigging apparatus. There is a risk of the product falling and causing physical injury.
- If a crane is to suspend the outdoor unit, it is recommended that two (2) ropes at least twenty-three (23) feet in length be used.
- Pass the ropes under the unit. Pass the rope through the two (2) forklift slots each at the front and rear of the outdoor unit.
- To prevent damage to the outdoor unit, always lift the unit with the ropes attached at four (4) points at an angle of ≤40°.

### **Note:**

- Make sure the outdoor unit is in its original packaging to avoid damage during local transport.
- Handle the outdoor unit with care. Keep the outdoor unit upright to avoid damaging inside components.
- When lifting, always include padding to protect the outdoor unit from rope damage.




Table 7: Multi F / Multi F MAX Shipping and Net Weights.

Model No.	Capacity (ton)	Shipping Weight (lbs.)	Net Weight (lbs.)
LMU180HV	1.5	109.8	101
LMU18CHV	1.5	108	100
LMU240HV	2	110.2	101.4
LMU24CHV	2	108	100
LMU30CHV	2.5	148	137
LMU36CHV	3	148	137
LMU480HV	4	236	214
LMU540HV	4.5		
LMU600HV	5	249	223



### Selecting the Best Location for the Outdoor Unit

#### **⚠ DANGER**

-  Do not install the unit in an area where combustible gas will generate, flow, stagnate, or leak. These conditions can cause a fire, resulting in bodily injury or death.
-  Do not install the unit in a location where acidic solution and spray (sulfur) are often used as it can cause bodily injury or death.
-  Do not use the unit in environments where oil, steam, or sulfuric gas are present as it can cause bodily injury or death.

#### **⚠ CAUTION**

When deciding on a location to place the outdoor unit, be sure to choose an area where run-off from defrost will not accumulate and freeze on sidewalks or driveways, which will create unsafe conditions. Properly install and insulate any drain hoses to prevent the hose from freezing, cracking, leaking, and causing unsafe conditions from frozen condensate.


#### **⚠ WARNING**

Install a fence to prevent vermin from crawling into the unit or unauthorized individuals from accessing it. Vermin and unauthorized individuals will cause a fire, electric shock, physical injury or death. Follow the placement guidelines set forth in "Clearance Requirements".

#### **Note:**

Install a fence to prevent vermin from crawling into the unit or unauthorized individuals from accessing it. Vermin and unauthorized individuals will damage the unit. Follow the placement guidelines set forth in "Clearance Requirements".

Select a location for installing the outdoor unit that will meet the following conditions:

- Where there is enough strength to bear the weight of the unit.
- A location that allows for optimum air flow and is easily accessible for inspection, maintenance, and service.
- Where piping between the outdoor unit and indoor unit (and branch distribution unit[s], if Multi F MAX) is within allowable limits.
- Include space for drainage to ensure condensate flows properly out of the unit when it is in heating mode.  Avoid placing the outdoor unit in a low-lying area where water could accumulate.
- If the outdoor unit is installed in a highly humid environment (near an ocean, lake, etc.), ensure that the site is well-ventilated and has a lot of natural light (Example: Install on a rooftop).

#### **Do Not's**

- Where it will be subjected to direct thermal radiation from other heat sources, or an area that would expose the outdoor unit to heat or steam like discharge from boiler stacks, chimneys, steam relief ports, other air conditioning units, kitchen vents, plumbing vents, and other sources of extreme temperatures.
- Where high-frequency electrical noise / electromagnetic waves will affect operation.
- Where operating sound from the unit will disturb inhabitants of surrounding buildings.
- Where the unit will be exposed to direct, strong winds.
- Where the discharge of one outdoor unit will blow into the inlet side of an adjacent unit (when installing multiple outdoor units).

### Outdoor Unit Condensate Drain Piping

Outdoor unit requires condensate drain piping. Condensate drain pipe is constructed with materials approved by local code. See pages 23 to 25 for information in reference to outdoor unit placement.

### Planning for Snow and Ice

To ensure the outdoor unit operates properly, certain measures are required in locations where there is a possibility of heavy snowfall or severe windchill or cold:

1. Prepare for severe winter wind chills and heavy snowfall, even in areas of the country where these are unusual phenomena.
2. Position the outdoor unit so that its airflow fans are not buried by direct, heavy snowfall. If snow piles up and blocks the airflow, the system will malfunction.
3. Remove any snow that has accumulated four (4) inches or more on the top of the outdoor unit.
4. In climates that will experience significant snow buildup, mount the outdoor unit on a raised, field-provided platform or stand. The raised support platform must be high enough to allow the unit to remain above possible snow drifts, and must be higher than the maximum anticipated snowfall for the location.
5. Design the mounting base to prevent snow accumulation on the platform in front or back of the unit frame.
6. Provide a field fabricated snow protection hood to keep snow and ice and/or drifting snow from accumulating on the coil surfaces.
7. To prevent snow and heavy rain from entering the outdoor unit, install the condenser air inlets and outlets facing away from direct winds.
8. Consider tie-down requirements in case of high winds or where required by local codes.

# PLACEMENT CONSIDERATIONS

MULTI F  
MULTI F MAX

## Selecting the Best Location for the Outdoor Unit

### Planning for Snow and Ice, continued.

#### ⚠ CAUTION

When deciding on a location to place the outdoor unit, be sure to choose an area where run-off from defrost will not accumulate and freeze on sidewalks or driveways, which will create unsafe conditions. Properly install and insulate any drain hoses to prevent the hose from freezing, cracking, leaking, and causing unsafe conditions from frozen condensate.

### Rooftop Installations

If the outdoor unit is installed on a roof structure, be sure to level the unit. Ensure the roof structure and anchoring method are adequate for the unit location. Consult local codes regarding rooftop mounting.

### Oceanside Installation Precautions

- Install the outdoor unit on the side of the building opposite from direct ocean winds.
- Select a location with good drainage.
- Periodically clean dust or salt particles off of the heat exchanger with water.



Avoid installing the outdoor unit where it would be directly exposed to ocean winds.

#### Note:

Additional anti-corrosion treatment will need to be applied to the outdoor unit at oceanside locations.

### Tie-Downs and Lightning Protection

#### Tie-Downs

- The strength of the roof must be checked before installing the outdoor units.
- If the installation site is prone to high winds or earthquakes, when installing on the wall or roof, securely anchor the mounting base using a field-provided tie-down configuration approved by a local professional engineer.
- The overall tie-down configuration must be approved by a local professional engineer. Always refer to local code when using a wind restraint system.

#### Lightning Protection

- To protect the outdoor unit from lightning, it must be placed within the specified lightning safety zone.

Table 8: Safety Zone Specifications.

Building Height (feet)	66	98	148	197
Protection Angle (°)	55	45	35	25

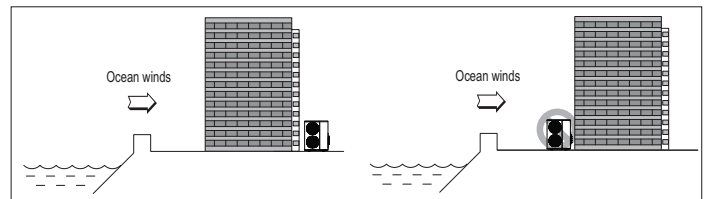
- Power cable and communication cable must be installed five (5) feet away from lightning rod.
- A high-resistance ground system must be included to protect against induced lightning or indirect strike.

#### Note:

If the building does not include lightning protection, the outdoor unit will be damaged from a lightning strike. Inform the customer of this possibility in advance.

#### Note:

Ocean winds will cause corrosion, particularly on the condenser and evaporator fins, which, in turn could cause product malfunction or inefficient performance.



If the outdoor unit must be placed in a location where it would be subjected to direct ocean winds, install a concrete windbreaker strong enough to block any winds. Windbreaker height and width must be more than 150% of the outdoor unit, and be installed at least 27-1/2 inches away from the outdoor unit to allow for airflow.

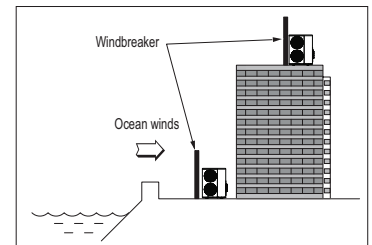
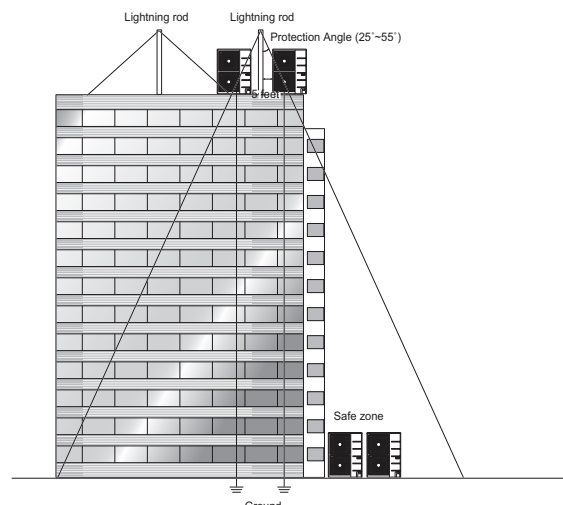


Figure 6: Lightning Protection Diagram.



### Minimum Allowable Clearance and Service Access Requirements

Proper clearance for the outdoor unit coil is critical for proper operation. When installing the outdoor unit, consider service, inlet and outlet, and minimum allowable space requirements as illustrated in the diagrams on the following pages.

- Include enough space for airflow and for service access. If installing multiple outdoor units, ⓧ avoid placing the units where the discharge of one unit will blow into the inlet side of an adjacent unit.
- If an awning is built over the unit to prevent direct sunlight or rain exposure, make sure that the discharge air of the outdoor unit isn't restricted.
- ⓧ No obstacles to air circulation around the unit; keep proper distances from ceilings, fences, floor, walls, etc. (Install a fence to prevent pests from damaging the unit or unauthorized individuals from accessing it.)

### Multi F Outdoor Unit (18,000, 24,000, 30,000, and 36,000 Capacities) Service Access and Allowable Clearances

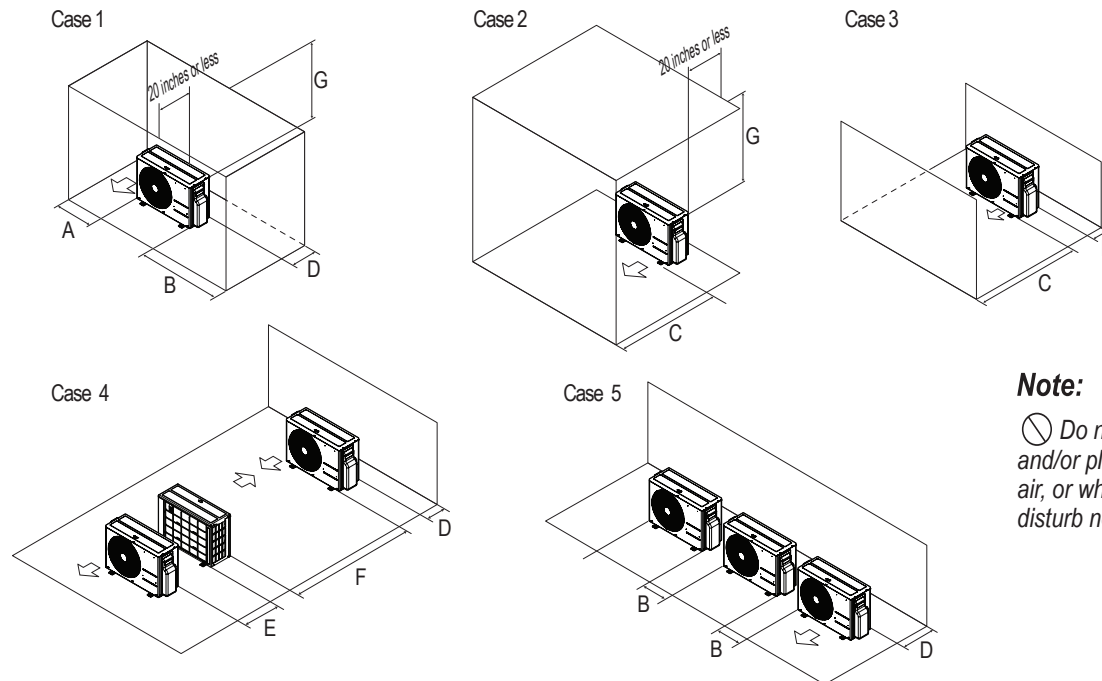
Specific clearance requirements in the diagram below are for 18,000, 24,000, 30,000, 36,000 Btu/h capacities. The figure below shows the overall minimum clearances that must be observed for safe operation and adequate airflow around the outdoor unit.

When placing the outdoor unit under an overhang, awning, sunroof or other "roof-like structure", observe the clearance requirements (as shown in Cases 1 and 2) for height in relation to the unit. To have successful service access to the outdoor unit, see the figure below for minimum spacing. When installing multiple outdoor units, see Cases 4 and 5 for correct spacing requirements.

#### Note:

If the outdoor unit is installed between standard and minimum clearances, capacity decreases approximately 10%.

Figure 7: Multi F 18,000, 24,000, 30,000, and 36,000 Capacity Outdoor Unit Service Access and Allowable Clearances Diagram.



#### Note:

ⓧ Do not place the unit where animals and/or plants will be in the path of the warm air, or where the warm air and/or noise will disturb neighbors.

Table 9: Multi F 18,000, 24,000, 30,000, and 36,000 Outdoor Unit Service Access and Allowable Clearances Diagram Legend.

Unit: Inch		A	B	C	D	E	F	G
Case 1	Standard	12	24	-	12	-	-	-
	Minimum	4	10	-	4	-	-	40
Case 2	Standard	-	-	20	-	-	-	-
	Minimum	-	-	14	-	-	-	40
Case 3	Standard	-	-	20	12	-	-	-
	Minimum	-	-	14	4	-	-	-
Case 4	Standard	-	-	-	12	24	-	-
	Minimum	-	-	-	4	8	79	-
Case 5	Standard	-	24	-	12	-	-	-
	Minimum	-	10	-	4	-	-	-

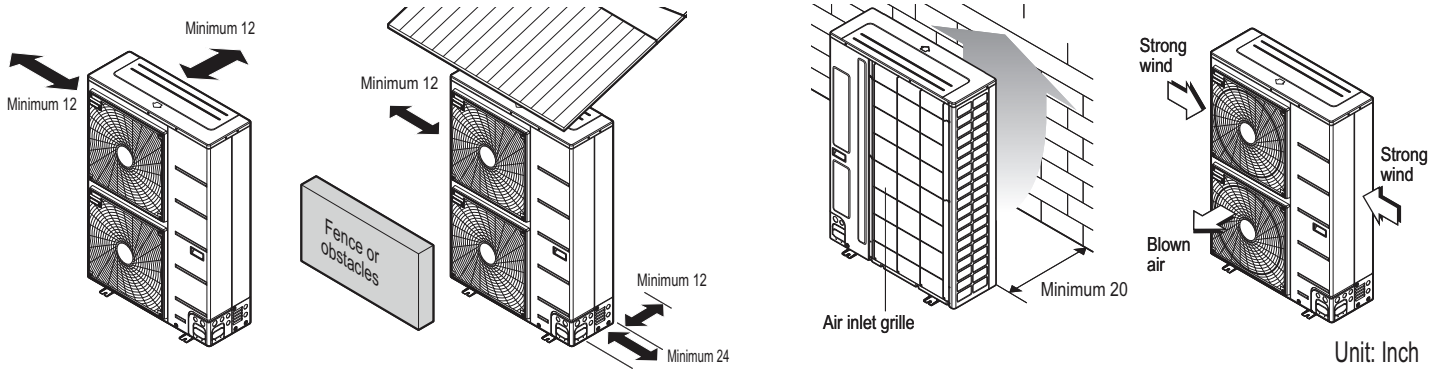
# PLACEMENT CONSIDERATIONS

MULTI F  
MULTI F MAX

## Selecting the Best Location for the Outdoor Unit

### Multi F MAX Outdoor Unit (48,000, 54,000 and 60,000 Btu/h Capacity) Service Access and Allowable Clearances

When installing the outdoor unit, consider service, inlet, and outlet, and minimum allowable space requirements as illustrated in the following diagrams.



Ensure that the space at the back of the outdoor unit is a minimum of 12 inches, and include a minimum of 24 inches at the right side of the unit for service.

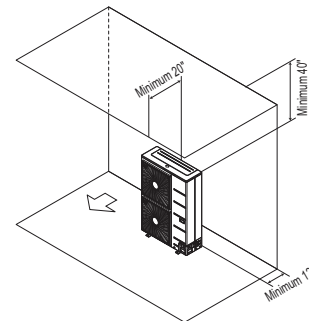
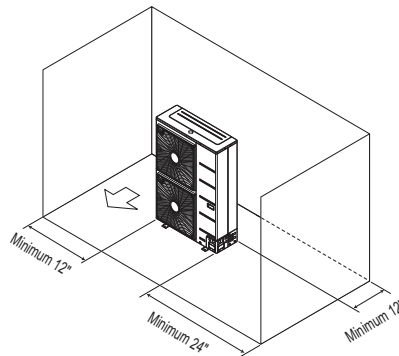
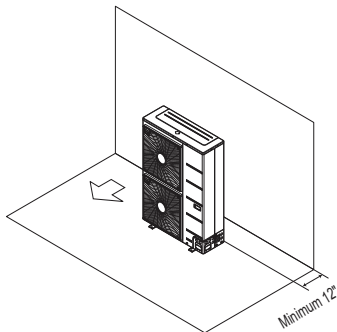
If the outdoor unit discharge side faces a wall, include a minimum of 20 inches between the outdoor unit and the wall. Install the outdoor unit so that the discharge port is set at a right angle to the wind direction.

### Clearance Requirements when Different Obstacles are Present (Unit: Inch).

Obstacle on the suction side only.

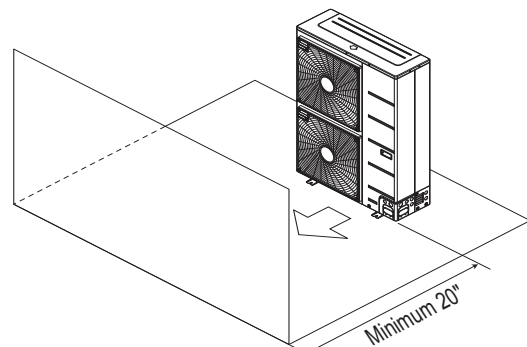
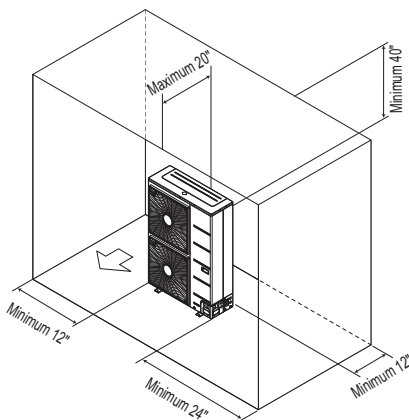
Obstacles on the suction side and on both left and right sides.

Obstacles above and on the air intake side.



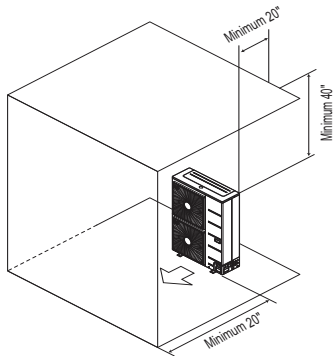
Obstacles above, on the air intake side, and on both left and right sides

Obstacle just on the air discharge side.

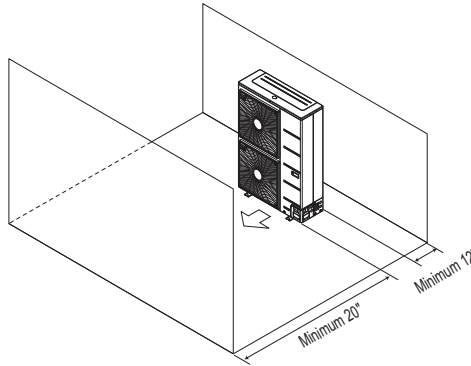


### Clearance Requirements when Different Obstacles are Present, continued. (Unit: Inch)

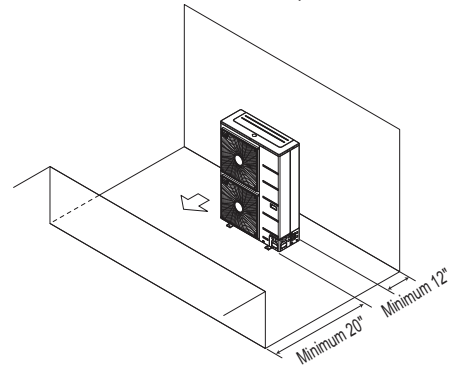
Obstacles above and on the air discharge side.



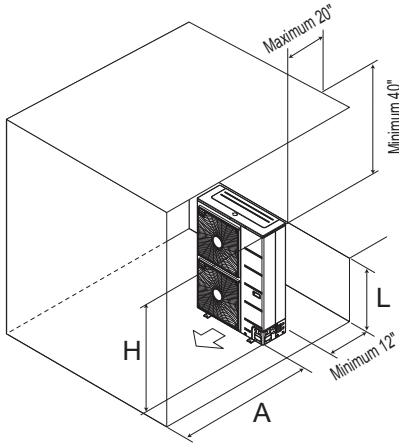
Where there are obstacles on both suction and discharge sides (discharge side obstacle is higher than the outdoor unit).



Where there are obstacles on both suction and discharge sides (discharge side obstacle is lower than the outdoor unit).



Where there are obstacles above, and on both suction and discharge sides (discharge side obstacle is higher than the outdoor unit).



Where there are obstacles above, and on both suction and discharge sides (discharge side obstacle is lower than the outdoor unit).

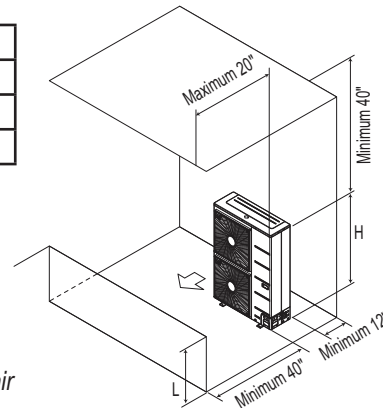


Table 10: Ratio among H, A, and L.

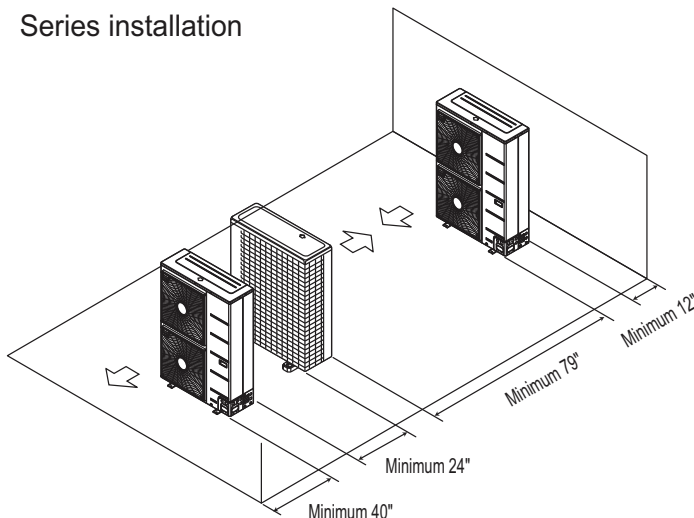
	L	A
L ≤ H	0 < L ≤ 1/2 H	30 inches
	1/2 H < L	40 inches
H < L	Set Stand as: L ≤ H	

If a stand is necessary, it must be contained (not open frame) to prevent the discharge air from short cycling.

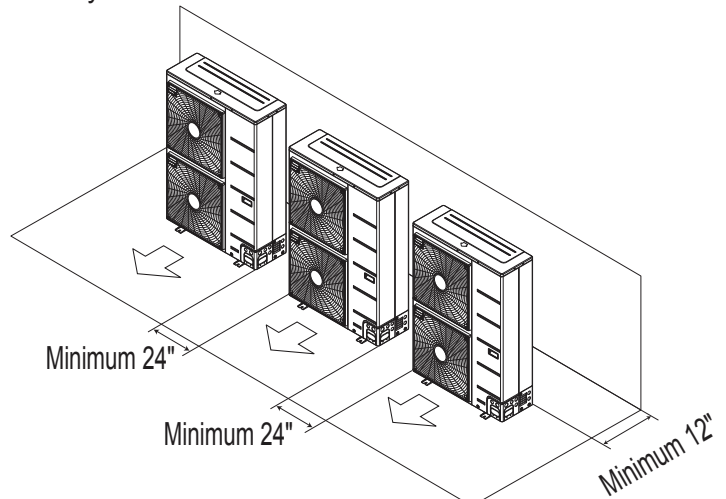
**Note:**

“L” must be lower than “H”. If a stand is necessary, it must be contained (not open frame) to prevent the discharge air from short cycling.

### Series installation



### Side-by-side series installation.





# PLACEMENT CONSIDERATIONS

## Selecting the Best Location for the Outdoor Unit

MULTI F  
MULTI F MAX

---

---

### Installing Outdoor Units Indoors

LG Multi F / Multi F MAX outdoor units are engineered to be mounted outdoors and include technology designed to minimize the negative effects of winter weather's freezing rain, sleet, and snow. Some building projects, however, necessitate placing the HVAC outdoor units indoors:

- Lack of ground space.
- Lack of an appropriate outdoor location that meets system design requirements.
- When mounting on the roof is not an option due to a lack of roof space.
- Roof warranty will be voided if mechanical equipment is placed on the membrane.
- On retrofit projects, a former chiller / boiler / air handler equipment room, mechanical area, or penthouse already exists.
- To curtail the potential need for redundant zone heating devices such as wall-fin radiators or duct heaters.
- In extremely cold environments where there is a significant amount of run-time at temperatures well below freezing outside the outdoor unit ambient air temperature range published in this engineering manual.

#### Benefits of Installing Outdoor Units Indoors

- Shelters the outdoor unit from direct exposure to prevailing winds that decrease the heating capability of the outdoor unit.
- Protects equipment from freezing precipitation and/or potential ice build-up that could hinder unit operation.
- Maintains coil heat transfer efficiency by reducing the number of and shortening the cycle time for defrost operation.
- Easier maintenance and servicing during inclement weather.
- When mounted in a fully enclosed space, limiting the ambient air temperature will allow the Multi F / Multi F MAX system designer to eliminate oversizing.
- The outdoor unit to compensate for loss of capacity at low ambient temperatures.
- Will also curtail the need to provide inefficient redundant zone heating devices such as wall-fin radiators and second-stage ancillary heating devices.

#### Design Considerations Include:

- Enclosure types and elements such as louvers (see next page), rain hoods, dampers and controls, heating methods and sizing of heating devices.
- Heating strategies.
- Duct design.
- Condensate handling.

#### General Guidelines

- Follow ASHRAE 62.1 design guidelines.
- Depending on the project / application, a roof over the outdoor units in combination with a wind break will be all that is necessary.
- Consider the potential for snow accumulation near louvers / roof openings. Outside air intakes and discharge ducts/louvers must be engineered to clear anticipated snow accumulation levels by at least one (1) foot.
- In situations where operation is anticipated at temperatures of -13°F and lower, ancillary heat must be provided to heat the outdoor unit coils to assure continuous compressor operation and heating.

It will be necessary to use a field-fabricated air guide to prevent discharge air from short-cycling back to the coil inlet.

- Consider the direction of prevailing winds and opening placement. If possible, locate inlet openings upwind of discharge openings and other exhaust outlets.
- When inlet and outlet openings are placed on the same wall, minimum distance between the two openings must be approximately three (3) feet (minimum distance varies significantly with variations in outlet opening face velocity).
- If roof-mounted ventilation openings are used, strategically locate the inlet ventilation opening(s) upwind of the outlet opening(s).
- Discharge and supply ductwork must be designed to avoid weather related long periods of water entrainment and the potential for microbial growth.

Provide a means to drain the condensate generated during heating mode and defrost cycle in addition to rainwater that infiltrates the inlet louver enclosed area.

- Install a field-provided drain pan under the outdoor units and provide a path to a nearby floor drain.
- If the ambient air temperature is expected to drop below 32°F in the enclosure, heat the bottom surface of the pan, drain line, and floor drain so that the condensate does not freeze before reaching the drain.

### ⚠ CAUTION

When deciding on a location to place the outdoor unit, be sure to choose an area where run-off from defrost will not accumulate and freeze on sidewalks or driveways which will create unsafe conditions.

Allow for ventilation intake and exhaust air based on maximum outdoor unit fan capacity.

- Select the size, type and orientation of architectural louvers with adequate “net free area” face velocity to ensure the total external static pressure from the outdoor unit fan does not exceed design limitations (see specification data tables).
- No obstructions must be placed in front of the louver that could hamper the free flow (throw) of air.
- Roof top openings and / or discharge and supply louvers must be equipped with screens to prevent bird and insect infiltration.

### Note:


For louver recommendations, see below and on the next page.

As always, the best solution for each project balances acceptable heating performance (considering local weather conditions), capital costs, life cycle energy consumption, and limitations set forth by local building codes.

## Louver Recommendations for Outdoor Unit Enclosure

1. Outdoor Unit Enclosure: Manual Door Open Type.
2. Louver Angle: No More Than 15° Horizontally.
3. Space Between Louvers: More than 4 inches (Recommend).
4. Louver Shape: Wing or Plane Type.

### Note:

- Open Rate and Inlet must be taken into consideration when designing the louvered outdoor unit enclosure.
-  Do not use “S” type louvers.

### Note:

#### If the Louver Open Rate is Too Small

1. Noise can occur because of the increased air velocity passing through the louver blade.
2. Noise can occur from louver blade vibrations.
3. A drop in outdoor unit fan performance (excess static pressure can cause a drop in outdoor unit performance and heat exchanger efficiency).
4. If the louver open rate is too small or there is insufficient air flow exchange, the air conditioner might stop operating.

Figure 8: Louver Recommendations.

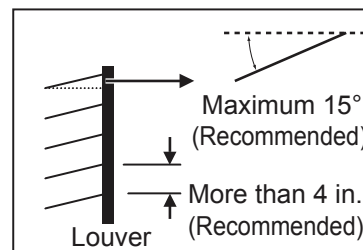
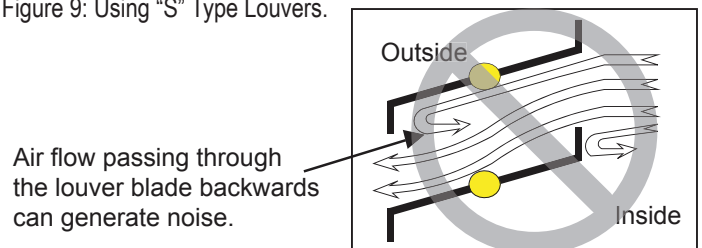


Figure 9: Using “S” Type Louvers.



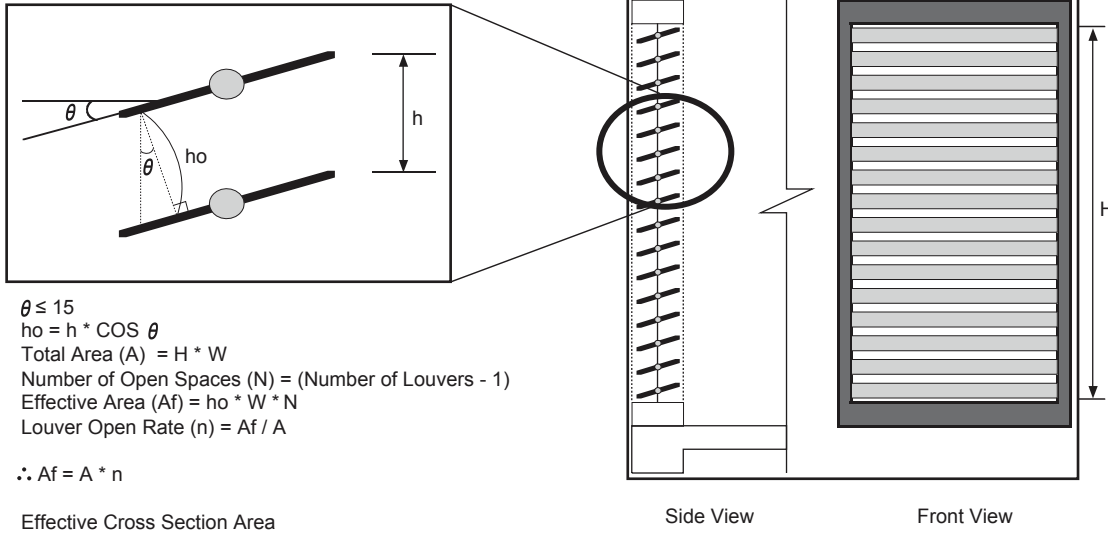
# PLACEMENT CONSIDERATIONS

## Selecting the Best Location for the Outdoor Unit

MULTI F  
MULTI F MAX

### Open Rate by Louver Radian

Figure 10: Open Rate by Louver Radian Formula.



### Confirming Air Flow Rate / Total Opening Rate

• Example: LMU36CHV

• Airflow Rate: 2,119 ft.<sup>3</sup>/min.

• Velocity of Outlet Air: 16.4 ft./s

• Velocity of Inlet Air: 8.2 ft./s

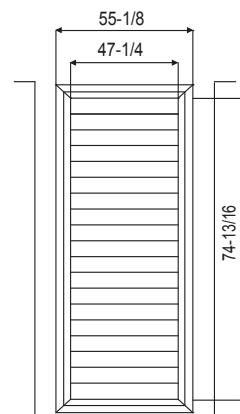
• Open Rate = 80% or More

$$\text{Open Rate} = \frac{\text{Effective Face Area (Af)}}{\text{Total Face Area (A)}}$$

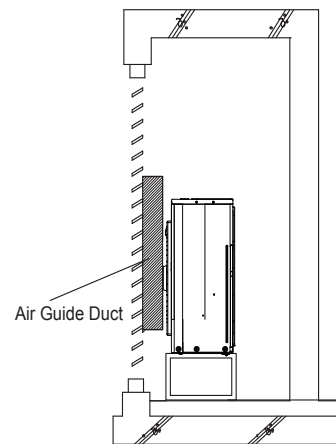
• Discharge Air Guide must be installed.

Figure 11: Example of Installing Outdoor Unit Indoors.

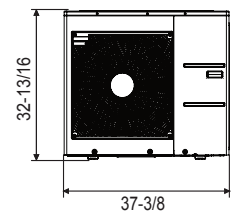
#### Louver Dimensions



#### Air Guide Duct on Outdoor Unit



#### Outdoor Unit Dimensions



### Formula

• Total Louver Dimension (Excluding Frame) (A) = 3.9 feet x 6.2 feet = 24.2 ft.<sup>2</sup>

• Louver Shield Dimension by Product (B) = 3.12 feet x 2.74 feet = 8.55 ft.<sup>2</sup>

• Inlet Louver Dimension (A - B) = 15.7 ft.<sup>2</sup>

• Equivalent Inlet Dimension (Open Rate 80%) = 15.7 ft.<sup>2</sup> x 0.8 = 12.56 ft.<sup>2</sup>

• Equivalent Inlet Air Volume = 12.56 ft.<sup>2</sup> x 8.2 ft./s x 60 sec./min. = 6,179.5 ft.<sup>3</sup>/min.

• Required Air Volume / Equivalent Volume = 6,179.5 ft.<sup>3</sup>/min. / 2,119 ft.<sup>3</sup>/min. = 291% (Within Allowable Limits)



### Selecting the Best Location for the Indoor Units

#### Note:

Select a location for installing the indoor units that will meet the following conditions:

- Within allowable parameters for proper connection to the outdoor unit (and branch distribution unit, if a Multi F MAX system).
- So that condensation drainage can be conveniently routed away.
- Include enough space around the indoor unit so that it is accessible for maintenance and service purposes.
- Where electrical noise / electromagnetic waves will not affect indoor unit operation. Maintain proper distances between the indoor units and electric wires, audio and visual appliances, breaker / circuit panels, etc. If the frequency signal of the appliance is unstable, then install the indoor unit a minimum of ten (10) feet away, and run the power and transmission cables through a conduit.
- An area that is level and with enough strength to bear the weight of the indoor unit(s).

#### Do Not's

- Install in an area with obstacles to air circulation around the unit; keep proper distances from ceilings, doorways, floor, walls, etc.
- Install in an area where operation sound will disturb occupants.
- Install in an area that exposes the indoor unit(s) to heat, water, steam, oil splattering or spray.

#### Note:

Indoor units (IDUs) must not be placed in an environment where the IDUs will be exposed to harmful volatile organic compounds (VOCs) or in environments where there is improper air make up or supply or inadequate ventilation. If there are concerns about VOCs in the environment where the IDUs are installed, proper air make up or supply and / or adequate ventilation must be provided. Additionally, in buildings where IDUs will be exposed to VOCs consider a factory-applied epoxy coating to the fan coils for each IDU.

For detailed placement considerations and installation requirements for indoor units, refer to its Indoor Unit Engineering and / or Installation Manuals.

### Selecting the Best Location for the Branch Distribution (BD) Units

#### Note:

Branch distribution (BD) units are used only with Multi F MAX systems to distribute the refrigerant from the outdoor unit up to eight (8) indoor units.

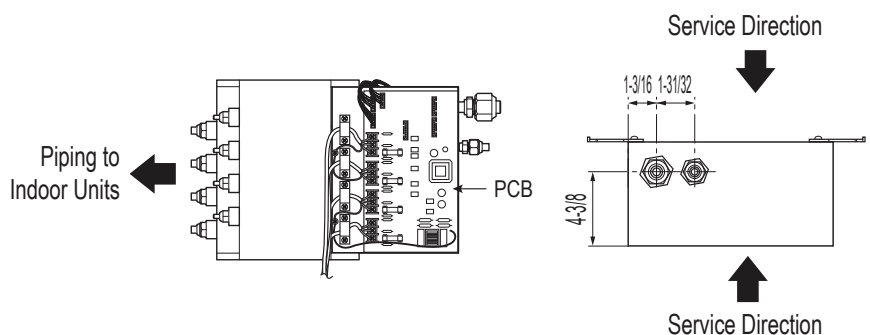
Select a location indoors that will meet the following conditions:

- Within allowable parameters for proper connection to the Multi F MAX outdoor unit and indoor unit(s); refrigerant piping and wire lengths must not exceed amounts specified by LG Electronics, U.S.A., Inc.
- Condensate drain piping is not required.
- Ensure there is enough space in the installation area for service purposes (minimum 24 inches); install the refrigerant piping and electrical wiring system in an easily accessible location.
- Level where there is enough strength to bear the weight of the branch distribution unit.

#### Do Not's

- Install the branch distribution unit in a location where it would be subjected to strong radiation heat from heat sources.
- Install in an installation environment where the branch distribution unit would be exposed to heat, water, steam, oil splattering or spray.
- Install the unit in a location where any sound it generates will disturb occupants in the surrounding rooms.
- Install in a location where there are obstacles to air circulation around the unit; keep proper distances from ceilings, doorways, floor, walls, etc.
- Install in an area where high-frequency electrical noise / electromagnetic waves will affect operation. Maintain proper distances between the branch distribution unit(s) and electric wires, audio and visual appliances, breaker / circuit panels, etc.

Figure 12: Branch Distribution Unit Key Components.



# PLACEMENT CONSIDERATIONS

Selecting the Best Location for the Branch Distribution Units

MULTI F  
MULTI F MAX

MULTI F / MULTI F MAX Outdoor Unit Installation Manual

A-C (and PMBD3640 D) Connections:

Liquid Pipe  $\varnothing 1/4$

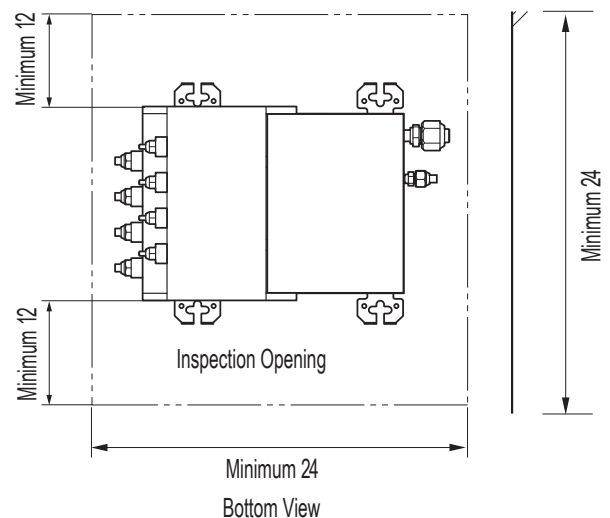
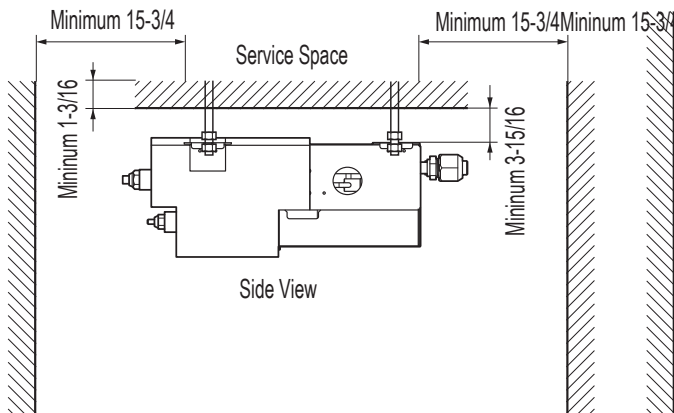
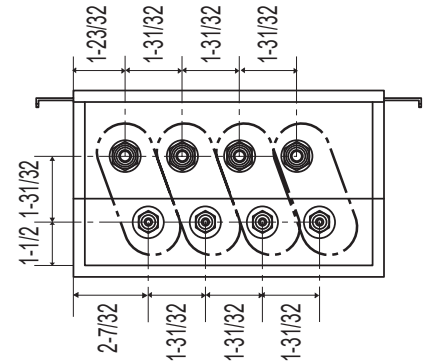
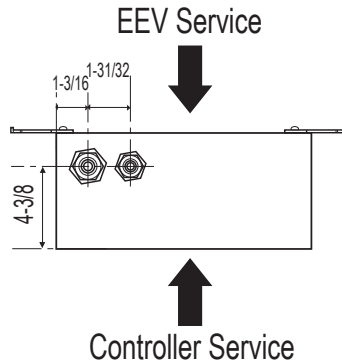
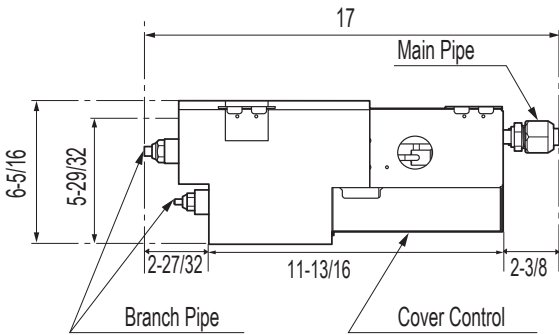
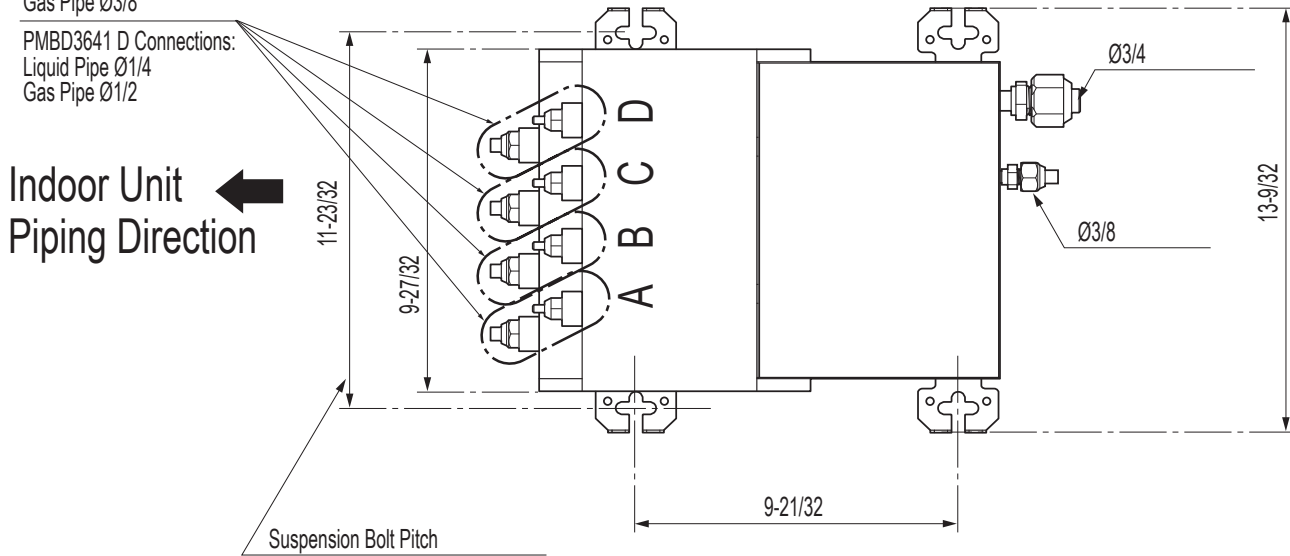
Gas Pipe  $\varnothing 3/8$

PMBD3641 D Connections:

Liquid Pipe  $\varnothing 1/4$

Gas Pipe  $\varnothing 1/2$

Unit: Inch



Notes:

1. For PMBD3620 Unit, Ports A and B are Available.
2. For PMBD3630 Unit, Ports A, B, and C are Available.
3. For PMBD3640 and PMBD3641 Units, Ports A, B, C, and D are Available.

## Mounting / Anchoring the Outdoor Unit General Specifications

- Tightly anchor the outdoor unit with a bolt and nut to a concrete or rigid platform.
- When installing on a wall (with field-supplied brackets), roof, or rooftop, securely anchor the mounting platform with nails and / or wiring, taking into consideration the possibility of strong winds or earthquakes.
- If installing the outdoor unit on the roof, check the strength of the roof.

### Outdoor Unit Platform Concrete Specifications

- Concrete foundations must be made of one part cement, two parts sand, and four parts gravel.
- The surface of the foundation must be finished with mortar with rounded edges, and weatherproofed.
- See table and figures for height, width, etc., requirements.
- Include an area for drainage around the foundation to ensure condensate thoroughly drains away from the outdoor unit.

Figure 14: Close up of Bolt Attachment.

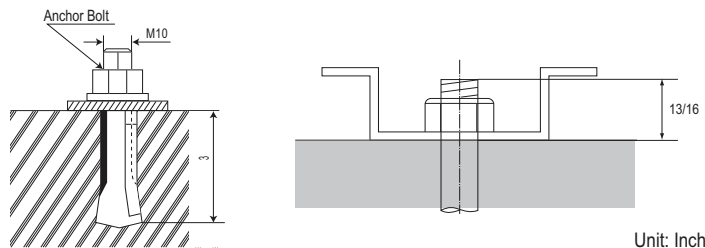


Figure 15: LMU180HV and LMU240HV Outdoor Units.

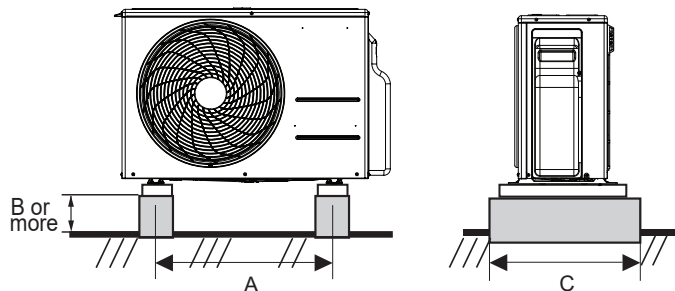


Figure 17: LMU30CHV and LMU36CHV Outdoor Units.

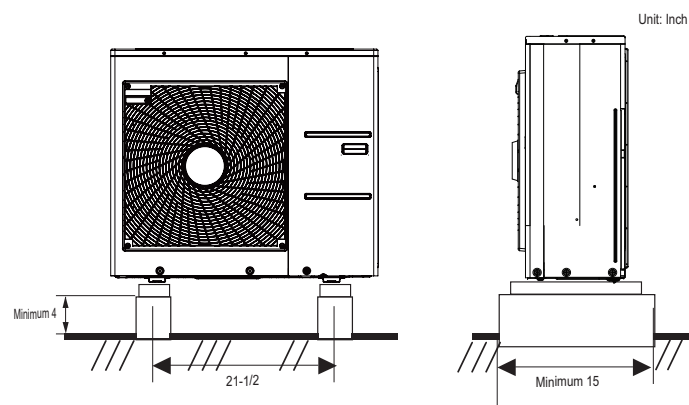


Figure 13: Example of Using an Insert for a Hole in a Reinforced Concrete Beam.

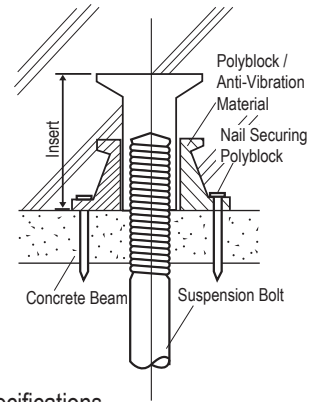


Table 11: Outdoor Unit Foundation Specifications.

Outdoor Unit	Bolt Type	Concrete Height	Bolt Depth
LMU180HV, LMU18CHV, LMU240HV, LMU24CHV, LMU30CHV, LMU36CHV	M10-J	Minimum Four (4) Inches	Minimum Three (3) Inches
LMU480HV, LMU540HV, LMU600HV	M10-J	Minimum Eight (8) Inches	Minimum Three (3) Inches

Figure 16: LMU18CHV and LMU24CHV Outdoor Units.

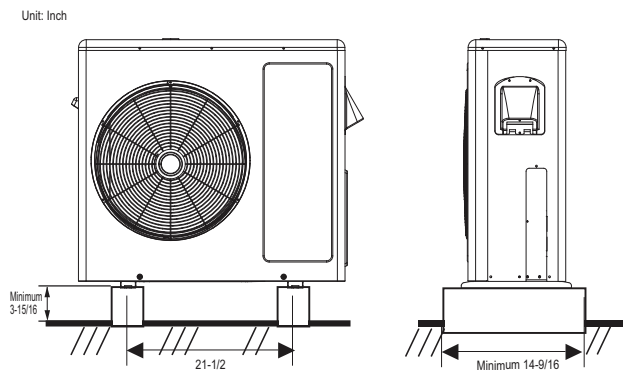
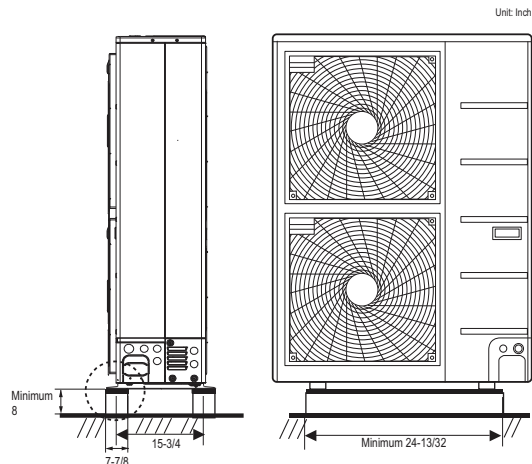


Figure 18: LMU480HV, LMU540HV, LMU600HV Outdoor Units.



# MOUNTING / ANCHORING THE OUTDOOR / BRANCH DISTRIBUTION UNITS

MULTI F  
MULTI F MAX

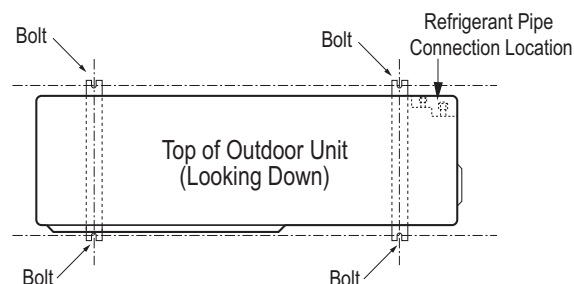
MULTI F / MULTI F MAX Outdoor Unit Installation Manual

## Mounting / Anchoring the Outdoor Unit General Specifications, continued.

### Bolting the Outdoor Unit to the Platform Procedure

1. Ensure that the concrete platform will not degrade easily, and has enough strength to bear the weight of the unit.
2. Include an H-beam support. Firmly attach the corners, otherwise the support will bend.
3. Use a hexagon nut.
4. If there is a possibility of vibration from the outdoor unit transmitting to the building, add an anti-vibration material to the platform.
5. Include enough space around the concrete foundation for condensate drainage.
6. Seal all wiring and piping access holes with field-supplied sealing material to prevent animals and bugs from entering the unit.

Figure 20: Bolting the Outdoor Unit to the Platform (Piping Location Will Differ Depending on Outdoor Unit Model).



### Branch Distribution Unit Orientation

Multi F MAX branch distribution (BD) units can be installed in a multitude of options to fit various building configurations and job or application requirements (suspended from the ceiling or mounted on the wall). The installation location of the PCB within the branch distribution unit can be changed for easier service access, depending on the branch distribution unit installation itself (see the wiring section for information). Branch distribution units include electronic expansion valves that properly seat only if the branch distribution unit is installed in an acceptable orientation. Installations with improper branch distribution unit orientation risk incomplete valve seating and system performance degradation from potential refrigerant leakage through the electronic expansion valve.

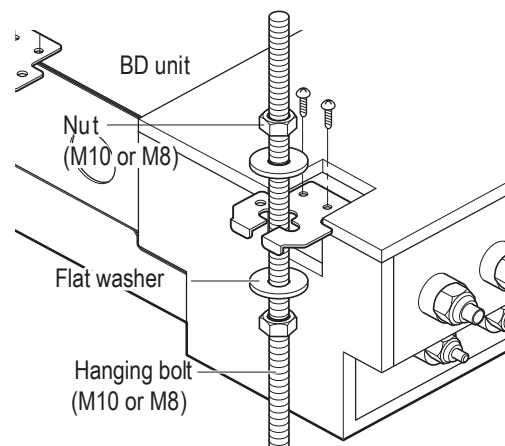
### Note:

*This material is for informational or educational purposes only. It is not intended to be a substitute for professional advice. Consult with your engineer or design professionals for specific applications to your system.*

### Ceiling Mount Installation - Hangers with Hanging Bolt

1. Drill four (4) holes in the ceiling, following the dimensions on the previous page.
2. Attach the factory-supplied hangers with two (2) screws each at the designated four (4) areas on the frame of the branch distribution unit.
3. Install an anchor in the ceiling, and attach the hanging bolts to the ceiling.
4. Add nuts and washers to the hanging bolt as shown at right.
5. Hang the branch distribution unit on the hanging bolts (ceiling side up), and after checking for level ( $\pm 5$  degrees), securely tighten all nuts.

Figure 19: Branch Distribution Ceiling Mount Installation.



### Ceiling Mount Installation - Hangers Only

1. Attach the factory-supplied hangers with two (2) screws each at the designated four (4) areas on the frame of the branch distribution unit.
2. Install the branch distribution unit to the ceiling using two screws on each of the hangers as shown below. Unit must be  $\pm 5$  degrees of level.
3. Cover parts of the hanger holes with polyethylene foam insulation (to prevent condensation).

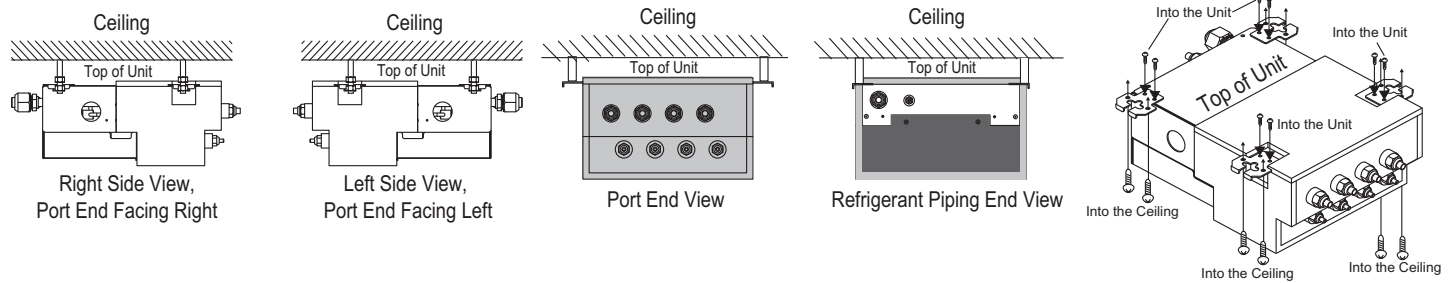
### Note:

*If a screw has been installed on the frame of the branch distribution unit and the screw has been removed, to prevent condensation, either re-install the screw or cover the open hole with aluminum tape.*

## Ceiling Mount Installation, continued.

Figure 21: Acceptable Branch Distribution Unit Ceiling Mount Orientations.

### Ceiling Mounting Options



## Wall Mount Installation - Hangers Only

1. Attach the factory-supplied hangers with two (2) screws each at the designated four (4) areas on the frame of the branch distribution unit.
2. Install the branch distribution unit to the wall using two screws on each of the hangers. Unit must be  $\pm 5$  degrees of level.
3. Cover parts of the hanger holes with polyethylene foam insulation (to prevent condensation).

Figure 22: Acceptable Branch Distribution Unit Orientation.

### Wall Mounting Options

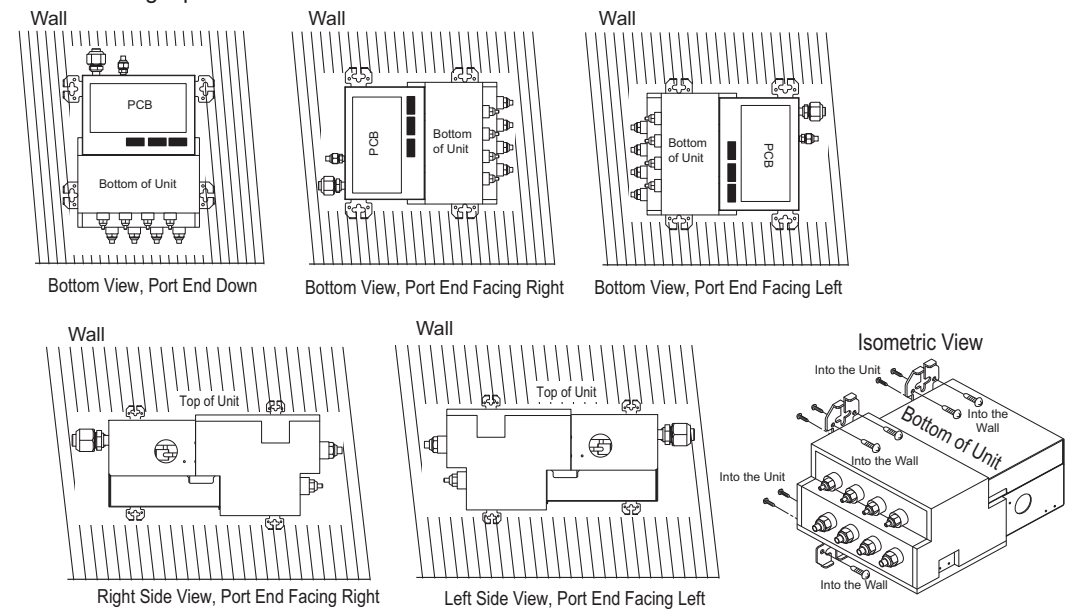
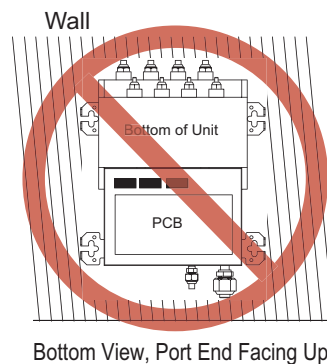


Figure 23: Unacceptable Branch Distribution Unit Wall Mount Orientations.





# LG AIR CONDITIONER TECHNICAL SOLUTION (LATS)

MULTI F  
MULTI F MAX

## LG Air Conditioner Technical Solution (LATS) Software

A properly designed and installed refrigerant piping system is critical to the optimal performance of LG air-conditioning systems. To assist engineers, LG offers, free of charge, LG Air Conditioner Technical Solution (LATS) software—a total design solution for LG air conditioning systems.

### Note:

To reduce the risk of designing an improper applied system or one that will not operate correctly, LG prefers that LATS software be used on all projects.

### Formats

LATS is available to LG customers in three user interfaces: LATS HVAC, LATS CAD2, and LATS Revit. All three LATS formats are available through [www.myLGHVAC.com](http://www.myLGHVAC.com), or contact an LG Sales Representative.

**LATS HVAC** is a Windows®-based application that aids engineers in designing LG Variable Refrigerant Flow (VRF), Multi F / Multi F MAX, Multi F / Multi F MAX with LGRED, Single-Zone, and Energy Recovery Ventilator (ERV) systems.

\*Windows® is a registered mark of Microsoft® Corporation.

**LATS CAD2** combines the LG LATS program with AutoCAD® software\*\*. It permits engineers to layout and validate LG Multi V Variable Refrigerant Flow (VRF), Multi F / Multi F MAX, Multi F / Multi F MAX with LGRED, Single-Zone, and Energy Recovery Ventilator (ERV) systems directly into CAD drawings.

**LATS Revit** integrates the LG LATS program with Revit® software\*\*. It permits engineers to layout and validate Multi V VRF systems directly into Revit drawings.

\*\*AutoCAD® and Revit® are both registered marks of Autodesk, Inc.

Figure 24: Example of LATS CAD2.



### Features

All LG product design criteria have been loaded into the program, making LATS simple to use: double click or drag and drop the component choices. Build systems in Tree Mode where the refrigerant system can be viewed. Switch to a Schematic diagram to see the electrical and communications wiring.

LATS software permits the user to input region data, indoor and outdoor design temperatures, modify humidity default values, zoning, specify type and size of outdoor units and indoor units, and input air flow and external static pressure (ESP) for ducted indoor units.

The program can also:

- Import building loads from a separate Excel file.
- Present options for outdoor unit auto selection.
- Automatically calculate component capacity based on design conditions for the chosen region.
- Verify if the height differences between the various system components are within system limits.
- Provide the correct size of each refrigerant piping segment and LG Y-Branches and Headers.
- Adjust overall piping system length when elbows are added.
- Check for component piping limitations and flag if any parameters are broken.
- Factor operation and capacity for defrost operation.
- Calculate refrigerant charge, noting any additional trim charge.
- Suggest accessories for indoor units and outdoor units.
- Run system simulation.

### Note:

Features depend on which LATS program is being used, and the type of system being designed.

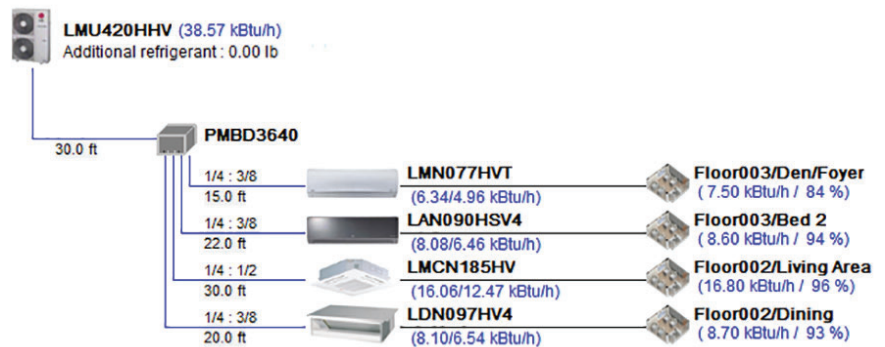
## LATS Generates a Complete Project Report

LATS software also generates a report containing project design parameters, cooling and heating design data, system component performance, and capacity data. The report includes system combination ratio and refrigerant charge calculations; and provides detailed bill of material, including outdoor units, indoor units, control devices, accessories, refrigerant pipe sizes segregated by building, by system, by pipe size, and by pipe segments. LATS can generate an Excel GERP report that can imported into the LG SOPS pricing and ordering system.

## Proper Design to Install Procedure

LG encourages a two report design-to-install-procedure. After the design engineer determines building / zone loads and other details, the engineer opens the LATS program and inputs the project's information. When the design is complete, the "Auto Piping" and "System Check" functions must be used to verify piping sizes, limitations, and if any design errors are present. If errors are found, engineers must adjust the design, and run Auto Piping and System Check again. When the design passes the checks, then the engineer prints out a project "Shop Drawing" (LATS Tree Diagram) and provides it to the installing contractor. The contractor must follow the LATS Tree Diagram when building the piping system, but oftentimes the design changes on the building site:

Figure 25: Example of a LATS Tree Diagram.



- Architect has changed location and/or purpose of room(s).
- Outdoor unit cannot be placed where originally intended.
- Structural elements prevent routing the piping as planned.
- Air conditioning system conflicts with other building systems (plumbing, gas lines, etc.).

The contractor must mark any deviation from the design on the Shop Drawing, including as-built straight lines and elbows. This "Mark Up" drawing must be returned to the design engineer or Rep, who must input contractor changes into the LATS file. (Copy the original LATS software file, save and rename as a separate file, and modify all piping lengths by double-clicking on each length and editing information.) Like the shop drawing, the Auto Piping and System Check must also be run on this new "As Built" drawing. The design engineer or Rep must then provide the final As Built file to the contractor. The Mark Up version must be compared to the As Built version for:

- Differences in pipe diameter(s). If incorrect diameters have been installed, the piping must be changed out. If pipe diameters have changed, check to see if Y-Branches will also need to be changed.
- Changes to outdoor unit and indoor unit capacities. Capacities changes will impact line length changes.
- Additional refrigerant charge quantity ("Trim Charge"). Trim charge will change if piping lengths and diameters change. The As Built version must reflect installed piping lengths to ensure correct trim charge.

All documents submitted by the contractor, as well as the Shop Drawing and the As Built Drawing files must be provided for commissioning purposes. Model and serial numbers for all system components must also be submitted. If the steps previously detailed are not followed, and all documents are not provided to the commissioning agent, the project runs the risk of not being commissioned and voiding any limited warranty LG offers on the equipment.

## Note:

Contact your LG representative for the vest software program for your application.

# REFRIGERANT SAFETY STANDARDS / DEVICE CONNECTION LIMITATIONS

MULTI F  
MULTI F MAX

## Refrigerant Safety Standards

ASHRAE Standards 15-2010 and 34-2010 address refrigerant safety and the maximum allowable concentration of refrigerant in an occupied space. Refrigerant will dissipate into the atmosphere, but a certain volume of air is required to safely dissipate the refrigerant. For R410A refrigerant, the maximum allowable concentration of refrigerant is 26 lbs./1,000 cubic feet (Addendum L modified the RCL to 26) of occupied spaces. Buildings with 24-hour occupancy allow half of that concentration.

If a VRF system develops a refrigerant leak, the entire refrigerant charge of the system will dump into the area where the leak occurs. To meet ASHRAE Standards 15 and 34, the smallest room volume on the system must be calculated and compared to the maximum allowable concentration. If the concentration level is higher than allowed, the following are some design suggestions to eliminate the problem:

- Split dual-frame and triple-frame systems into single-frame systems that have lower refrigerant charges.
- Add transfer grilles in the ceiling or walls of the smaller rooms to increase the volume of the room.
- Remove the smallest space from the system and serve it with a smaller mini-split system.

## Device Connection Limitations

- The minimum number of connected and operating indoor units to Multi F / Multi F MAX systems is two, taking into consideration the minimum combination ratio.
- The maximum number of indoor units for each Multi F / Multi F MAX heat pump systems is:  
LMU18\*HV = 2    LMU24\*HV = 3    LMU30CHV = 4    LMU36CHV = 4    LMU480HV = 8    LMU540HV = 8    LMU600HV = 8

### Note:

For allocated capacity information, see the combination tables in the "Multi F / Multi F MAX Combination Data Manual" on [www.lghvac.com](http://www.lghvac.com). For performance data, see "Multi F / Multi F MAX Performance Data Manual" on [www.lghvac.com](http://www.lghvac.com).

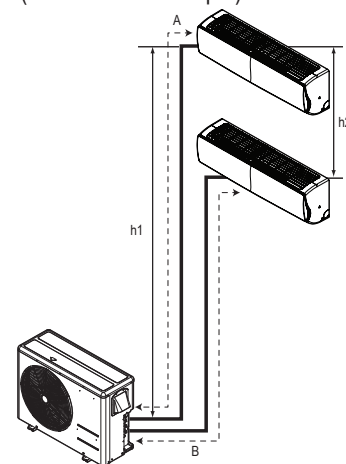
One of the most critical elements of Multi F and Multi F MAX systems is the refrigerant piping. See below and the following pages for pipe length limits that must be followed in the design of Multi F and Multi F MAX refrigerant pipe systems.

## Multi F Outdoor Unit Piping Length and Elevation Limitations

Figure 26: Multi F Refrigerant Piping System Limitations (LMU18CHV Example).

Table 12: Multi F Refrigerant Piping System Limitations.

Outdoor Unit Model (Btu/h)	LMU18*HV 18,000	LMU240HV 24,000	LMU24CHV 24,000	LMU30CHV 30,000	LMU36CHV 36,000
Max. Total System Piping Length (ft.)	164 A+B	230.0 A+B+C	246.1 A+B+C	246.1 A+B+C+D	246.1 A+B+C+D
Min. Length for One Branch (ft.)	10	10	10	10	10
Max. Length for One Branch (ft.)	82	82	82	82	82
Max. Elevation Between Each Indoor Unit and Outdoor Unit (h1)	49.2	49.2	49.2	49.2	49.2
Max. Elevation Between Indoor Units (h2)	24.6	24.6	24.6	24.6	24.6
Max. Combination of Indoor Units	24,000	33,000	33,000	40,000	48,000



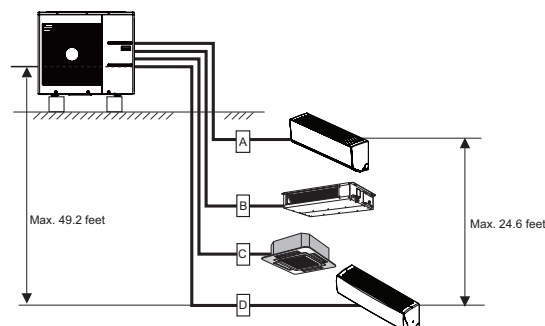
## Multi F System Example

Example: LMU36CHV outdoor unit with four (4) indoor units connected.

ODU: Outdoor Unit.

IDU: Indoor Unit.

A, B, C, D: Pipes from Outdoor Unit to Indoor Unit.





## Multi F MAX Outdoor Unit Piping Length and Elevation Limitations

Table 14: Multi F MAX Refrigerant Piping System Limitations.

Pipe Length (ELF = Equivalent Length of pipe in Feet)	Total piping length ( $\Sigma A + \Sigma B$ )		$\leq 475.7$ feet
	Main pipe (Outdoor Unit to Branch Distribution Units: A)	Minimum for Each (A) Piping Segment	10 feet
		Maximum ( $\Sigma A$ )	$\leq 180.4$ feet
	Total branch piping length ( $\Sigma B$ )		$\leq 295.3$ feet
Branch pipe (Branch Distribution Units to Indoor Units: B)	Minimum	10 feet	
	Maximum	$\leq 49.2$ feet	
Elevation Differential (All Elevation Limitations are Measured in Actual Feet)	If outdoor unit is above or below indoor unit ( $h_1$ )		$\leq 98.4$ feet
	Between the farthest two indoor units ( $h_2$ )		$\leq 49.2$ feet
	Between branch distribution unit and farthest connected indoor unit(s) ( $h_3$ )		$\leq 32.8$ feet
	Between branch distribution units ( $h_4$ )		$\leq 49.2$ feet
Max. Combination of IDUs	LMU480HV = 65,000	LMU540HV = 73,000	LMU600HV = 81,000

Figure 27: Multi F MAX Refrigerant Piping System Limitations.

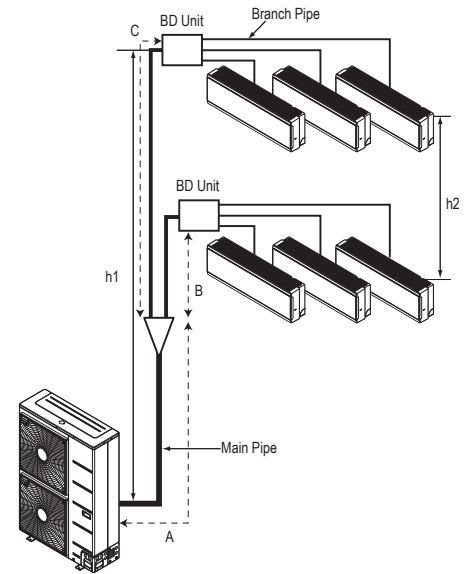


Table 15: Multi F MAX Piping Sizes.

Piping	Main Pipe A (inch)	Branch Pipe B
Liquid	$\varnothing 3/8$	Depends on the size of the indoor unit piping
Gas	$\varnothing 3/4$	

## Multi F MAX System Example with Two Branch Distribution Units

**Example:** LMU540HV outdoor unit with seven (7) indoor units, and two (2) branch distribution units connected.

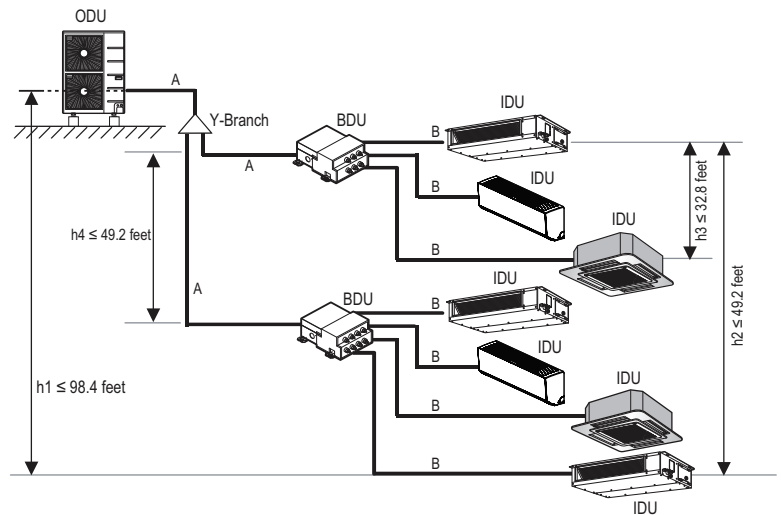
ODU: Outdoor Unit.

IDU: Indoor Unit.

BD: Branch Distribution Unit(s).

A: Main Pipe.

B: Branch Pipe (Branch Distribution Unit[s] to Indoor Unit[s]).



## Using Refrigerant Components

Field-supplied elbows are allowed as long as they are designed for use with R410A refrigerant. The designer, however, must be cautious with the quantity and size of fittings used, and must account for the additional pressure losses in equivalent pipe length calculation for each branch. The equivalent pipe length of each elbow must be added to each pipe segment.

Table 13: Equivalent Piping Length for Elbows, Y-branches, and Branch Distribution Units.

Component	Size (Inches)				
	1/4	3/8	1/2	5/8	3/4
Elbow (ft.)	0.5	0.6	0.7	0.8	1.2
Y-Branch Kit (ft., Multi F MAX systems only) <sup>1</sup>	1.6				
Branch Distribution Unit (ft., Multi F MAX systems only)	8.2				

<sup>1</sup>Kit contains two Y-branches: one for liquid and one for vapor.

## Selecting Field-Supplied Copper Piping

### Note:

Always follow local codes when selecting and installing copper pipe and piping system components.

Approved piping for use with LG HVAC products will be marked "R410 RATED" along the length of the pipe. Piping wall thickness must meet local code requirements and be approved for a maximum operating pressure of 551 psi. When bending piping, try to keep the number of bends to a minimum, and use the largest radii possible to reduce the equivalent length of installed piping; also, bending radii greater than ten (10) piping diameters can minimize pressure drop. Be sure no traps or sags are present.

### For Multi-Zone Split Systems

Use ACR copper piping rated at the system working pressure (rated for R410A refrigerant).

### Note:

Always properly support the piping as per the instructions on page 44.

Table 16: ACR Rated Copper Tubing Material.

Type	Seamless Phosphorous Deoxidized
Class	UNS C12200 DHP
Straight Lengths	H58 Temper
Coils	O60 Temper

Table 17: ACR Rated Piping Wall Thicknesses.

OD (in)	1/4	3/8	1/2	5/8	3/4	7/8	1-1/8	1-3/8	1-5/8
Material	Rigid or Soft ACR Rated for R410A			Rigid or Soft ACR Rated for R410A					
Min. Bend Radius (in)	0.563	0.9375	1.5	2.25	3.0	3.0	3.5	4.0	4.5
Min. Wall Thickness (in)	0.03	0.03	0.03	0.03	0.03	0.03	0.03	0.04	0.050

Table 18: ACR Copper Tubing Dimensions and Physical Characteristics<sup>1-3</sup>.

Nominal Pipe Outside Diameter (in)	Actual Outside Diameter (in)	Tempered (Hard Drawn)			Annealed (Soft)		
		Nominal Wall Thickness (in)	Weight (lb/ft)	Cubic ft per Linear ft	Nominal Wall Thickness (in)	Weight (lb/ft)	Cubic ft per Linear ft
1/4	0.250	--	--	--	0.030	0.081	0.00020
3/8	0.375	0.030	0.126	0.00054	0.032	0.134	0.00053
1/2	0.500	0.035	0.198	0.00101	0.032	0.182	0.00103
5/8	0.625	0.040	0.285	0.00162	0.035	0.251	0.00168
3/4	0.750	0.042	0.362	0.00242	0.042	0.362	0.00242
7/8	0.875	0.045	0.455	0.00336	0.045	0.455	0.00336
1-1/8	1.125	0.050	0.655	0.00573	0.050	0.655	0.00573
1-3/8	1.375	0.055	0.884	0.00875	0.055	0.884	0.00875
1-5/8	1.625	0.060	1.14	0.0124	0.060	1.14	0.0124

<sup>1</sup>All dimensions provided are in accordance with ASTM B280 – Standard.

<sup>2</sup>Design pressure = 551 psig.

<sup>3</sup>The Copper Tube Handbook, 2016, Copper Development Association Inc., 260 Madison Avenue, New York, NY 10016.

### Note:

- Commercially available piping often contains dust and other materials. Always blow it clean with a dry nitrogen.
- Prevent dust, water or other contaminants from entering the piping during installation.

## Copper Expansion and Contraction

Under normal operating conditions, the vapor pipe temperature of a Multi F system can vary as much as 180°F. With this large variance in pipe temperature, the designer must consider pipe expansion and contraction to avoid pipe and fitting fatigue failures.

Refrigerant pipe along with the insulation jacket form a cohesive unit that expands and contracts together. During system operation, thermal heat transfer occurs between the pipe and the surrounding insulation.

If the pipe is mounted in free air space, no natural restriction to movement is present if mounting clamps are properly spaced and installed. When the refrigerant pipe is mounted underground in a utility duct stacked among other pipes, natural restriction to linear movement is present. In extreme cases, the restrictive force of surface friction between insulating jackets could become so great that natural expansion ceases and the pipe is “fixed” in place. In this situation, opposing force caused by change in refrigerant fluid/vapor temperature can lead to pipe/fitting stress failure.

The refrigerant pipe support system must be engineered to allow free expansion to occur. When a segment of pipe is mounted between two fixed points, provisions must be provided to allow pipe expansion to naturally occur. The most common method is the inclusion of expansion Loop or U-bends mounted in the horizontal plane. When expansion loops are placed in a vertical riser, the loop is to be formed in a horizontal fashion resulting in a torsional movement during expansion and contraction. Each segment of pipe has a natural fixed point where no movement occurs. This fixed point is located at the center point of the segment assuming the entire pipe is insulated in a similar fashion. The natural fixed point of the pipe segment is typically where the expansion Loop or U-bend must be. Linear pipe expansion can be calculated using the following formula:

$$LE = C \times L \times (T_r - T_a) \times 12$$

LE	=	Anticipated linear tubing expansion (in.)
C	=	Constant (For copper = $9.2 \times 10^{-6}$ in./in.°F)
L	=	Length of pipe (ft.)
$T_r$	=	Refrigerant pipe temperature (°F)
$T_a$	=	Ambient air temperature (°F)
12	=	Inches to feet conversion (12 in./ft.)

1. From the table “Linear Thermal Expansion of Copper Tubing in Inches,” find the row corresponding with the actual length of the straight pipe segment.
2. Estimate the minimum and maximum temperature of the pipe. Typical pipe temperature change ranges: High Pressure Vapor: ambient temperature to 215°F; Low Pressure Vapor: ambient to 35°F; Liquid pipe: ambient, 80°F, 110°F. Choose the two most extreme. In the column showing the minimum pipe temperature, look up the anticipated expansion distance. Do the same for the maximum pipe temperature.
3. Calculate the difference in the two expansion distance values. The result will be the anticipated change in pipe length.

### General Example:

A system is installed and the design shows that there is a 100 foot straight segment of tubing between a Y-branch and a branch distribution unit. The system operates 24 hours per day. In heating, this pipe transports hot gas vapor to the indoor units at 120°F. In cooling, the same tube is a suction line returning refrigerant vapor to the outdoor unit at 40°F. Look up the copper tubing expansion at each temperature and calculate the difference.

### Vapor Line

Transporting Hot Vapor: 100 ft. pipe at 120°F = 1.40 in.  
 Transporting Suction Vapor: 100 ft. pipe at 40°F = 0.40 in.  
 Anticipated Change in Length: 1.40 in. – 0.40 in. = 1.00 in.

### Liquid Line

The liquid temperature remains relatively the same temperature; only the direction of flow will reverse. Therefore, no significant change in length of the liquid line is anticipated.

When creating an expansion joint, the joint depth must be a minimum of two times the joint width. Although different types of expansion arrangements are available, the data for correctly sizing an expansion loop is provided in the table “Coiled Expansion Loops and Offsets (Plan View).” Use soft copper with long radius bends on longer runs or long radius elbows for shorter pipe segments. Using the anticipated linear expansion (LE) distance calculated, look up the Expansion Loop or U-bend minimum design dimensions. If other types of expansion joints are chosen, design per ASTM B-88 Standards.

# COPPER EXPANSION AND CONTRACTION

MULTI F  
MULTI F MAX

## To find the anticipated expansion value:

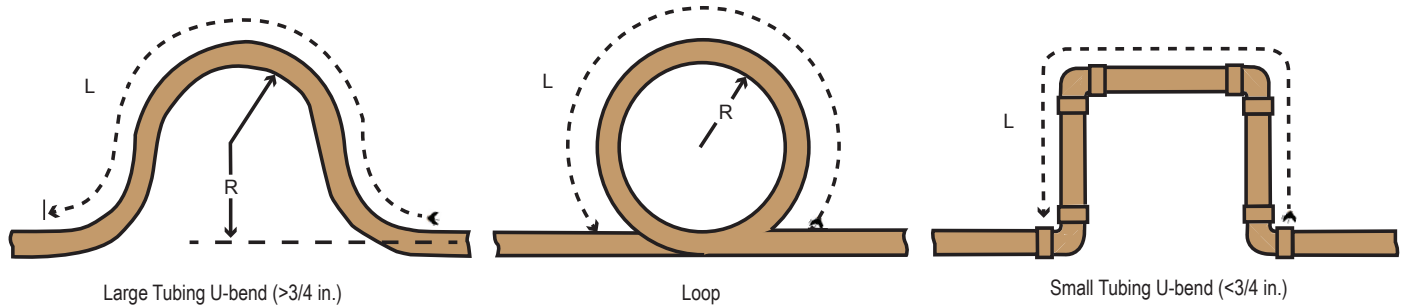
1. From the table below, find the row corresponding with the actual feet of the straight pipe segment.
2. Estimate the minimum and maximum temperature of the pipe.
3. In the column showing the minimum pipe temperature, look up the anticipated expansion distance corresponding to the segment length. Do the same for the maximum pipe temperature.
4. Calculate the difference in the two expansion distance values. The result will be the change in pipe length.

Table 19: Linear Thermal Expansion of Copper Tubing in Inches.

Pipe Length <sup>1</sup>	Fluid Temperature °F																			
	35°	40°	45°	50°	55°	60°	65°	70°	75°	80°	85°	90°	95°	100°	105°	110°	115°	120°	125°	130°
10	0.04	0.04	0.05	0.06	0.06	0.07	0.08	0.08	0.09	0.09	0.10	0.10	0.11	0.11	0.11	0.12	0.13	0.14	0.15	0.15
20	0.08	0.08	0.10	0.12	0.13	0.14	0.15	0.16	0.17	0.18	0.19	0.20	0.21	0.22	0.22	0.23	0.26	0.28	0.29	0.30
30	0.12	0.12	0.15	0.18	0.20	0.21	0.23	0.24	0.26	0.27	0.29	0.30	0.32	0.33	0.32	0.35	0.39	0.42	0.44	0.45
40	0.16	0.16	0.20	0.24	0.26	0.28	0.30	0.32	0.34	0.36	0.38	0.40	0.42	0.44	0.43	0.46	0.52	0.56	0.58	0.60
50	0.20	0.20	0.25	0.30	0.33	0.35	0.38	0.40	0.43	0.45	0.48	0.50	0.53	0.55	0.54	0.58	0.65	0.70	0.73	0.75
60	0.24	0.24	0.30	0.36	0.39	0.42	0.45	0.48	0.51	0.54	0.57	0.60	0.63	0.66	0.65	0.69	0.78	0.84	0.87	0.90
70	0.28	0.28	0.35	0.42	0.46	0.49	0.53	0.56	0.60	0.63	0.67	0.70	0.74	0.77	0.76	0.81	0.91	0.98	1.02	1.05
80	0.32	0.32	0.40	0.48	0.52	0.56	0.60	0.64	0.68	0.72	0.76	0.80	0.84	0.88	0.86	0.92	1.04	1.12	1.16	1.20
90	0.36	0.36	0.45	0.54	0.59	0.63	0.68	0.72	0.77	0.81	0.86	0.90	0.95	0.99	0.97	1.04	1.17	1.26	1.31	1.35
100	0.40	0.40	0.50	0.60	0.65	0.70	0.75	0.80	0.85	0.90	0.95	1.00	1.05	1.10	1.08	1.15	1.30	1.40	1.45	1.50
120	0.48	0.48	0.60	0.72	0.78	0.84	0.90	0.96	1.02	1.08	1.14	1.20	1.26	1.32	1.30	1.38	1.56	1.68	1.74	1.80
140	0.56	0.56	0.70	0.84	0.91	0.98	1.05	1.12	1.19	1.26	1.33	1.40	1.47	1.54	1.51	1.61	1.82	1.96	2.03	2.10
160	0.64	0.64	0.80	0.96	1.04	1.12	1.20	1.28	1.36	1.44	1.52	1.60	1.68	1.76	1.73	1.84	2.08	2.24	2.32	2.40
180	0.72	0.72	0.90	1.08	1.17	1.26	1.35	1.44	1.53	1.62	1.71	1.80	1.89	1.98	1.94	2.07	2.34	2.52	2.61	2.70
200	0.80	0.80	1.00	1.20	1.30	1.40	1.50	1.60	1.70	1.80	1.90	2.00	2.10	2.20	2.16	2.30	2.60	2.80	2.90	3.00
220	0.88	0.88	1.10	1.32	1.43	1.54	1.65	1.76	1.87	1.98	2.09	2.20	2.31	2.42	2.38	2.53	2.86	3.08	3.19	3.30
240	0.96	0.96	1.20	1.44	1.56	1.68	1.80	1.92	2.04	2.16	2.28	2.40	2.52	2.64	2.59	2.76	3.12	3.36	3.48	3.60
260	1.04	1.04	1.30	1.56	1.69	1.82	1.95	2.08	2.21	2.34	2.47	2.60	2.73	2.86	2.81	2.99	3.38	3.64	3.77	3.90
280	1.12	1.12	1.40	1.68	1.82	1.96	2.10	2.24	2.38	2.52	2.66	2.80	2.94	3.08	3.02	3.22	3.64	3.92	4.06	4.20
300	1.20	1.20	1.50	1.80	1.95	2.10	2.25	2.40	2.55	2.70	2.85	3.00	3.15	3.30	3.24	3.45	3.90	4.20	4.35	4.50
320	1.28	1.28	1.60	1.92	2.08	2.24	2.40	2.56	2.72	2.88	3.04	3.20	3.36	3.52	3.46	3.68	4.16	4.48	4.64	4.80
340	1.36	1.36	1.70	2.04	2.21	2.38	2.55	2.72	2.89	3.06	3.23	3.40	3.57	3.74	3.67	3.91	4.42	4.76	4.93	5.10
360	1.44	1.44	1.80	2.16	2.34	2.52	2.70	2.88	3.06	3.24	3.42	3.60	3.78	3.96	3.89	4.14	4.68	5.04	5.22	5.40
380	1.52	1.52	1.90	2.28	2.47	2.66	2.85	3.04	3.23	3.42	3.61	3.80	3.99	4.18	4.10	4.37	4.94	5.32	5.51	5.70
400	1.60	1.60	2.00	2.40	2.60	2.80	3.00	3.20	3.40	3.60	3.80	4.00	4.20	4.40	4.32	4.60	5.20	5.60	5.80	6.00
420	1.68	1.68	2.10	2.52	2.73	2.94	3.15	3.36	3.57	3.78	3.99	4.20	4.41	4.62	4.54	4.83	5.46	5.88	6.09	6.30
440	1.76	1.76	2.20	2.64	2.86	3.08	3.30	3.52	3.74	3.96	4.18	4.40	4.62	4.84	4.75	5.06	5.72	6.16	6.38	6.60
460	1.84	1.84	2.30	2.76	2.99	3.22	3.45	3.68	3.91	4.14	4.37	4.60	4.83	5.06	4.97	5.29	5.98	6.44	6.67	6.90
480	1.92	1.92	2.40	2.88	3.12	3.36	3.60	3.84	4.08	4.32	4.56	4.80	5.04	5.28	5.18	5.52	6.24	6.72	6.96	7.20
500	2.00	2.00	2.50	3.00	3.25	3.50	3.75	4.00	4.25	4.50	4.75	5.00	5.25	5.50	5.40	5.75	6.50	7.00	7.25	7.50

<sup>1</sup>Pipe length baseline temperature = 0°F. "Expansion of Carbon, Copper and Stainless Steel Pipe," *The Engineers' Toolbox*, [www.engineeringtoolbox.com](http://www.engineeringtoolbox.com).

Figure 28: Coiled Expansion Loops and Offsets (Plan View).



**Note:**

All expansion loops and offsets must be installed in the horizontal plane to prevent the possibility of trapping oil. Loops and offsets in vertical risers must also be installed in a horizontal plane.

Table 20: Radii of Coiled Expansion Loops and Developed Lengths of Expansion Offsets.

Anticipated Linear Expansion (LE) (in.)		Nominal Tube Size (OD) inches						
		1/4	3/8	1/2	3/4	1	1-1/4	1-1/2
1/2	R <sup>1</sup>	6	7	8	9	11	12	13
	L <sup>2</sup>	38	44	50	59	67	74	80
1	R <sup>1</sup>	9	10	11	13	15	17	18
	L <sup>2</sup>	54	63	70	83	94	104	113
1-1/2	R <sup>1</sup>	11	12	14	16	18	20	22
	L <sup>2</sup>	66	77	86	101	115	127	138
2	R <sup>1</sup>	12	14	16	19	21	23	25
	L <sup>2</sup>	77	89	99	117	133	147	160
2-1/2	R <sup>1</sup>	14	16	18	21	24	26	29
	L <sup>2</sup>	86	99	111	131	149	165	179
3	R <sup>1</sup>	15	17	19	23	26	29	31
	L <sup>2</sup>	94	109	122	143	163	180	196
3-1/2	R <sup>1</sup>	16	19	21	25	28	31	34
	L <sup>2</sup>	102	117	131	155	176	195	212
4	R <sup>1</sup>	17	20	22	26	30	33	36
	L <sup>2</sup>	109	126	140	166	188	208	226

<sup>1</sup>R = Centerline Length of Pipe.

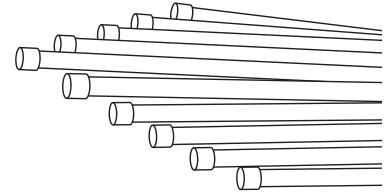
<sup>2</sup>L = Centerline Minimum Radius (inches).

## Piping Handling

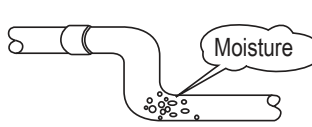
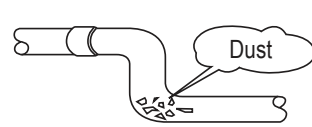
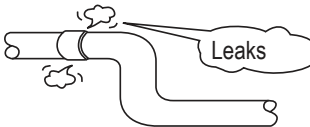
Pipes used for the refrigerant piping system must include the specified thickness, and the interior must be clean.

While handling and storing, do not bend or damage the pipes, and take care not to contaminate the interior with dust, moisture, etc.

Keep Pipes Capped While Storing.



Keep refrigerant pipe dry, clean, and airtight.

	Dry	Clean	Airtight
	No moisture should be inside the piping. 	No dust should be inside the piping. 	No leaks should occur. 
<b>Possible Problems</b>	<ul style="list-style-type: none"> <li>- Significant hydrolysis of refrigerant oil.</li> <li>- Refrigerant oil degradation.</li> <li>- Poor insulation of the compressor.</li> <li>- System does not operate properly.</li> <li>- EEVs, capillary tubes are clogged.</li> </ul>	<ul style="list-style-type: none"> <li>- Refrigerant oil degradation.</li> <li>- Poor insulation of the compressor.</li> <li>- System does not operate properly.</li> <li>- EEVs and capillary tubes become clogged.</li> </ul>	<ul style="list-style-type: none"> <li>- Refrigerant gas leaks / shortages.</li> <li>- Refrigerant oil degradation.</li> <li>- Poor insulation of the compressor.</li> <li>- System does not operate properly.</li> </ul>
<b>Solutions</b>	<ul style="list-style-type: none"> <li>- Remove moisture from the piping.</li> <li>- Piping ends should remain capped until connections are complete.</li> <li>- Do not install piping on a rainy day.</li> <li>- Connect piping properly at the unit's side.</li> <li>- Remove caps only after the piping is cut, the burrs are removed, and after passing the piping through the walls.</li> <li>- Evacuate system to a maximum of 500 microns and insure the vacuum holds at that level for 1 hour.</li> </ul>	<ul style="list-style-type: none"> <li>- Remove dust from the piping.</li> <li>- Piping ends should remain capped until connections are complete.</li> <li>- Connect piping properly at the side of the unit.</li> <li>- Remove caps only after the piping is cut and burrs are removed.</li> <li>- Retain the cap on the piping when passing it through walls, etc.</li> </ul>	<ul style="list-style-type: none"> <li>- Test system for air tightness.</li> <li>- Perform brazing procedures that comply with all applicable standards.</li> <li>- Perform flaring procedures that comply with all applicable standards.</li> <li>- Perform flanging procedures that comply with all applicable standards.</li> <li>- Ensure that refrigerant lines are pressure tested to 550 psig and hold for 24 hours.</li> </ul>



Proper system operation depends on the installer using utmost care while assembling the piping system. The following pages are an overview of best practices when installing the refrigerant piping system.

**Note:**

*LG Electronics U.S.A., Inc., is not responsible for any piping calculations, refrigerant leaks, degradation of performance, any other potential problems or damages caused by the interconnecting piping, their joint connections, isolation valves, or introduced debris inside the piping system.*

### ⊘ No Pipe Size Substitutions

Use only the pipe size selected by the LATS HVAC pipe system design software. Using a different size is prohibited and will result in a system malfunction or failure to work at all.

### ⊘ No In-line Refrigeration Components

Components such as oil traps, solenoid valves, filter-driers, sight glasses, tee fittings, and other after-market accessories are ⊘ not permitted on the refrigerant piping system between the outdoor units and the indoor / heat recovery units. LG HVAC systems are provided with redundant systems that make sure oil is properly returned to the compressor. Sight-glasses and solenoid valves will cause vapor to form in the liquid stream. Over time, driers will deteriorate and introduce debris into the system. The designer and installer must verify the refrigerant piping system is free of traps, sagging pipes, sight glasses, filter driers, etc.

### Field-Provided Isolation Ball Valves

LG maintains a neutral position on using isolation valves in LG HVAC refrigerant piping systems. LG does not endorse any manufacturer of isolation valves. It is recognized that installing isolation valves will simplify future maintenance requirements, and, if used, considerations must be taken including, but not limited to, the following:

- Pressure drops for any component used, including isolation valves, must be known in equivalent pipe length and calculated into the total and segment equivalent piping lengths and compared to product design limitations.
- In all cases, materials must be suitable for the application and any applicable codes, including, but not limited to, diameter and wall thickness continuity per ACR standards.

Failure to do so will cause significant performance degradation. Proper leak checks must be performed. Using isolation valves does not automatically void any LG product warranty, however, a limited warranty will be voided in whole or part must any field supplied accessory fail in any way that causes product failure.

### Using Elbows

Field-supplied elbows are allowed if they are long radius and designed for use with R410A refrigerant. The designer and installer, however, must be cautious with the quantity and size of fittings used, and must account for the additional pressure losses in equivalent pipe length calculation for each branch. The equivalent pipe length of each elbow must be added to each pipe segment in the LATS program.

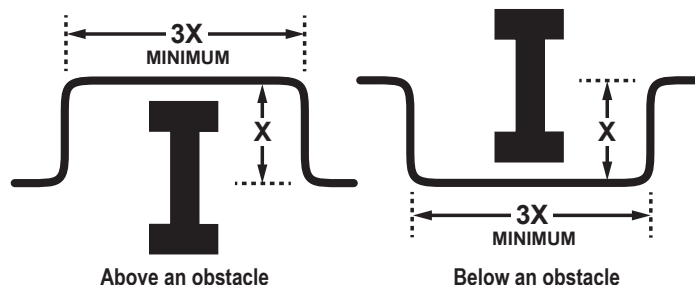
### Pipe Bends

When bending soft copper, use long radius bends. Refer to the “Radii of Coiled Expansion Loops and Developed Lengths of Expansion Offsets” table for minimum radius specifications.

## Obstacles


When an obstacle, such as an I-beam or concrete T, is in the path of the planned refrigerant pipe run, it is best practice to route the pipe over the obstacle. If adequate space is not available to route the insulated pipe over the obstacle, then route the pipe under the obstacle. In either case, it is imperative the length of the horizontal section of pipe above or below the obstacle be a minimum of three (3) times the longest vertical rise (or fall) at either end of the segment.

Figure 29: Installing Piping Above and Below an Obstacle.



## Pipe Supports

A properly installed pipe system must be adequately supported to avoid pipe sagging. Sagging pipes become oil traps that lead to equipment malfunction.

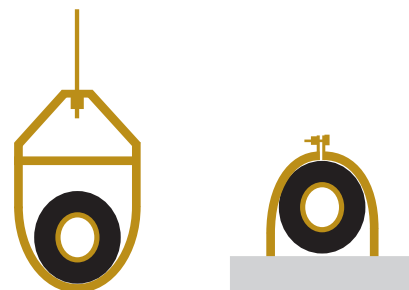
Pipe supports must  never touch the pipe wall; supports must be installed outside (around) the primary pipe insulation jacket. Insulate the pipe first because pipe supports must be installed outside (around) the primary pipe insulation jacket. Clevis hangers must be used with shields between the hangers and insulation. Field provided pipe supports must be designed to meet local codes. If allowed by code, use fiber straps or split-ring hangers suspended from the ceiling on all-thread rods (fiber straps or split ring hangers can be used as long as they do not compress the pipe insulation). Place a second layer of insulation over the pipe insulation jacket to prevent chafing and compression of the primary insulation in the confines of the support clamp.

A properly installed pipe system will have sufficient supports to avoid pipes from sagging during the life of the system. As necessary, place supports closer for segments where potential sagging could occur. Maximum spacing of pipe supports must meet local codes. If local codes do not specify pipe support spacing, pipe must be supported:

- Maximum of five (5) feet on center for straight segments of pipe up to 3/4 inches outside diameter size.
- Maximum of six (6) feet on center for pipe up to one (1) inch outside diameter size.
- Maximum of eight (8) feet on center for pipe up to two (2) inches outside diameter size.

Wherever the pipe changes direction, place a hanger within twelve (12) inches on one side and within twelve (12) to nineteen (19) inches of the bend on the other side. Support piping at indoor units, Y-branch, and Header fittings as shown.

Figure 30: Pipe Hanger Details.



### Note:

Use a 4" + long sheet curved sheet metal saddles between hanger bracket and insulation to promote linear expansion/contraction.

Figure 31: Typical Pipe Support Location—Change in Pipe Direction.

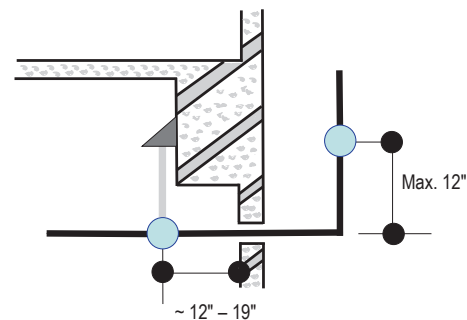


Figure 32: Pipe Support at Indoor Unit.

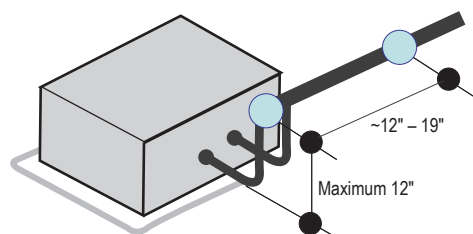


Figure 33: Pipe Support at Y-branch Fitting.

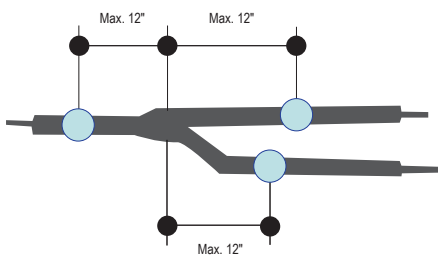
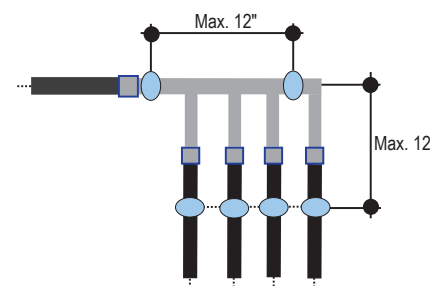


Figure 34: Pipe Support at Header Fitting.



## Examples of Supports

Figure 35: U-Bolt Support with Insulation.

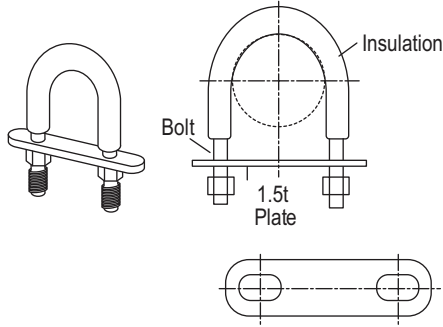


Figure 36: O-Ring Support with Insulation.

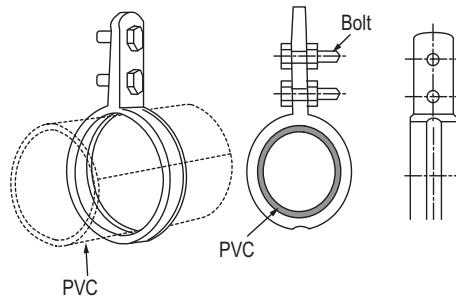
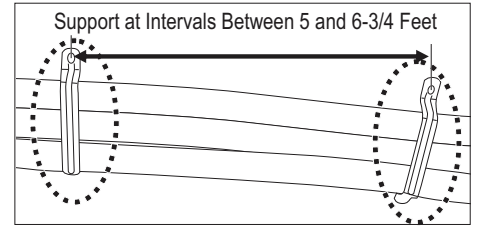


Figure 37: Saddle-Type Support.



*Do not compress the insulation with the saddle-type support. If the insulation is compressed, it will tear open and allow condensation to generate during product operation.*

Figure 38: U-Bolt Support with an Insulated Pipe.

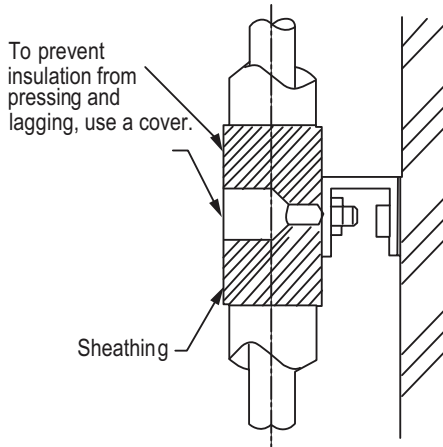


Figure 39: O-Ring Band Support with an Insulated Pipe.

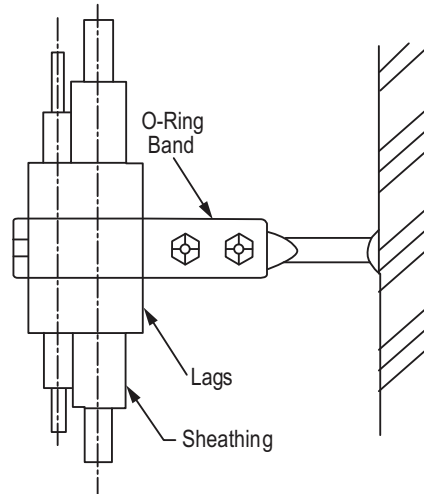


Figure 40: One-Point Down-Stop Support (>441 lbs.).

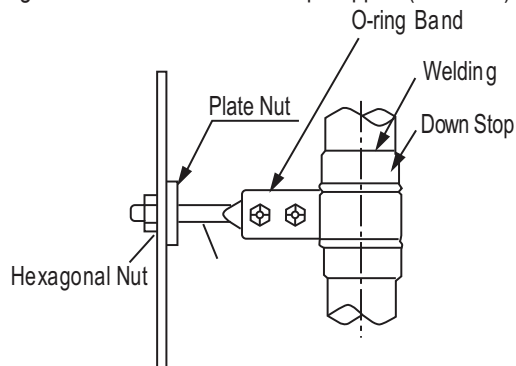
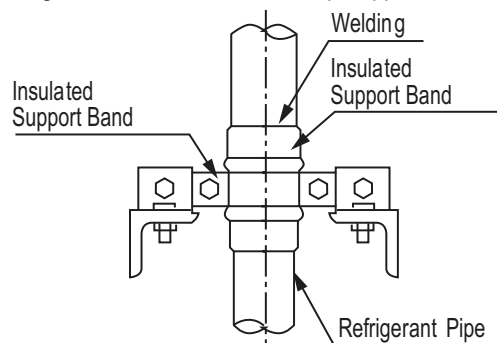


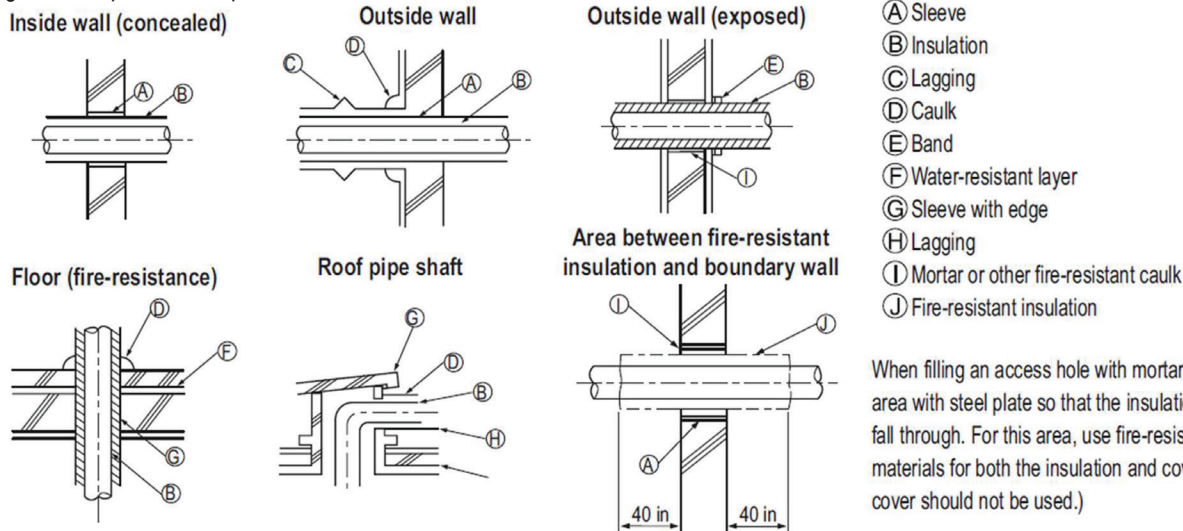
Figure 41: Two-Point Down-Stop Support.



## Pipe Sleeves at Penetrations

LG recommends that all pipe penetrations through walls, floors, and pipes buried underground be properly insulated and routed through an appropriate wall sleeve of sufficient size to prevent compression of refrigerant pipe insulation and promote free movement of the pipe within the sleeve. Use 4"+ curved sheet metal saddles between the bottom surface of the pipe and the bottom surface of the penetration.

Figure 42: Pipe Sleeve Options.



When filling an access hole with mortar, cover the area with steel plate so that the insulation will not fall through. For this area, use fire-resistant materials for both the insulation and cover. (Vinyl cover should not be used.)

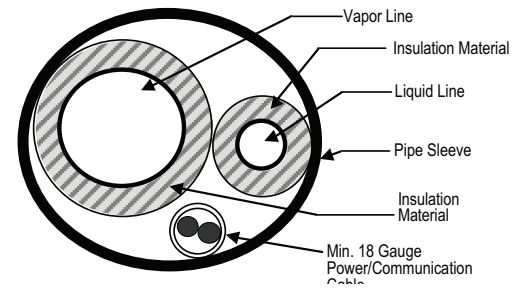
### Note:

Diameter of penetrations must be determined by pipe diameter plus the thickness of the insulation.

## Underground Refrigerant Piping

Refrigerant pipe installed underground must be routed inside a vapor tight protective sleeve to prevent insulation deterioration and water infiltration. Refrigerant pipe installed inside underground casing must be continuous without any joints. Underground refrigerant pipe must be located at a level **below the frost line**.

Figure 43: Typical Arrangement of Refrigerant Pipe and Cable(s) in a Utility Conduit.



### Note:

Provide expansion joints in long pipe segments and place in an accessible conduit box for inspection. Use galvanized curved sheet metal saddles at all mounting points. Pipe must be allowed to move freely linearly.

Table 21: Utility Conduit Sizes.

Liquid Pipe <sup>1</sup>	Vapor Pipe <sup>1</sup>			
	3/8 (2.0 <sup>2,5</sup> )	1/2 (2.0 <sup>2,5</sup> )	5/8 (2-1/8 <sup>2,5</sup> )	3/4 (2-1/4 <sup>2,5</sup> )
1/4 (1.0) <sup>3</sup>	4	4	4	4
3/8 (1-1/8) <sup>3</sup>	4	4	4	5
1/2 (1-1/2) <sup>4</sup>	5	5	5	5
5/8 (1-5/8) <sup>4</sup>	5	5	5	5
3/4 (1-3/4) <sup>4</sup>	5	5	5	5

<sup>1</sup>OD pipe diameter in inches; Values in parenthesis ( ) indicate OD of pipe with insulation jacket.

<sup>2</sup>Diameter of pipe with insulation. Thickness of pipe insulation is typical. Actual required thickness will vary based on surrounding ambient conditions and must be calculated and specified by the design engineer.

<sup>3</sup>Insulation thickness (value in parenthesis) = 3/8 inch.


<sup>4</sup>Insulation thickness (value in parenthesis) = 1 inch.

<sup>5</sup>Insulation thickness (value in parenthesis) = 3/4 inch.

## Flaring and Brazing Procedures

One of the main causes of refrigerant leaks is a defective connection. For LG HVAC systems, the installer needs to know how perform both flared and brazed connections successfully.

### Note:

- During installation, it is imperative to keep the piping system free of contaminants and debris such as copper burrs, slag, or carbon dust.
-  Do not use kinked pipe caused by excessive bending in one specific area on its length.

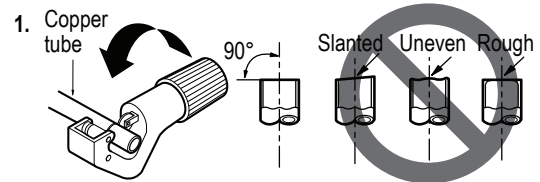
## Flaring Procedure

### Note:

When selecting flare fittings, always use a 45° fitting rated for use with high pressure refrigerant R410A. Selected fittings must also comply with local, state, or federal standards.

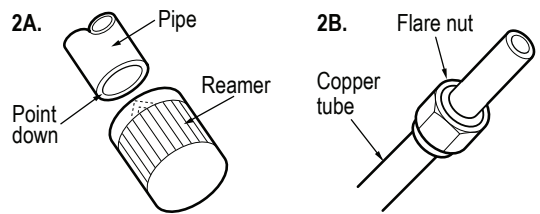
#### 1. Cut the pipe to length.

- Measure the distance between the indoor unit and the outdoor unit.
- Cut the pipes a little longer than measured distance.



#### 2A. Remove the burrs.

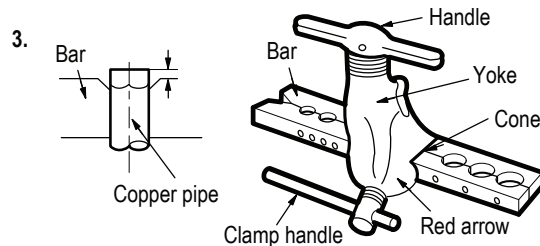
- Completely remove all burrs from pipe ends.
- When removing burrs, point the end of the copper pipe down to avoid introducing foreign materials in the pipe.



#### 2B. Slide the flare nut onto the copper tube.

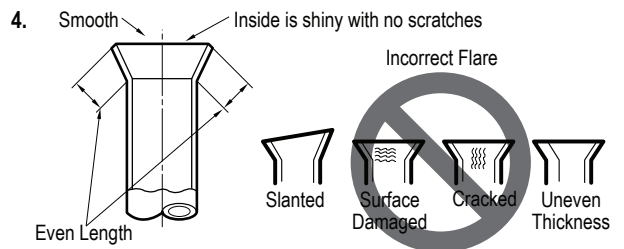
#### 3. Flaring the pipe end.

- Use the proper size flaring tool to finish flared connections as shown.
- ALWAYS create a 45° flare when working with R410A.

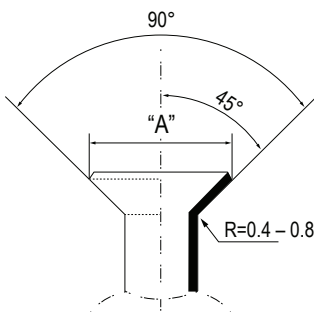


#### 4. Carefully inspect the flared pipe end.

- Compare the geometry with the figure to the right
- If the flare is defective, cut it off and re-do procedure.
- If flare looks good, blow the pipe clean with dry nitrogen.



Dimensions of the Flare.



Flared Connection Dimensions / Tightening Torque.

Pipe Size (in. O.D.)	Outside Diameter (mm)	"A" Dimension (mm [in.])
1/4	6.35	~ 9.1 (11/32 - 23/64)
3/8	9.52	~ 13.2 (1/2 - 33/64)
1/2	12.7	~ 16.6 (41/64 - 21/32)
5/8	15.88	~ 19.7 (49/64 - 25/32)
3/4	19.05	-

## Tightening the Flare Nuts

Tightening Torque for Flare Nuts.

Pipe Size (in. O.D.)	Outside Diameter (mm)	Tightening Torque (ft-lbs.)
1/4	6.35	13.0 - 18.0
3/8	9.52	24.6 - 30.4
1/2	12.7	39.8 - 47.7
5/8	15.88	45.4 - 59.3
3/4	19.05	71.5 - 87.5

1. When connecting the flare nuts, coat the flare (outside only) with polyvinyl ether (PVE) refrigeration oil only.

### Note:

⊘ Do not use polyolyester (POE) or any other type of mineral oil as a thread lubricant. These lubricants are not compatible with the PVE oil used in this system and create oil sludge leading to equipment damage and system malfunction.

⊘ Do not add any contaminants inside the refrigerant piping.

2. Initially hand tighten the flare nuts using three (3) or four (4) turns.
3. To finish tightening the flare nuts, use both a torque wrench and a backup wrench.
4. After all the piping has been connected and the caps have been tightened, check for refrigerant gas leaks.

## Loosening the Flare Nuts

Always use two (2) wrenches to loosen the flare nuts.

## Brazing Procedure

### ⚠ WARNING

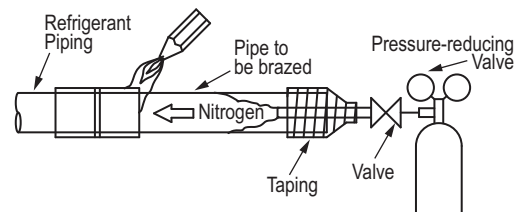
⊘ Do not braze in an enclosed location. ⊘ Do not allow the refrigerant to leak during brazing. Always test for gas leaks before and after brazing. If the refrigerant combusts, it generates a toxic gas that will cause physical injury or death.

### Note:

Braze the pipes to the service valve pipe stub of the outdoor unit.

1. All joints are brazed in the field. LG HVAC refrigeration system components contain very small capillary tubes, small orifices, electronic expansion valves, oil separators, and heat exchangers that can easily become blocked. Proper system operation depends on the installer using best practices and utmost care while assembling the piping system.
2. Store pipe stock in a dry place; keep stored pipe capped and clean.
3. Blow clean all pipe sections with dry nitrogen prior to assembly.
4. Use adapters to assemble different sizes of pipe.
5. Always use a non-oxidizing material for brazing. ⊘ Do not use flux, soft solder, or anti-oxidant agents. If the proper material is not used, oxidized film will accumulate and clog or damage the compressors. Flux can harm the copper piping or refrigerant oil.
6. Use a tubing cutter, ⊘ do not use a saw to cut pipe. De-bur and clean all cuts before assembly.
7. Brazing joints:
  - Use a dry nitrogen purge operating at a minimum pressure of three (3) psig and maintain a steady flow.
  - Use a 15% silver phosphorous copper brazing alloy to avoid overheating and produce good flow.
  - Protect isolation valves, electronic expansion valves, and other heat-sensitive control components from excessive heat with a wet rag or heat barrier spray.

Figure 44: Refrigerant Pipe Brazing.





## Multi F Outdoor Unit to Indoor Unit Piping Connections

### Note:

- ⊘ **Avoid Pipe Damage**
  - When routing field-provided piping, ⊘ avoid damaging the outdoor unit from excessive vibration.
  - Properly insulate the liquid and gas lines separately up to the point of connection at the unit frame.
  - See table below for Multi F outdoor unit connection types.
  
- ⊘ Correctly route the piping so it does not make contact with mounting bolts. Allow room for field installation.

Figure 45: Multi F Refrigerant Pipe Connections (LMU36CHV shown as example).

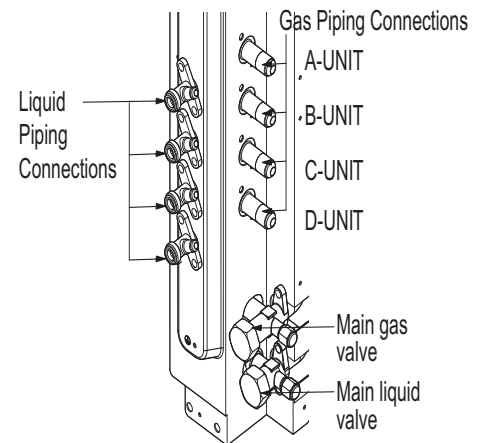


Table 22: Outdoor Unit Piping Connections.

Outdoor Unit Piping Connections	LMU18*HV	LMU24*HV	LMU30CHV	LMU36CHV
Liquid Line Connection (in., OD) x Qty.	1/4 x 2	1/4 x 3	1/4 x 4	1/4 x 4
Vapor Line Connection (in., OD) x Qty.	3/8 x 2	3/8 x 3	3/8 x 4	3/8 x 4

Table 23: Indoor Unit Pipe Sizes.

Indoor Unit Capacity	Vapor Line Piping Size (in., OD)	Liquid Line Piping Size (in., OD)
7,000 Btu/h	Ø3/8	Ø1/4
9,000 Btu/h		
12,000 Btu/h		
15,000 Btu/h		
15,000 Btu/h: Console; 18,000 Btu/h	Ø1/2	
24,000 Btu/h		

Table 24: Indoor Unit Piping Connections.

Indoor Unit Capacity	Vapor Line Conn. (in., OD)	Liquid Line Conn. (in., OD)
7,000 Btu/h	Ø3/8	Ø1/4
9,000 Btu/h		
12,000 Btu/h		
15,000 Btu/h		
18,000 Btu/h: Wall-Mounted	Ø5/8	Ø3/8
15,000 Btu/h: Console; 18,000 Btu/h: Low Static Duct, Four-Way Cassette, VAHU	Ø1/2	Ø1/4
24,000 Btu/h	Ø1/2	Ø1/4

### Note:

Connection sockets (included as a factory-supplied accessory with the indoor units) will need to be used when piping the indoor units to the outdoor unit. See tables above and below for indoor unit piping connection and connection socket dimensions. If a 36K indoor unit is included, the connection sockets are included with the Branch Distribution unit.

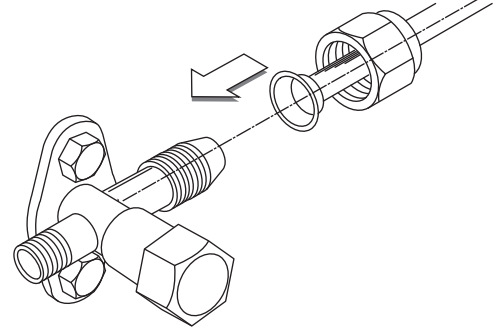
Table 25: Connection Socket Dimensions.

Indoor Unit Capacity	Vapor (in., OD)		Liquid (in., OD)	
	A	B	A	B
18,000 Btu/h: Wall-Mounted	Ø3/8 → Ø1/2, Ø1/2 → Ø5/8		Ø1/4 → Ø3/8	
15,000 Btu/h: Console; 18,000 Btu/h: Low Static Duct, Four-Way Cassette, VAHU	Ø3/8 → Ø1/2		N/A	
24,000 Btu/h	Ø3/8 → Ø1/2		N/A	

## Installing Field Piping to the Outdoor Unit Piping Connections

1. Verify the outdoor unit service ports are closed.
2. Remove the caps on the outdoor unit piping connections.
3. Connect the gas piping first to ROOM A, then to ROOM B, then to ROOM C, in that order. Number of connections will differ depending on outdoor unit.
4. Tighten each gas piping connection individually following the "Tightening the Flare Nuts" procedure below.
5. Connect the liquid piping first to ROOM A, then to ROOM B, then to ROOM C, in that order. Number of connections will differ depending on outdoor unit.
6. Tighten each liquid piping connection individually following the "Tightening the Flare Nuts" procedure below.

Figure 46: Close Up of the Field Piping to the Outdoor Unit Piping Connection.



## Tightening the Flare Nuts

Tightening Torque for Flare Nuts.

Pipe Size (in. O.D.)	Outside Diameter (mm)	Tightening Torque (ft.-lbs.)
1/4	6.35	13.0 - 18.0
3/8	9.52	24.6 - 30.4
1/2	12.7	39.8 - 47.7
5/8	15.88	45.4 - 59.3
3/4	19.05	71.5 - 87.5

1. When connecting the flare nuts, coat the flare (outside only) with polyvinyl ether (PVE) refrigeration oil only.

## Note:

- ⊘ Do not use polyolyester (POE) or any other type of mineral oil as a thread lubricant. These lubricants are not compatible with the PVE oil used in this system and create oil sludge leading to equipment damage and system malfunction.
  - ⊘ Do not add any contaminants inside the refrigerant piping.
2. Initially hand tighten the flare nuts using three (3) or four (4) turns.
  3. To finish tightening the flare nuts, use both a torque wrench and a backup wrench.
  4. After all the piping has been connected and the caps have been tightened, check for refrigerant gas leaks.

## Using the Connection Socket

Some indoor units require the use of a connection socket when piping the indoor units to the outdoor unit. (See previous page for information.) The connection sockets are included as a factory-supplied accessory with the indoor units. To install:

1. Align the center of the piping sections as seen in the diagrams at right and below.
2. Follow the "Tightening the Flare Nuts" procedure above.

Figure 47: Connection Socket Diagram, External View.

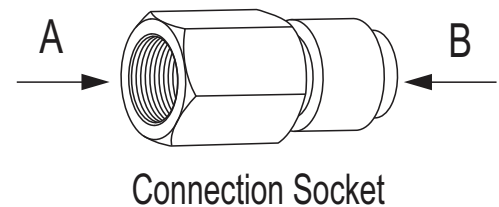


Figure 48: Connection Socket Diagram.

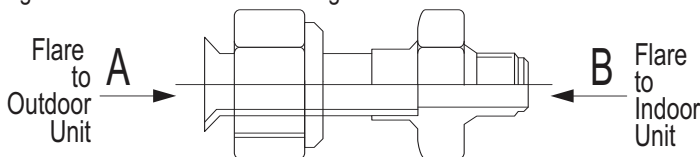
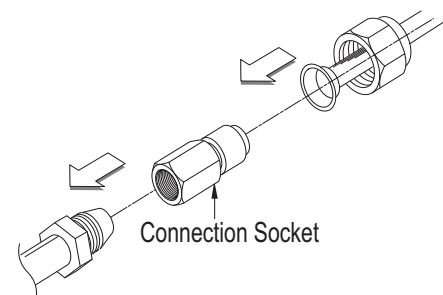


Figure 49: Performing Connections.

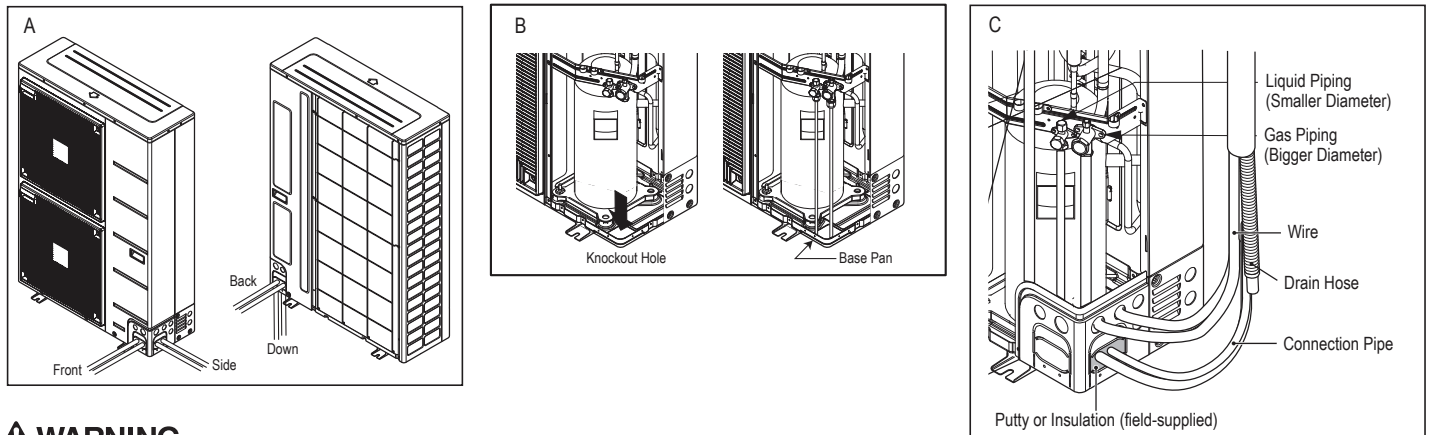


## Multi F MAX Refrigerant Piping Connections / Piping Routes

For Multi F MAX outdoor units, piping can be installed in one of four directions: front, side, back, and down (A). If the downward installation is chosen, the knockout hole in the base pan must be accessed (B).

Whatever direction is chosen, plug the access holes with field-provided putty or insulation to fill all gaps (C).

Figure 50: Multi F MAX Piping Installation.



### ⚠ WARNING

Insects or small animals entering the outdoor unit will cause a short circuit in the electrical box, which will lead to fire, electric shock, physical injury, or death.

### Note:

Insects or small animals entering the outdoor unit will cause a short circuit in the electrical box, which will lead to unit failure.

## Multi F MAX Outdoor Unit System Piping Connections

### Note:

#### ⊘ Avoid Pipe Damage

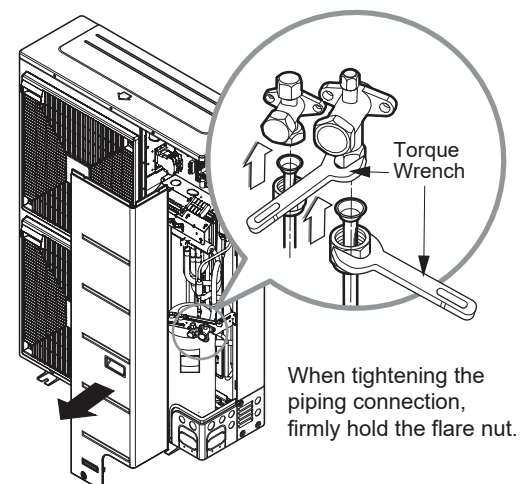
- When routing field-provided piping, ⊘ avoid damaging the outdoor unit from excessive vibration.
- Properly insulate the liquid and gas lines separately up to the point of connection at the unit frame.
- See table below for Multi F MAX outdoor unit connection types.

⊘ Correctly route the piping so it does not make contact with mounting bolts. Allow room for field installation.

Table 26: Multi F MAX Outdoor Unit Piping Connections.

Outdoor Unit Piping Connections	LMU480HV, LMU540HV, LMU600HV
Liquid Line Connection (in., OD) x Qty.	Ø3/8 x 1
Vapor Line Connection (in., OD) x Qty.	Ø3/4 x 1

Figure 51: Multi F MAX Outdoor Unit Refrigerant Pipe Connections.



## Branch Distribution to Indoor Unit Piping Connections

- Install indoor unit liquid and vapor refrigerant pipes (and connection wiring) to the appropriate branch distribution ports.
- Clearly note on the indoor unit's refrigerant piping (liquid, vapor) which branch distribution port it is connected to (A, B, C, D).

Table 27: Branch Distribution Unit Piping Connections.

Branch Distribution Unit	Refrigerant Connections Pipe Size (in.)		Connectible Indoor Unit Capacity (Btu/h)
	Liquid	Vapor	
PMBD3620	Ø1/4 x 2	Ø3/8 x 2	7,000, 9,000, 12,000, 15,000, 18,000, 24,000
PMBD3630	Ø1/4 x 3	Ø3/8 x 3	7,000, 9,000, 12,000, 15,000, 18,000, 24,000
PMBD3640	Ø1/4 x 4	Ø3/8 x 4	7,000, 9,000, 12,000, 15,000, 18,000, 24,000
PMBD3641	Ø1/4 x 4	Ø3/8 x 3	7,000, 9,000, 12,000, 15,000, 18,000, 24,000 (A, B, C)
		Ø1/2 x 1	24,000, 36,000 (D)

Figure 53: Branch Distribution Ports to Indoor Units -- Side View.

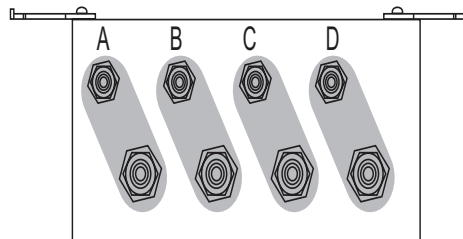


Table 28: Indoor Unit Pipe Sizes.

Indoor Unit Capacity	Vapor Line Piping Size (in., OD)	Liquid Line Piping Size (in., OD)
7,000 Btu/h	Ø3/8	Ø1/4
9,000 Btu/h		
12,000 Btu/h		
15,000 Btu/h		
15,000 Btu/h: Console; 18,000 Btu/h	Ø1/2	Ø3/8
24,000 Btu/h		
36,000 Btu/h	Ø5/8	Ø3/8

### Note:

Connection sockets (included as a factory-supplied accessory with the indoor units) will need to be used when piping the indoor units to the branch distribution unit. The connection sockets for 36k indoor units are factory supplied with the branch distribution units. See tables above and below for indoor unit piping connection and connection socket dimensions. See the follow page for the connection socket installation procedure.

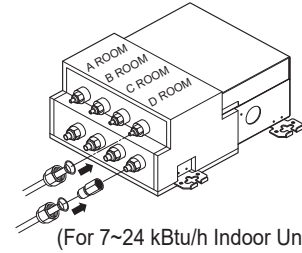
Table 30: Connection Socket Dimensions.

Indoor Unit Capacity	Vapor (in., OD)		Liquid (in., OD)	
	A	B	A	B
18,000 Btu/h: Wall-Mounted	Ø3/8 → Ø1/2	Ø1/2 → Ø5/8	Ø1/4 → Ø3/8	
15,000 Btu/h: Console; 18,000 Btu/h: Low Static Duct, Four-Way Cassette, VAHU	Ø3/8 → Ø1/2		N/A	
24,000 Btu/h*	Ø3/8 → Ø1/2		N/A	
36,000 Btu/h	Ø1/2 → Ø5/8		Ø1/4 → Ø3/8	

\*No socket adapter is required if connected to Port D on the PMBD3641.

Figure 52: Branch Distribution Piping Connections.

Multi F MAX Outdoor Units  
(48, 54, 60 kBtu/h)  
(Branch Distribution Unit: PMBD3640)



(Branch Distribution Unit: PMBD3641)

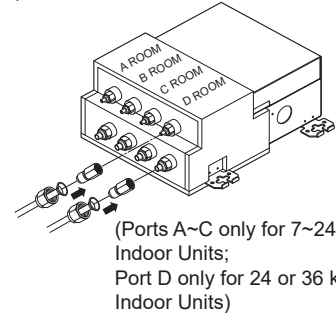


Table 29: Indoor Unit Piping Connections.

Indoor Unit Capacity	Vapor Line Conn. (in., OD)	Liquid Line Conn. (in., OD)
7,000 Btu/h	Ø3/8	Ø1/4
9,000 Btu/h		
12,000 Btu/h		
15,000 Btu/h		
18,000 Btu/h: Wall-Mounted	Ø5/8	Ø3/8
15,000 Btu/h: Console; 18,000 Btu/h: Low Static Duct, Four-Way Cassette, VAHU	Ø1/2	Ø1/4
24,000 Btu/h		
36,000 Btu/h	Ø5/8	Ø3/8

## Installing Field Piping to the Branch Distribution Unit Piping Connections

1. Remove any caps, etc., that could be on the branch distribution unit.
2. Tighten each piping connection individually following the “Tightening the Flare Nuts” procedure below.
3. When all piping installation has been completed, perform the triple leak / pressure and evacuation tests (see the Final Installation Procedures Section), verify that the system does not have any leaks, and then fully insulate all joints / connections.

## Using the Connection Socket

Some indoor units require the use of a connection socket when piping the indoor units to the branch distribution unit. (See previous page and below for information.) The connection sockets are included as a factory-supplied accessory with the indoor units, or in the case of the 36k indoor unit, it is factory supplied with the branch distribution units. To install:

1. Remove any caps, etc., that could be on the branch distribution unit.
2. Align the center of the piping sections as seen in the diagram at right.
3. Tighten each piping connection individually following the “Tightening the Flare Nuts” procedure below.
4. When all piping installation has been completed, perform the triple leak / pressure and evacuation tests (see the Final Installation Procedures Section), verify that the system does not have any leaks, and then fully insulate all joints / connections.

Figure 54: Connection Socket Diagram, External View.

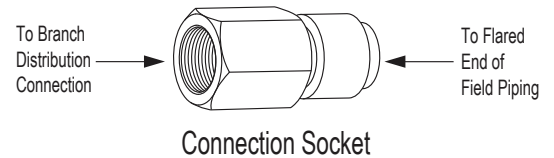
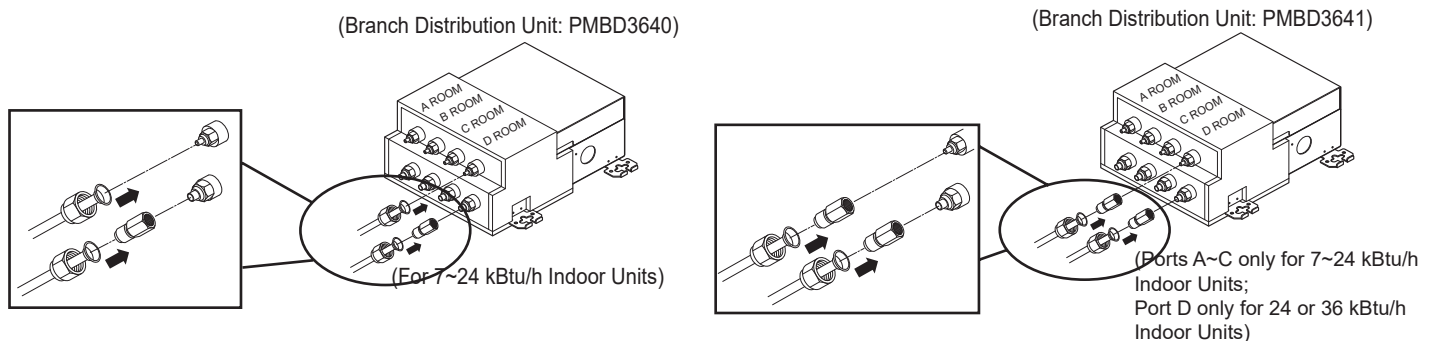


Figure 55: Close Up of Branch Distribution to Indoor Unit Piping Connections.



## Tightening the Flare Nuts

Tightening Torque for Flare Nuts.

Pipe Size (in. O.D.)	Outside Diameter (mm)	Tightening Torque (ft-lbs.)
1/4	6.35	13.0 - 18.0
3/8	9.52	24.6 - 30.4
1/2	12.7	39.8 - 47.7
5/8	15.88	45.4 - 59.3
3/4	19.05	71.5 - 87.5

1. When connecting the flare nuts, coat the flare (outside only) with polyvinyl ether (PVE) refrigeration oil only.

## Note:

- ⊘ Do not use polyolyester (POE) or any other type of mineral oil as a thread lubricant. These lubricants are not compatible with the PVE oil used in this system and create oil sludge leading to equipment damage and system malfunction.
- ⊘ Do not add any contaminants inside the refrigerant piping.

2. Initially hand tighten the flare nuts using three (3) or four (4) turns.
3. To finish tightening the flare nuts, use both a torque wrench and a backup wrench.
4. After all the piping has been connected and the caps have been tightened, check for refrigerant gas leaks.

Figure 56: Socket Connection.

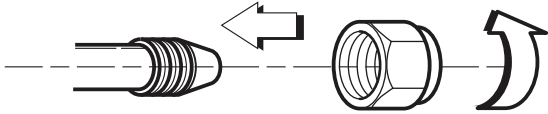
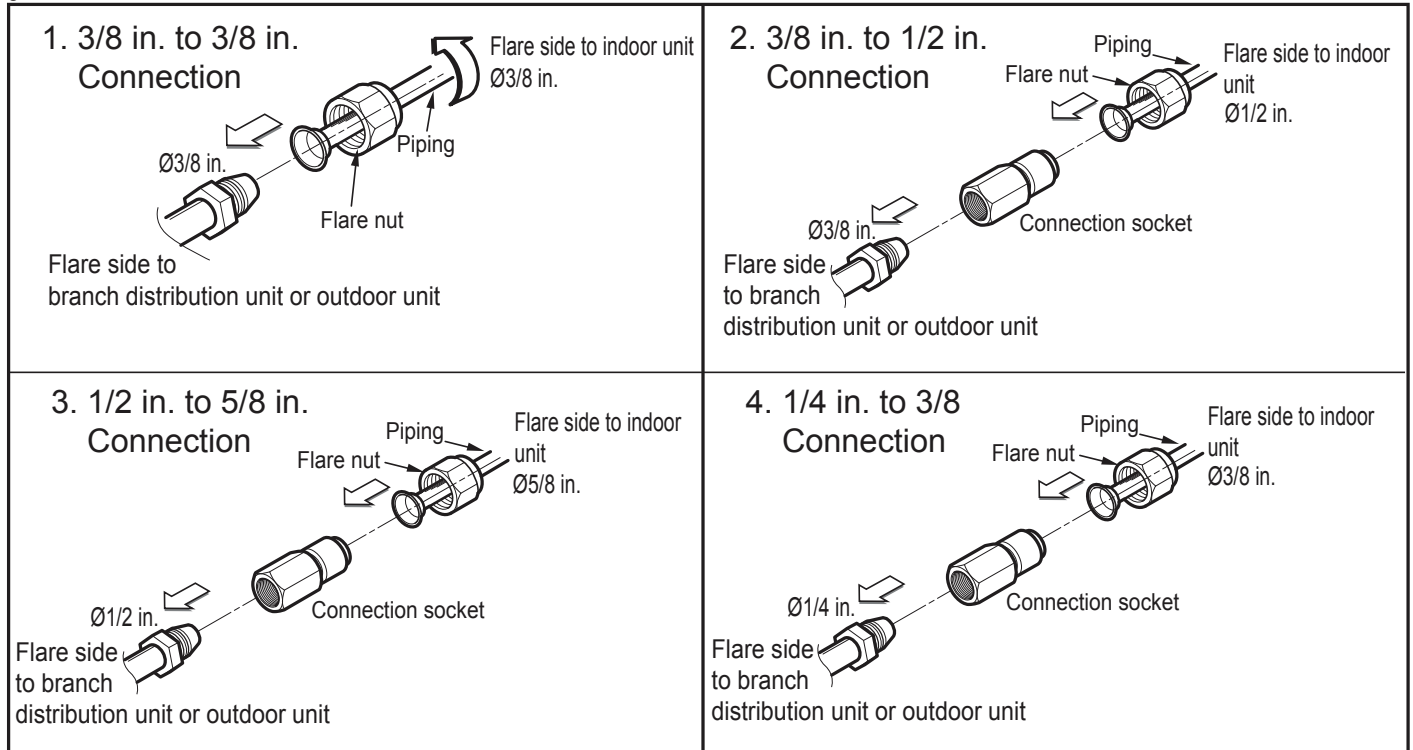


Figure 57: Possible Outdoor Unit or Branch Distribution Unit to Indoor Unit Connections.





## Multi F MAX Y-Branch Kit PMBL5620

The LG-supplied Y-Branch kit PMBL5620 MUST be used when installing two (2) branch distribution units in parallel on one (1) Multi F MAX system. ⚠ Field-supplied fittings are not permitted. Each Y-Branch kit includes two (2) Y-branches (one for the liquid line and one for the vapor line) and insulation covers.

Y-branches can be installed in horizontal or vertical configurations. When installed vertically, position the Y-branch so the straight through leg is  $\pm 3^\circ$  of plumb. When installed horizontally, position the Y-branch so the take-off leg is level and shares the same horizontal plane as the straight-through leg  $\pm 5^\circ$  rotation.

Y-branches must be properly installed following instructions in the applicable LG manual. Y-branches must always be installed with the single port facing the outdoor unit and the two-port end facing the branch distribution units. ⚠ Do not install Y-branches backwards as refrigerant flow cannot make U-turns. The Y-branch kit must be located at least three (3) feet from the outdoor unit. Provide a minimum of 20 inches between a Y-branch and the branch distribution unit.

When a Y-branch is located in a pipe chase or other concealed space, access doors must be provided for inspection access.

The equivalent pipe length of each Y-branch (1.6') must be added to the main pipe segment entered into LATS piping design software.

### Note:

- Design pressure is 551 psig.
- All dimensions in inches. Tolerance  $\pm 1/4$  inch.
- Images are not to scale.

Figure 60: Horizontal Configuration End View.

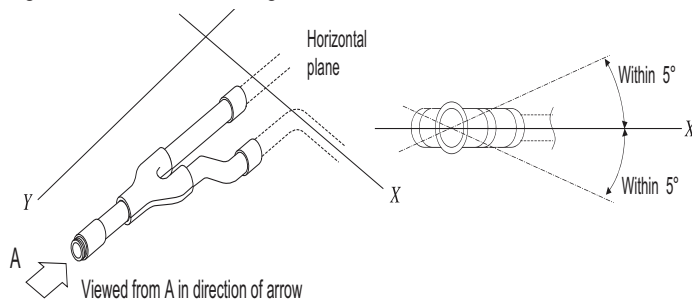


Figure 58: Y-Branch Port Identifier Diagram.

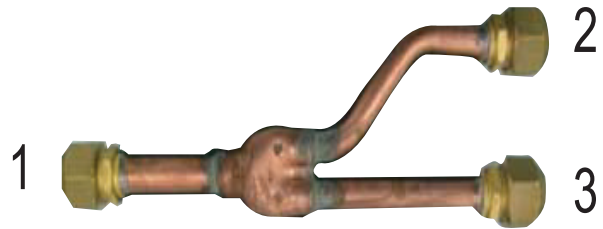
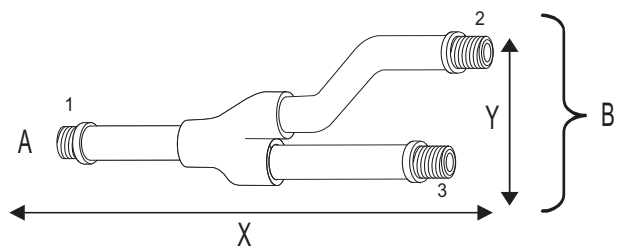


Figure 59: Y-Branch Dimensions Diagram.



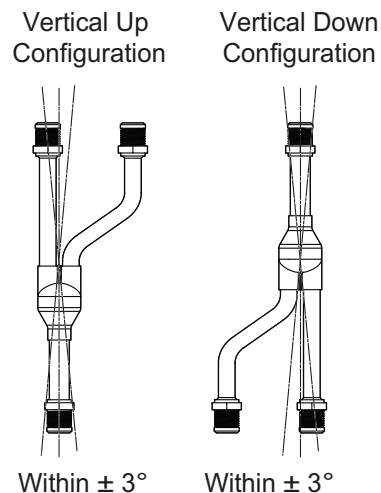
A = To Outdoor Unit

B = To Branch Distribution Unit

Table 31: Y-Branch Connection Diameters.

Model	Y-Branch Type	Port Identifier (inch)			Dimensions	
		1	2	3	X	Y
PMBL5620	Liquid	3/8	3/8	3/8	13.80	3.24
	Vapor	3/4	3/4	3/4	12.48	3.02

Figure 61: Y-branch Installation Alignment Specification.



## Bundling

If a conduit or piping set cover is not used on the connection from the outdoor unit to the interior, bundle both insulated refrigerant pipes, the drain hose, and outdoor unit to indoor unit / branch distribution unit communication / connection (power) cable together with wide vinyl tape.

1. Piping must be fully encased in insulation material: Overlap the field installation piping insulation material and the indoor unit piping insulation material.
2. Bind together the two pipes, using vinyl tape. Make sure there are no gaps during the binding.
3. Be sure the cutting line is placed upward.
4. Wrap the rear piping section with narrow vinyl tape.
5. Continue to wrap the indoor unit pipe as connected to the outdoor connection pipe.
6. Using a wider vinyl tape, bundle the piping and drain hose together.
  - Tape must be sufficient to cover the piping in order to fit into the rear piping housing area at the back of the indoor unit.

## Special Applications

If an additional drain hose is necessary, the end of drain outlet must be routed above the ground. Secure the drain hose appropriately.

### When the Outdoor Unit is Installed Below the Indoor Unit:

1. Use a conduit, piping set cover, or bundle the (separately) insulated refrigerant piping, the drain hose, and the communications / connection (power) cable together.
2. Make sure to include some slack in the wiring. Wiring must be installed in an upwards direction to prevent water from accessing into the control box.
3. Secure the conduit, piping set cover, or bundle along the outside wall using saddles or a similar type of piping support.
4. Seal any openings in the wall that are around the piping.

### When the Outdoor Unit is Installed Above the Indoor Unit:

1. Use a conduit, piping set cover, or bundle the (separately) insulated refrigerant piping and the communications / connection (power) cable together up to the outdoor unit service valves.
2. Make sure to include some slack in the wiring. Wiring must be installed in upwards direction to prevent water from traveling into the control box.
3. If necessary, secure the conduit, piping set cover, or bundle along the outside wall using saddles or a similar type of piping support.
4. Ensure the insulated drain hose from the indoor unit is installed away from the outdoor unit, and in a downwards direction. If necessary, secure along the outside wall using saddles or a similar type of support.
5. Seal any openings in the wall that are around the piping.

Figure 62: Bundling the Connection Components (From Outdoor Unit to Indoor Unit / Branch Distribution Unit [Multi F MAX systems only]).

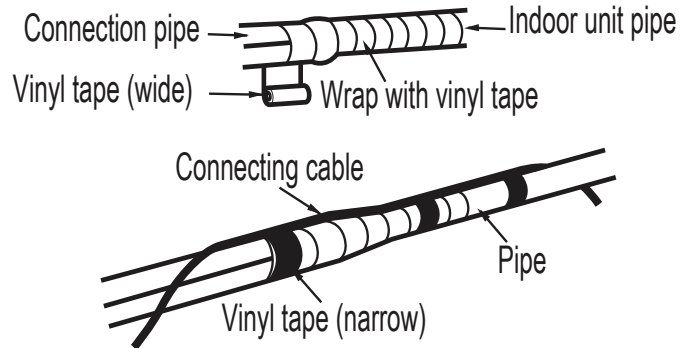
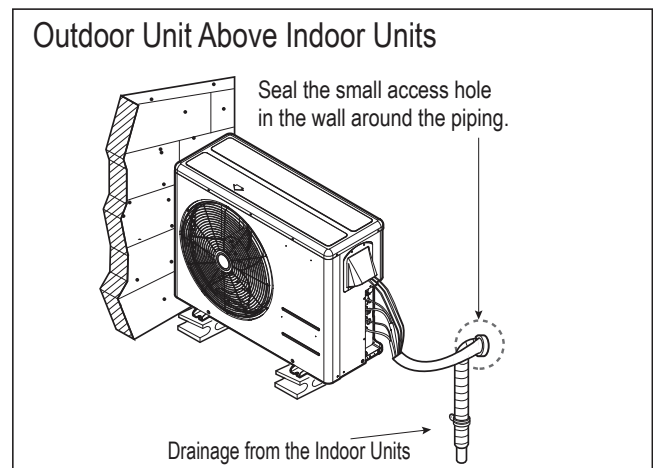
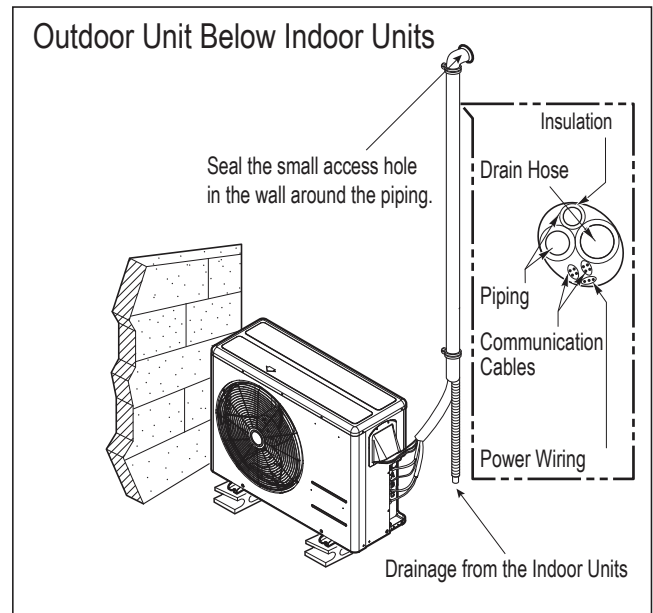


Figure 63: Special Applications.



---

---

## Condensate Drain Piping

Outdoor unit requires condensate drain piping. Condensate drain pipe must be constructed with materials approved by local code. See pages 21 to 25 for information in reference to outdoor unit placement and condensate drainage.

### Drain Leak Test

A leak test must be performed 24 hours after the drainage system has been installed.

### Note:

*For indoor unit condensate drain piping information, see the Multi F / Multi F MAX Indoor Unit Engineering Manual, or the installation manual specific to the indoor unit type.*

## Note:

For information regarding insulation for underground or penetration situations, see the “General Refrigerant Piping System Information” section.

## General Piping System Insulation

All refrigerant piping from the outdoor unit to the indoor units / branch distribution units (Multi F MAX systems only) must be insulated correctly for safety and usage. Y-branch connections, refrigerant piping, field-provided isolation ball valves (if present), service valves, and elbows must be properly and completely insulated using closed cell pipe insulation (up to the indoor unit piping connections). To prevent heat loss / heat gain through the refrigerant piping, all refrigerant piping including liquid lines and vapor lines must be insulated separately. Insulation must be a minimum 1/2 inches thick, and thickness will need to be increased based on ambient conditions and local codes. Table on the next page lists minimum wall thickness requirements for Ethylene Propylene Diene Methylene (EPDM) insulation.

Inside the outdoor unit, maximum pipe temperature is 248°F and minimum pipe temperature is -40°F. For field insulation of refrigerant piping between outdoor units and indoor units, consider the following pipe temperature ranges for an operating heat pump system:

- Heating mode refrigerant temperature ranges: Liquid, 75-118°F; High Pressure Vapor, 95-220°F.
- Cooling mode refrigerant temperature ranges: Liquid, 75-118°F; Low Pressure Vapor, 40-90°F.

All insulation joints must be glued with no air gaps. Insulation material must fit snugly against the refrigeration pipe with no air space between it and the pipe. Insulation passing through pipe hangers, inside conduit, and/or sleeves must not be compressed. Protect insulation inside hangers and supports with a second layer. All pipe insulation exposed to the sun and outdoor elements must be properly protected with PVC, aluminum vapor barrier, or alternatively placed in a weather-resistant enclosure such as a pipe rack with a top cover; and meet local codes. LG-provided Y-branches are shipped from the factory with pre-formed peel-and-stick foam insulation jackets, with a 1.84 lb./ft.<sup>3</sup> density, 1/2 inch thickness, and meet UL94 MF-1 flammability.

The design engineer must perform calculations to determine if the factory-supplied insulation jackets are sufficient to meet local codes and avoid sweating. Add additional insulation if necessary. Check the fit of the insulation jacket after the Y-branch fitting and all run-out pipes are installed.

Figure 64: Typical Pipe Insulation, Power Wire and Communications Cable Arrangement

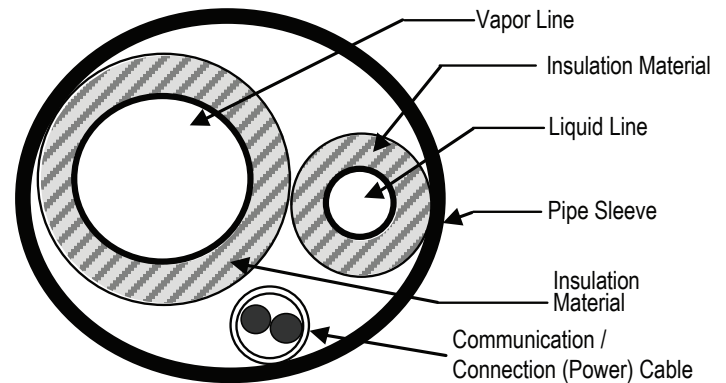


Figure 65: Typical Insulation Butt-Joint at Indoor Unit Casing.

Figure 66: Typical Refrigerant Flare Fitting Insulation Detail.

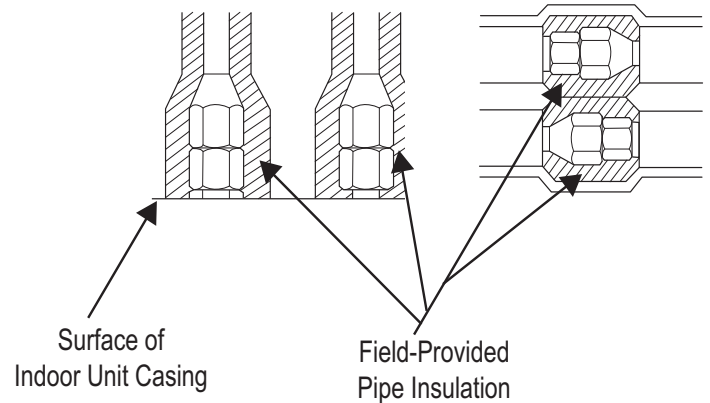
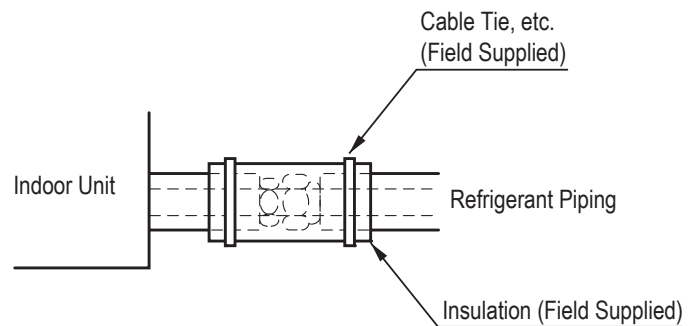


Figure 67: Insulating the Shut Off / Isolation Ball Valve (If Present).



## Minimum Refrigerant Pipe Ethylene Propylene Diene Methylene (EPDM) Insulation Wall Thickness Requirements

### Note:

- Do not insulate gas and liquid pipes together as this can result in pipe leakage and malfunction due to extreme temperature fluctuations.
- Always properly insulate the piping. Insufficient insulation will result in condensation, reduced heating/cooling performance, etc. Also, if the pipes aren't insulated properly, condensation could potentially cause damage to building finishes. Pay special attention to insulating the pipes installed in the ceiling plenum.
- Fully insulate the piping connections.
- Follow local codes and the designer's instructions when selecting ethylene propylene diene methylene (EPDM) insulation wall thickness.

Table 32: Minimum Refrigerant Pipe EPDM Insulation Wall Thickness Requirements.<sup>1</sup>

Classification		Air-conditioned location		Non-air conditioned location	
		1. Typical Conditioned Location	2. Special Conditioned Location	3. Typical Unconditioned Location	4. Special Unconditioned Location
Liquid pipe	ø1/4 inch	>1/2 inch	>1/2 inch	>1/2 inch	>1/2 inch
	ø3/8 inch	>1/2 inch	>1/2 inch	>1/2 inch	>1/2 inch
	≥ø1/2 inch	>1/2 inch	>1/2 inch	>1/2 inch	>1/2 inch
Vapor pipe	ø3/8 inch	>1/2 inch	>3/4 inch	>3/4 inch	>1 inch
	ø1/2 inch				
	ø5/8 inch				
	ø3/4 inch				
	ø7/8 inch				
	ø1 inch	>3/4 inch	>1 inch	>1 inch	
	ø1-1/8 inches				
	ø1-1/4 inches				
	ø1-3/8 inches				
	ø1-1/2 inches				
ø1-3/4 inches					

<sup>1</sup>The thickness of the above insulation material is based on heat conductivity of 0.61 Btu/in/h/ft<sup>2</sup>/°F.

### 1. Typical Conditioned Location

A building plenum or space that contains conditioned air that does not exceed 80°F DB.

### 2. Special Conditioned Location

1. When the location is air conditioned, but there is severe temperature/humidity difference due to high ceilings.
  - Church, auditorium, theater, lobby, etc.
2. When the location is air conditioned, but internal temperature/humidity are high.
  - Bathroom, swimming pool, locker room, etc.

### 3. Typical Unconditioned Location

An unconditioned space inside a building.

### 4. Special Unconditioned Location: If conditions 1 and 2 below are present.

1. An unconditioned space or plenum of a building.
2. An area where there is an elevated humidity level.

### 5. Additional Insulation for Indoor Units Will be Required in Humid Environments.

The air conditioner factory insulation has been tested according to "ISO Conditions with Mist," and it satisfies the requirements. If the system has been operating for a long time in a high humidity environment (dew point temperature: more than 73°F), condensate is likely to form. If this happens, install 3/8 inch thick EPDM insulation that is plenum-rated with a heat-resistance factor of more than 248°F.

## Note:

- Do not insulate gas and liquid pipes together as this can result in pipe leakage and malfunction due to extreme temperature fluctuations.
- Be sure to fully insulate the piping connections.

## Installing the Insulation

1. Insulation material must be longer than the refrigerant piping. Each vapor and liquid piping must be insulated separately.
2. Place the closed-cell ethylene propylene diene methylene (EPDM) insulation material carefully around each refrigerant pipe so as not to damage it. Be sure the insulation material cutting line is placed upward.
3. Apply adhesive to both cut surfaces of the insulation and press together. Allow adhesive to dry so that the bond is secure and does not come apart.

## Insulating Piping Joints

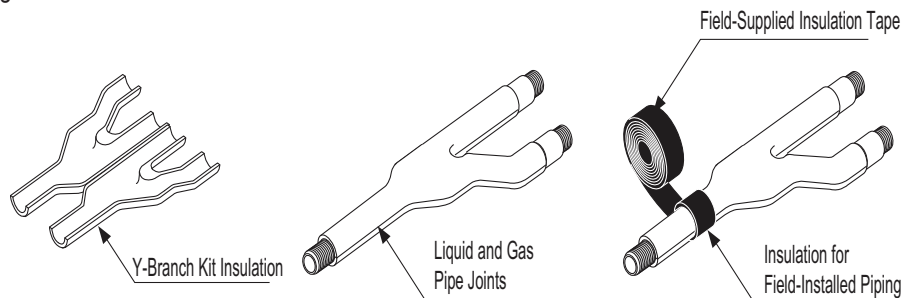
1. Push the EPDM insulation from the straight piping surrounding the joint (elbow, outdoor unit to indoor unit piping connection point, etc.) as close together as possible.
2. Cut a piece of insulation to fit the joint, overlapping the insulation on the surrounding piping by at least one (1) inch.
3. Apply adhesive to bond all the ends.
4. Secure by completely wrapping narrow vinyl tape around the insulation / joint so that there are no gaps.
5. Tape must be sufficient to cover the piping so it can fit into the rear piping housing area at the back of the indoor unit or branch distribution unit (Multi F MAX systems only).

## Y-Branch Kit Insulation

Each Y-branch kit comes with clam-shell type peel-and-stick insulation jackets molded to fit the Y-branch fittings—one for the liquid line, one for the vapor line.

- Check the fit of the Y-branch clam-shell insulation jacket after the Y-branch is installed.
- Mark all the pipes at the points where the insulation jacket ends.
- Remove the jacket.
- Install field-provided insulation on the run-out and main pipes first.
- Peel the adhesive glue protector slip from the insulation jacket, and install the clam-shell jacket over the fitting.

Figure 70: Y-branch Insulation Detail.



## Note:

### Additional Insulation for Y-Branches Will be Required in Humid Environments.

If the system has been operating for a long time in a high humidity environment (dew point temperature: more than 73°F), condensate is likely to form. If this happens, install 3/8 inch thick ethylene propylene diene methylene (EPDM) insulation that is plenum-rated with a heat-resistance factor that follows applicable local, state, and federal codes.

Figure 68: Correct Cutting Line Placement.

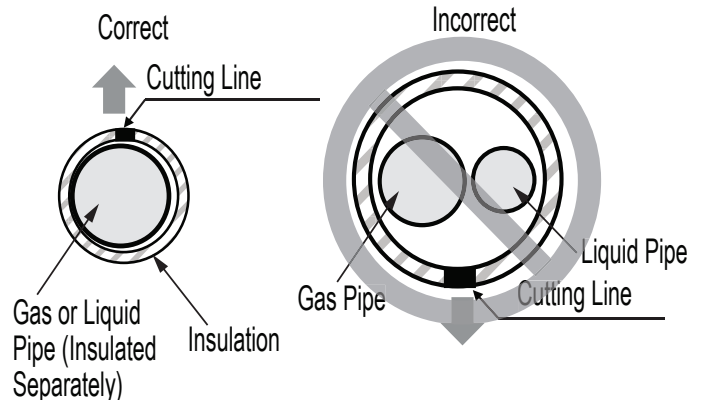
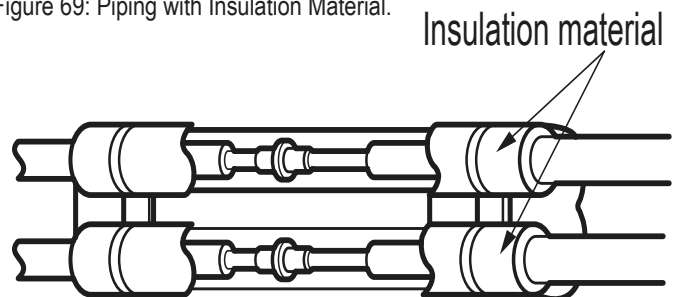


Figure 69: Piping with Insulation Material.





**⚠ WARNING**

- All power (line voltage) wiring and communication cable installation must be performed by trained service providers working in accordance with all local, state, and National Electrical Code (NEC) / UL / ETL federal regulations related to electrical equipment and wiring, and following the manufacturer product diagrams, requirements, and instructions in this manual. Electric shock can cause physical injury or death.
- Be sure that main power to the unit is completely off before proceeding. Follow all safety and warning information outlined at the beginning of this manual. Failure to do so will cause electric shock and bodily injury.
- Install a main shutoff switch or circuit breaker that interrupts all power sources simultaneously (circuit breaker must be resistant to electromagnetic currents). Be sure that the circuit breaker or some other emergency power cutoff device is in place before any power wiring is done to the system. Failure to do so will cause bodily injury or death.
- ⚡ Never touch any power lines or live cables before all power is cutoff to the system. To do so will cause bodily injury or death.
- Power wiring and communication cable sizes must comply with all applicable federal, state, and local codes. Undersized wiring will lead to unacceptable voltage at the unit and will cause a fire, which will cause bodily injury or death.
- Properly ground the outdoor unit, indoor units, and branch distribution units. Ground wiring must always be installed by a trained technician. Ground wiring is required to prevent accidental electrical shock during current leakage, which will cause bodily injury or death.
- Verify that the circuit breaker is set to OFF before installing the wiring system. Electric shock can cause physical injury or death.
- Install appropriately sized breakers / fuses / overcurrent protection switches and wiring in accordance with local, state, and NEC regulations related to electrical equipment and wiring, and following the instructions in this manual. Generated overcurrent will include some amount of direct current. Using an oversized breaker or fuse will result in electric shock, physical injury or death.
- ⚡ Do not connect ground wire to refrigerant, gas, sewage, or water piping; to lightning rods; to telephone ground wiring; or to the building plumbing system. Failure to properly provide a NEC-approved earth ground can result in electric shock, fire, physical injury or death.

**Note:**

- Consider ambient conditions (temperature, direct sunlight, inclement weather, etc.) when selecting, installing, and connecting the power wiring.
- Properly ground the outdoor unit, indoor units, and branch distribution units. Ground wiring must always be installed by a trained technician. Improperly grounded wire can cause communication problems from electrical noise, and motor current leakage.
- Install appropriately sized breakers / fuses / overcurrent protection switches and wiring in accordance with local, state, and NEC regulations related to electrical equipment and wiring, and following the instructions in this manual. Generated overcurrent will include some amount of direct current. Using an oversized breaker or fuse will result in equipment malfunction and property damage.
- ⚡ Do not connect ground wire to refrigerant, gas, or water piping; to lightning rods; to telephone ground wiring; or to the building plumbing system. Failure to properly provide a NEC-approved earth ground can result in property damage and equipment malfunction.
- ⚡ Do not operate the air conditioning system until the refrigerant piping installation is complete. Operating the system before refrigerant piping is finalized will damage the compressor.

**Location / Accessing the Power Wiring and Communications Cable Connections**

1. Detach the outdoor unit panel by loosening the screws.
2. Remove the control cover (if applicable) by loosening the screws.
3. When all connections are complete, re-attach the cover control to its original position using the screws, then re-attach the outdoor unit panel.

Figure 71: Power Wiring and Communication / Connection (Power) Cable Paths (LMU18~36CHV; LMU480, 540HV Example) (Appearances Will Vary).

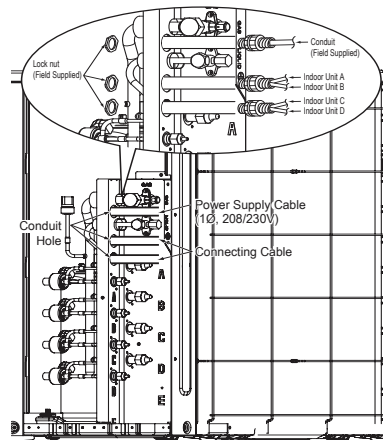
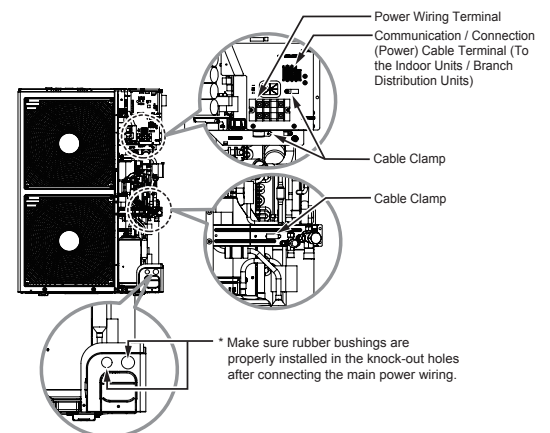


Figure 72: Location of the Power Wiring and Communication Cable Terminals (LMU600HV).



### Power Wiring / Communication Cable Connections

Best practice dictates using solderless ring or fork terminals at all power wiring and communication cable terminations. Use copper bearing ring or fork terminals; do not use galvanized or nickel plate over steel. Use appropriate crimping tool to attach the ring or fork terminals at all power wiring and control cable terminations.

#### To Install a Ring or Fork Terminal:

1. Trim the wiring with wire cutters or pliers, then strip the insulation to expose the strand wiring to about 3/8 inches.
2. Using a ring terminal fastener or pliers, securely clamp a ring terminal to each stripped wire end.

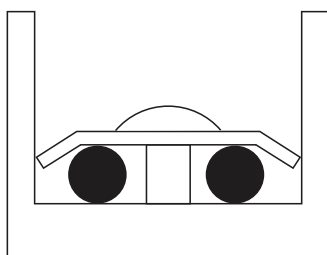
#### To Connect the Wiring to the Terminals:

1. Remove the JIS terminal screws from the (outdoor unit, branch distribution unit, or indoor unit) terminal plate with a JIS screwdriver. (See information about LG terminal connections on the next page.)
2. Position the ring terminal around the terminal, place the terminal screw in the ring, and tighten to the terminal plate using a JIS screwdriver.
  - Firmly attach the wire; secure in a way to prevent external forces from being imparted to the terminal block.
  - Use an appropriately sized JIS screwdriver for tightening the terminals.
  - Do not over tighten the connections; over tightening will damage the terminals.

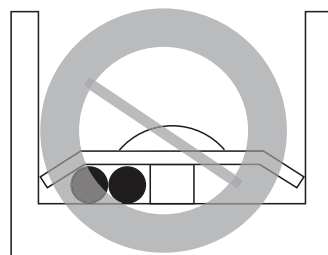
If ring terminals or fork terminals are not available, then:

- Do not terminate different gauge wires to the power terminal block. (Slack in the wiring will generate heat.)
- When terminating wires of the same thickness, follow the instructions demonstrated in the figures below.

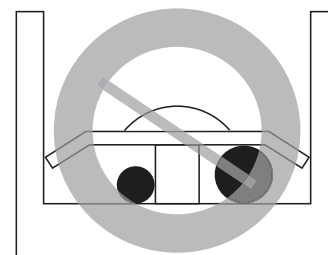
Figure 76: Proper and Improper Power Wiring Connections.



Terminate multiple power wires of the same gauge to both sides.



Do not terminate two wires on one side.



Do not terminate different gauge wires to a terminal block.

:Copper Wire

### WARNING

If power wires are not properly terminated and firmly attached, there is risk of fire, electric shock, and physical injury or death.

#### Note:

- Never apply line voltage power to the communications cable terminal block. If contact is made, the PCBs will be damaged.
- Always include some allowance in the wiring length when terminating. Firmly attach the wiring or cable, but provide some slack to facilitate removing the electrical panels while servicing, and to prevent external forces from damaging the terminal block.

Figure 73: Close up of a Typical Ring Terminal.

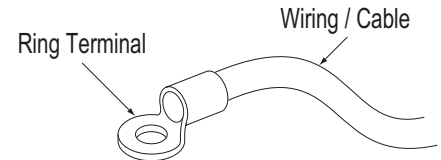


Figure 74: Adding a Ring Terminal to the Wiring.

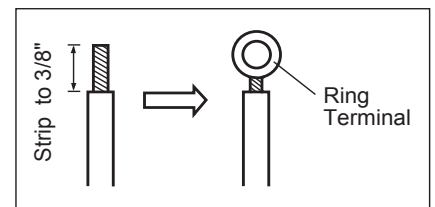
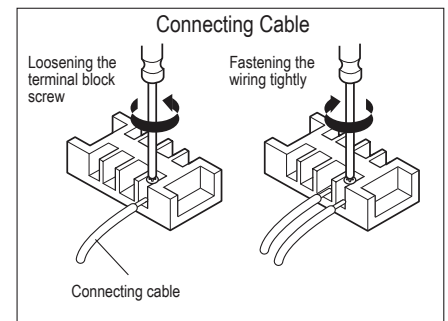


Figure 75: Tightening the Ring Terminal to the Terminal Plate.



## LG Terminal Connections

LG uses a “JIS” type of screw for all terminals; use a JIS screwdriver to tighten and loosen these screws and avoid damaging the terminal. ⚠ Do not over tighten the connections — over tightening will damage the terminals — but firmly and securely attach the wiring in a way to prevent external forces from being imparted to the terminal block.

### Note:


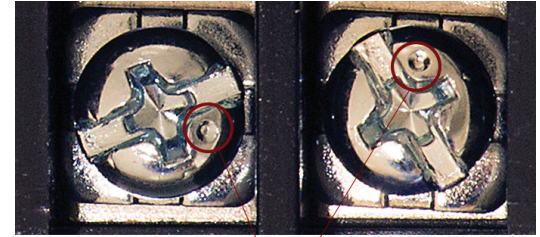
- The terminals labeled “GND” are NOT ground terminals. The terminals labeled  ARE ground terminals.
- Polarity matters. Always connect “A” to “A” and “B” to “B.”
- Always create a wiring diagram that contains the exact sequence in which all the indoor units and branch distribution units (Multi F MAX systems only) are wired in relation to the outdoor unit.
- ⚠ Do not include splices or wire nuts in the communication cable.

Figure 77: JIS Screws.



JIS DIMPLES

## Power Supply / Power Wiring Specifications

- Multi F and Multi F MAX systems operate at 1Ø, 208-230V, 60Hz, and power is wired to the outdoor unit only. The outdoor unit will supply power to the indoor units and the branch distribution units (Multi F MAX systems only) through the communication / connection (power) cable.
- Power supply to the outdoor unit must be selected based on NEC and local codes. Maximum allowable voltage fluctuation  $\pm 10\%$  or nameplate rated value.
- Power wiring to the outdoor unit(s) must be solid or stranded, and must comply with all local and national electrical codes.
- Properly ground the outdoor unit and indoor unit per NEC and local codes.
- Ground wire must be longer than the common power / communication wires.
- Connect the wiring firmly so the wires cannot be easily pulled out.
- Refer to the inside of the chassis cover or control cover for circuit and terminal block diagrams.
- Always match color codes of each wire and follow wiring diagram.
- ⚠ Do not install power wiring to the outdoor unit and the communication / connection (power) cable to the indoor unit in the same conduit. Use separate conduits.

Figure 79: Multi F / Multi F MAX Outdoor Unit Power Wiring.

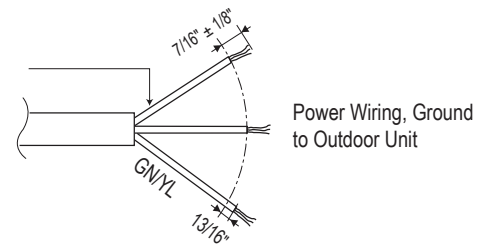
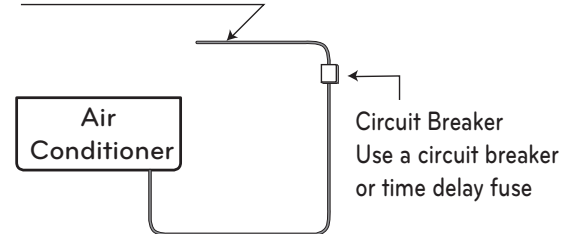


Table 33: Circuit Breaker / Fuse Size.

Outdoor Unit Model	Power Source	Fuse or Breaker Capacity
LMU18*HV, LMU24*HV	1Ø, 208-230V	20A
LMU30CHV, LMU36CHV	1Ø, 208-230V	25A
LMU480HV, LMU540HV	1Ø, 208-230V	40A
LMU600HV	1Ø, 208-230V	45A

Figure 78: Circuit Breaker Main Power Source



## ⚠ WARNING

- Always have a trained service provider properly ground the outdoor unit. If the outdoor unit is not properly grounded, there is a risk of electric shock, physical injury, or death.
- Provide a circuit breaker between the power source and the outdoor unit. Failure to do so will cause bodily injury or death.

### Communication / Connection (Power) Cable Specifications

• Multi F Systems:

- Communication / connection (power) cable from the outdoor unit to the indoor unit for lengths up to 130 feet must use a minimum of 14 AWG, four (4) conductor, stranded, shielded or unshielded (if shielded, it must be grounded to the chassis of the outdoor unit only), and must comply with applicable local and national codes.
- When the communication / connection (power) wires between the indoor unit and outdoor unit is GREATER THAN 130 feet, use:
  - A two (2) conductor wire for power (for each indoor unit).
  - A two (2) conductor wire for communication / ground (for each indoor unit).
  - Separate the power AT LEAST two (2) inches away from the communication / ground wire (for each indoor unit).
  - All wiring is still minimum 14 gauge, stranded, shielded, or unshielded as cited above (for each indoor unit).

• Multi F MAX Systems:

- All communication / connection (power) cable from the outdoor unit to the branch distribution unit(s) must be a minimum of 14 AWG, four (4) conductor, stranded, shielded or unshielded (if shielded, it must be grounded to the chassis of the outdoor unit only), and must comply with applicable local and national codes.
- Communication / connection (power) cable from the branch distribution unit(s) to the indoor units for lengths up to 130 feet must use a minimum of 14 AWG, four (4) conductor, stranded, shielded or unshielded (if shielded, it must be grounded to the chassis of the outdoor unit only), and must comply with applicable local and national codes.
- When the communication / connection (power) wires between the branch distribution unit and indoor unit is GREATER THAN 130 feet, use:
  - A two (2) conductor wire for power (for each indoor unit).
  - A two (2) conductor wire for communication / ground (for each indoor unit).
  - Separate the power AT LEAST two (2) inches away from the communication / ground wire (for each indoor unit).
  - All wiring is still minimum 14 gauge, stranded, shielded, or unshielded as cited above (for each indoor unit).

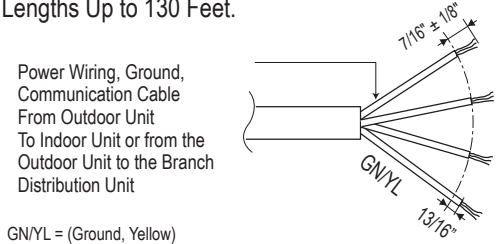
• Insulation material as required by local code.

• Rated for continuous exposure of temperatures up to 140°F.

• Firmly attach the cable; provide slack but secure in a way to prevent external forces from being imparted on the terminal block.

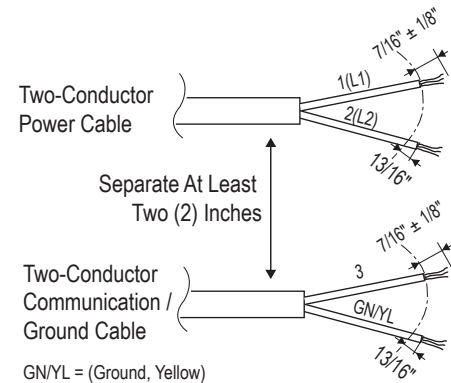
• Wiring must be completed without splices.

Figure 80: Typical Multi F / Multi F MAX Outdoor and Indoor / Branch Distribution Unit Wiring and Communications Cable Diagram For Wiring Lengths Up to 130 Feet.



GN/YL = (Ground, Yellow)

Figure 81: Multi F Outdoor Unit to Indoor Unit, and Multi F MAX Branch Distribution Unit to Indoor Unit Wiring Diagram for Wiring Lengths GREATER THAN 130 Feet.



GN/YL = (Ground, Yellow)

### Note:

- Use a conduit for the communications / connection (power) cable from the outdoor unit to the indoor units and branch distribution unit(s). Electrical interference may cause product malfunction.
- ⚠ Never ground the shield of the communications cable to the indoor unit frame or other grounded entities of the building. Ground the communications cable shield only at the outdoor unit. Improperly grounding this cable can cause communications errors.
- The communications / connection (power) cable from the outdoor unit to the indoor units / branch distribution unit(s) must be separated and isolated from power wiring to the outdoor unit, computers, radio and television broadcasting facilities, as well as medical imaging equipment. Electrical interference may cause product malfunction.



Figure 82: Typical Multi F System General Power / Communications System Schematic When Wiring is Less Than 130 Feet.

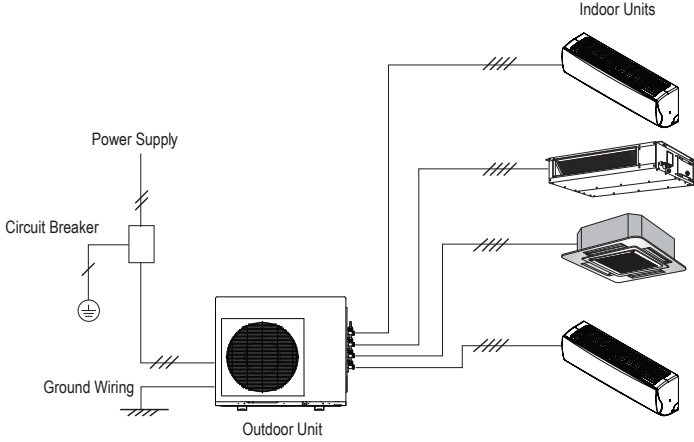


Figure 83: Typical Multi F MAX System General Power / Communications System Schematic When Wiring is Less Than 130 Feet.

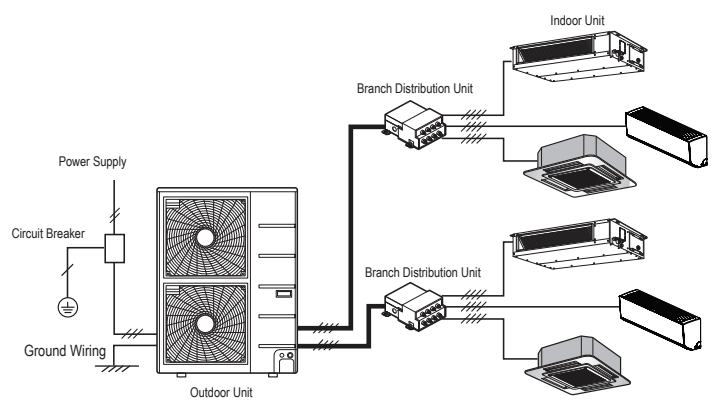


Figure 84: Schematic of a Multi F System When the Wiring is GREATER THAN 130 Feet.

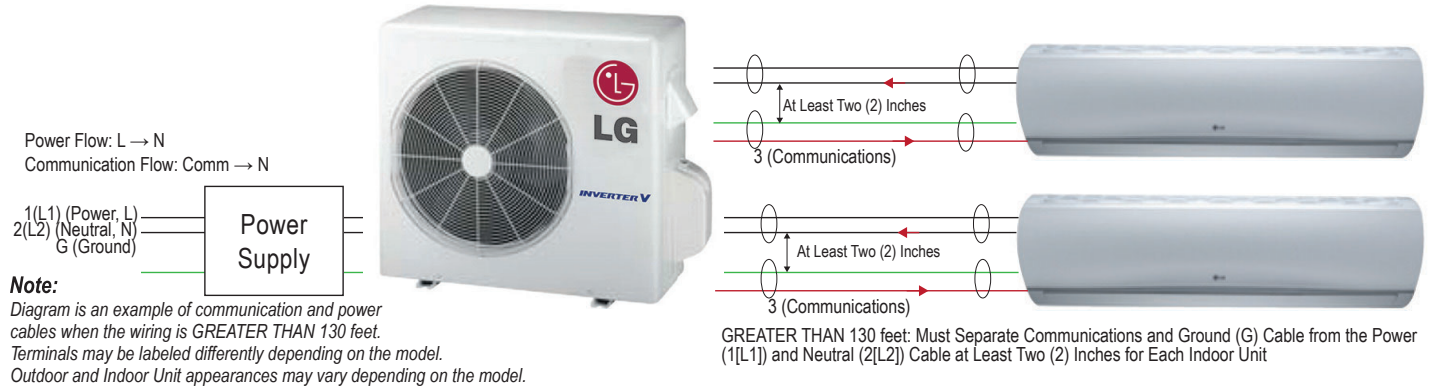


Figure 85: Schematic of a Multi F MAX System When the Wiring is GREATER THAN 130 Feet.

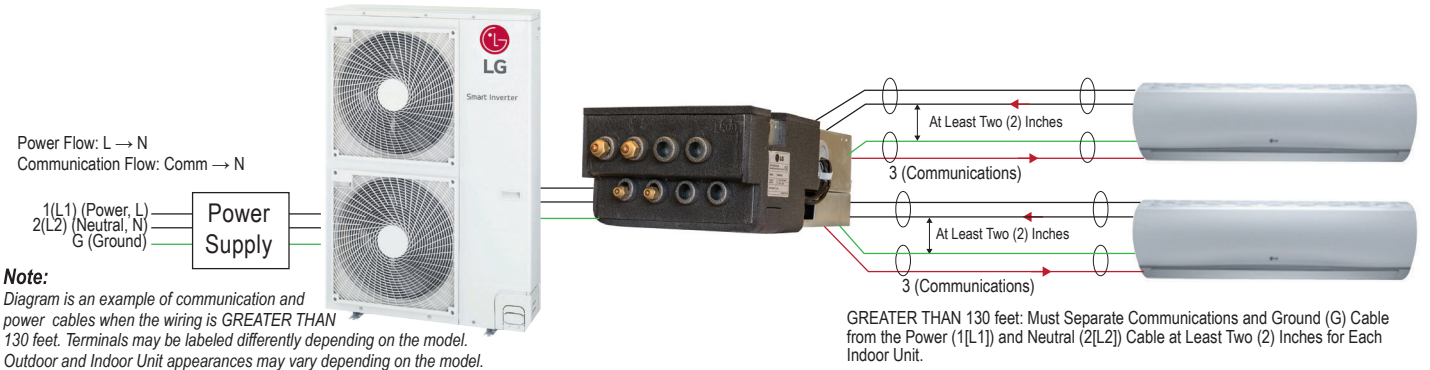
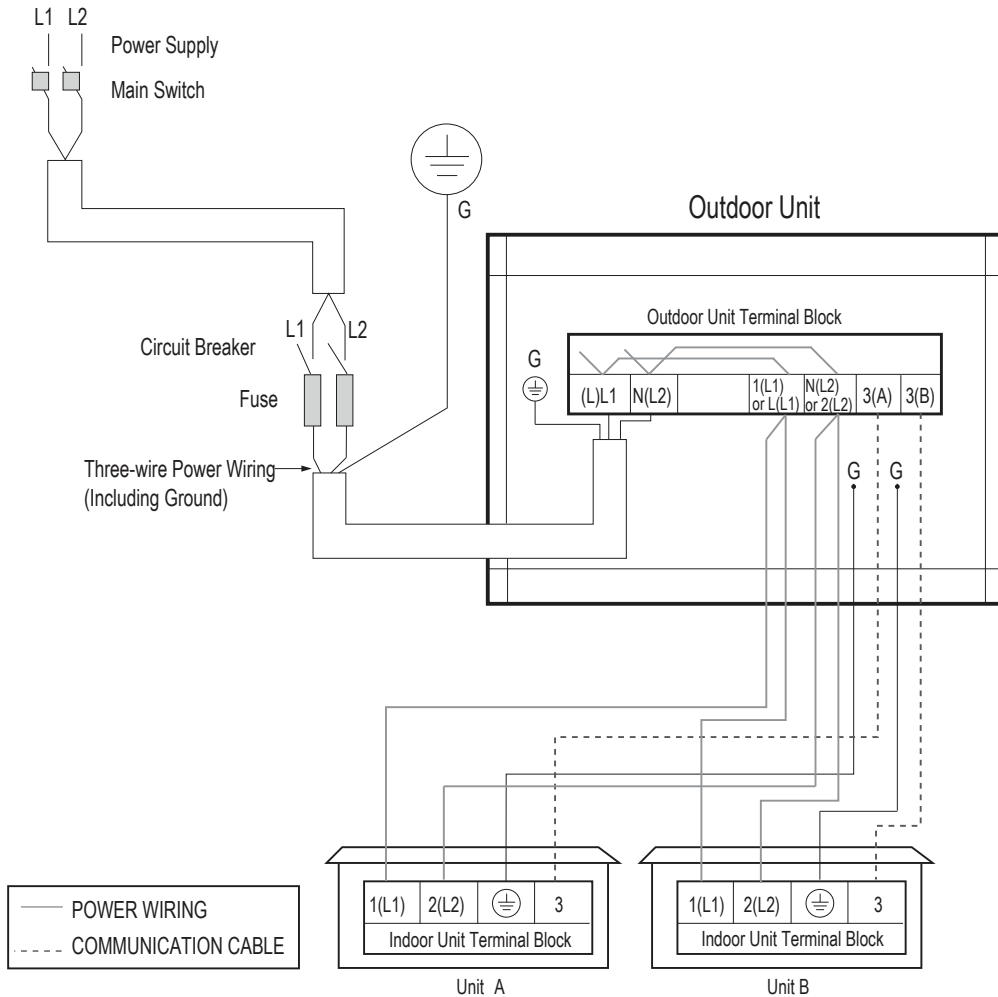


Figure 86: Multi F LMU180HV and LMU18CHV System Power Wiring and Communications Cable.



### ⚠ WARNING

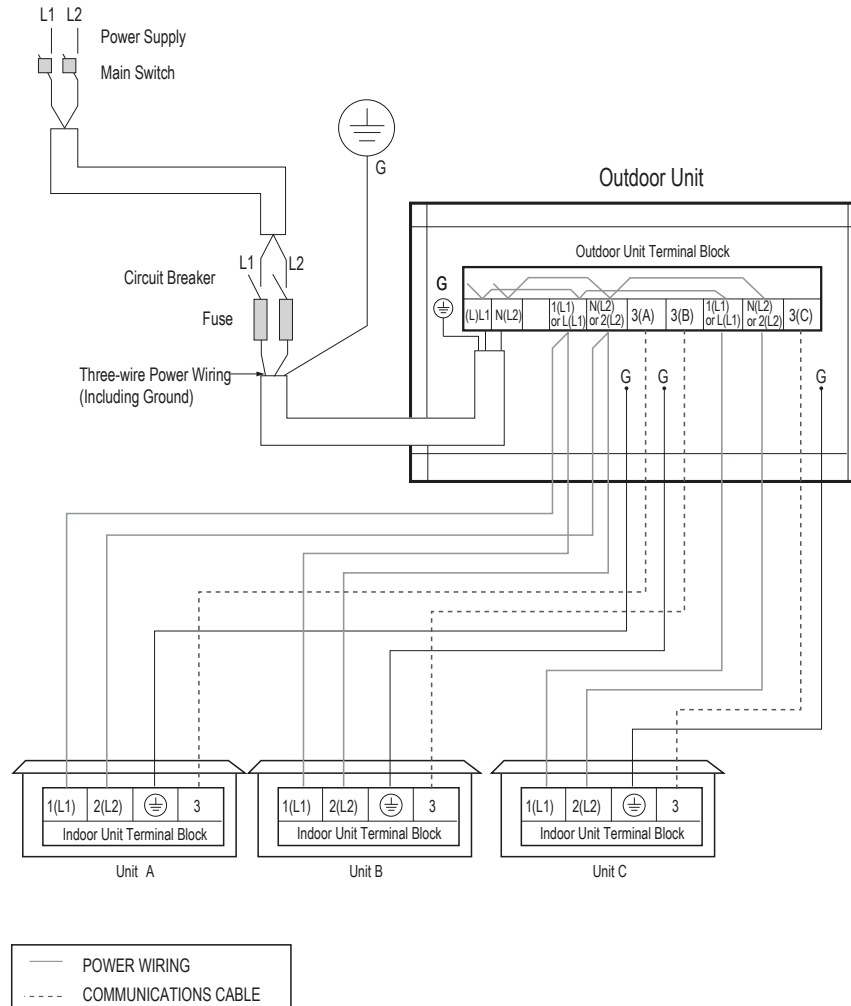
- All field-supplied wiring, components, and materials must comply with all applicable national, state, and local codes and requirements. Improper wiring will result in fire, electric shock, physical injury or death.
- Ground wiring is required to prevent accidental electrical shock during current leakage, communication problems from electrical noise, and motor current leakage. ⚡ Do not connect the ground line to the pipes. There is a risk of fire, electric shock, explosion, physical injury or death.
- Install a main shutoff switch or circuit breaker that interrupts all power sources simultaneously. There is a risk of fire, electric shock, explosion, physical injury or death.

### Note:

- All field-supplied wiring, components, and materials must comply with all applicable national, state, and local codes and requirements. Failure to install proper electrical components can result in property damage and equipment malfunction.
- Ground wiring is required to prevent communication problems from electrical noise, and motor current leakage. Failure to provide proper ground wiring can result in property damage and equipment malfunction.
- Install a main shutoff switch or circuit breaker that interrupts all power sources simultaneously. Failure to install proper electric components can result in property damage and equipment malfunction.
- Maintain polarity throughout the communication network. The system will malfunction if not properly wired.



Figure 87: Multi F LMU240HV and LMU24CHV System Power Wiring and Communications Cable.



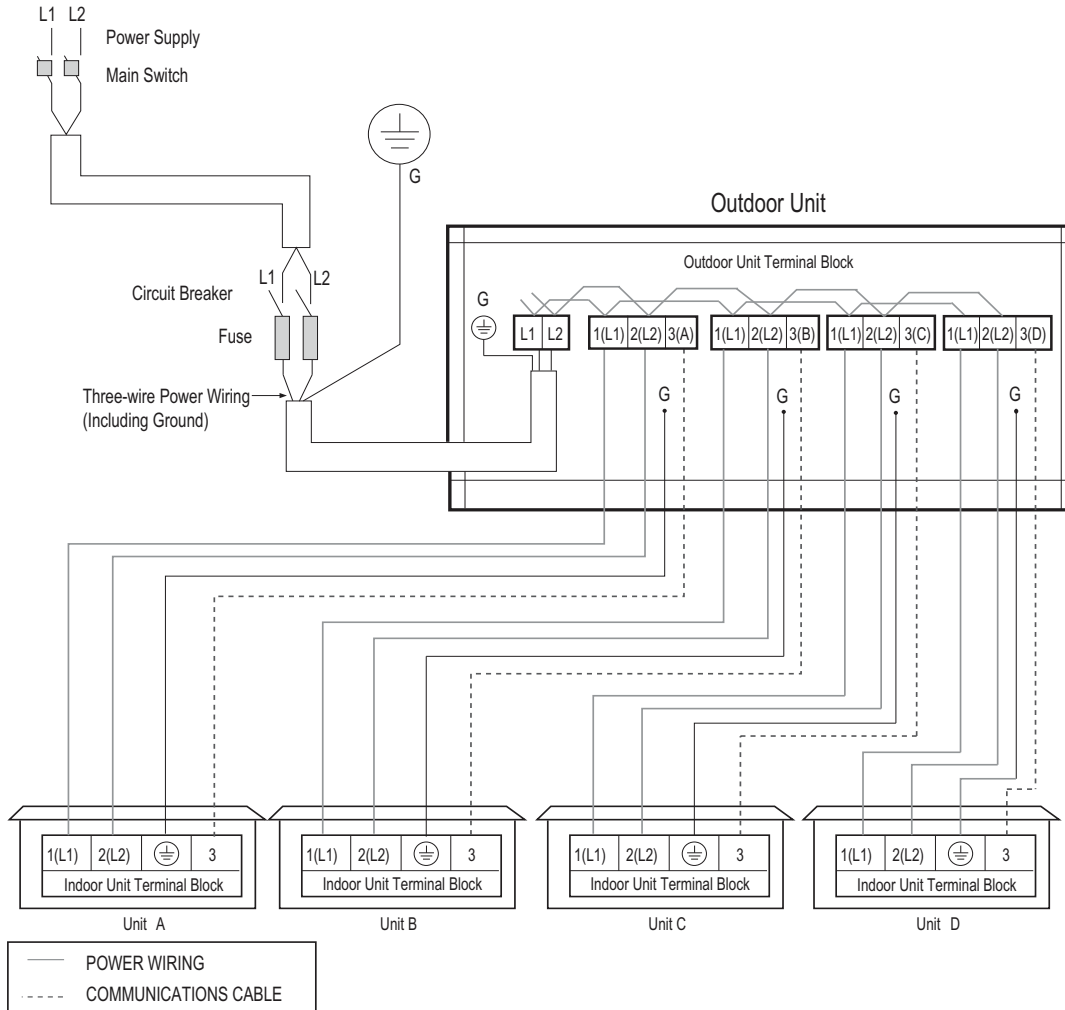
**⚠ WARNING**

- All field-supplied wiring, components, and materials must comply with all applicable national, state, and local codes and requirements. Improper wiring will result in fire, electric shock, physical injury or death.
- Ground wiring is required to prevent accidental electrical shock during current leakage, communication problems from electrical noise, and motor current leakage. ⚡ Do not connect the ground line to the pipes. There is a risk of fire, electric shock, explosion, physical injury or death.
- Install a main shutoff switch or circuit breaker that interrupts all power sources simultaneously. There is a risk of fire, electric shock, explosion, physical injury or death.

**Note:**

- All field-supplied wiring, components, and materials must comply with all applicable national, state, and local codes and requirements. Failure to install proper electrical components can result in property damage and equipment malfunction.
- Ground wiring is required to prevent communication problems from electrical noise, and motor current leakage. Failure to provide proper ground wiring can result in property damage and equipment malfunction.
- Install a main shutoff switch or circuit breaker that interrupts all power sources simultaneously. Failure to install proper electric components can result in property damage and equipment malfunction.
- Maintain polarity throughout the communication network. The system will malfunction if not properly wired.

Figure 88: Multi F LMU30CHV and LMU36CHV System Power Wiring and Communications Cable.



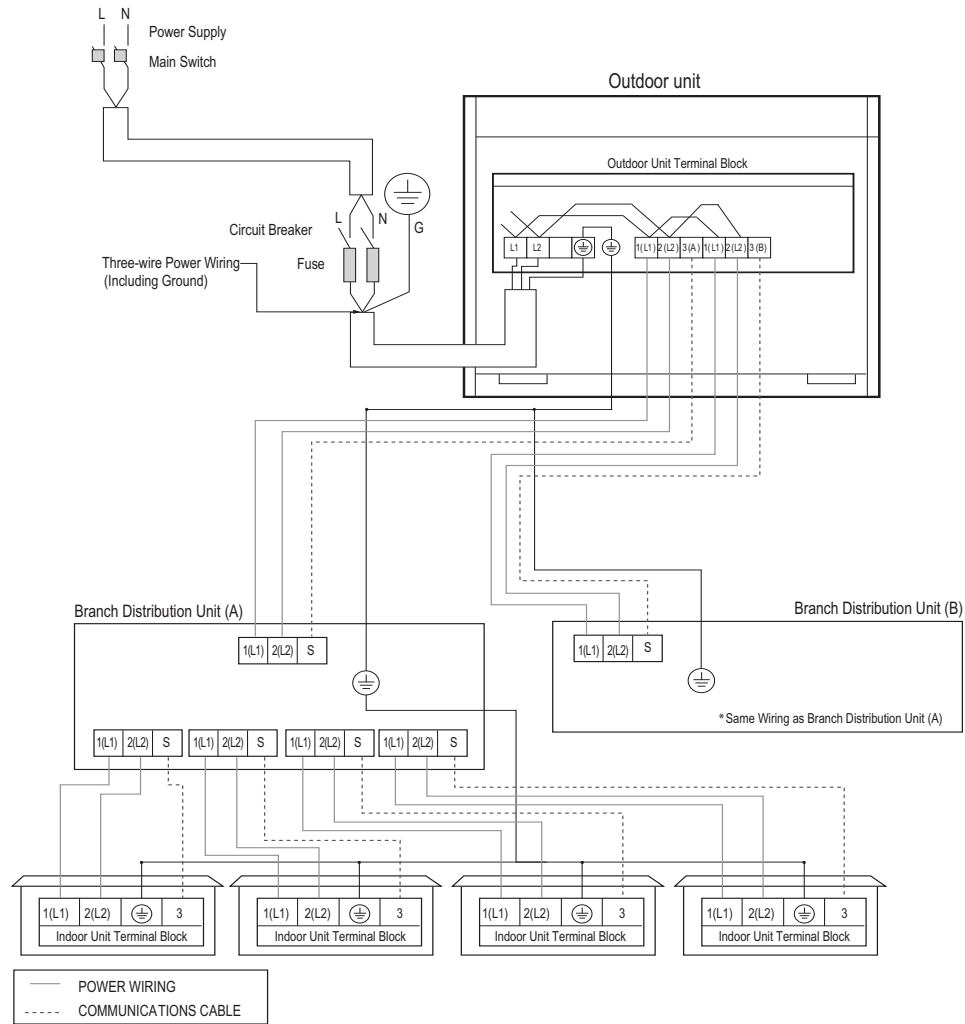
### ⚠ WARNING

- All field-supplied wiring, components, and materials must comply with all applicable national, state, and local codes and requirements. Improper wiring will result in fire, electric shock, physical injury or death.
- Ground wiring is required to prevent accidental electrical shock during current leakage, communication problems from electrical noise, and motor current leakage. ⚡ Do not connect the ground line to the pipes. There is a risk of fire, electric shock, explosion, physical injury or death.
- Install a main shutoff switch or circuit breaker that interrupts all power sources simultaneously. There is a risk of fire, electric shock, explosion, physical injury or death.

### Note:

- All field-supplied wiring, components, and materials must comply with all applicable national, state, and local codes and requirements. Failure to install proper electrical components can result in property damage and equipment malfunction.
- Ground wiring is required to prevent communication problems from electrical noise, and motor current leakage. Failure to provide proper ground wiring can result in property damage and equipment malfunction.
- Install a main shutoff switch or circuit breaker that interrupts all power sources simultaneously. Failure to install proper electric components can result in property damage and equipment malfunction.
- Maintain polarity throughout the communication network. The system will malfunction if not properly wired.

Figure 89: Multi F MAX LMU480HV and LMU540HV System Power Wiring and Communications Cable.



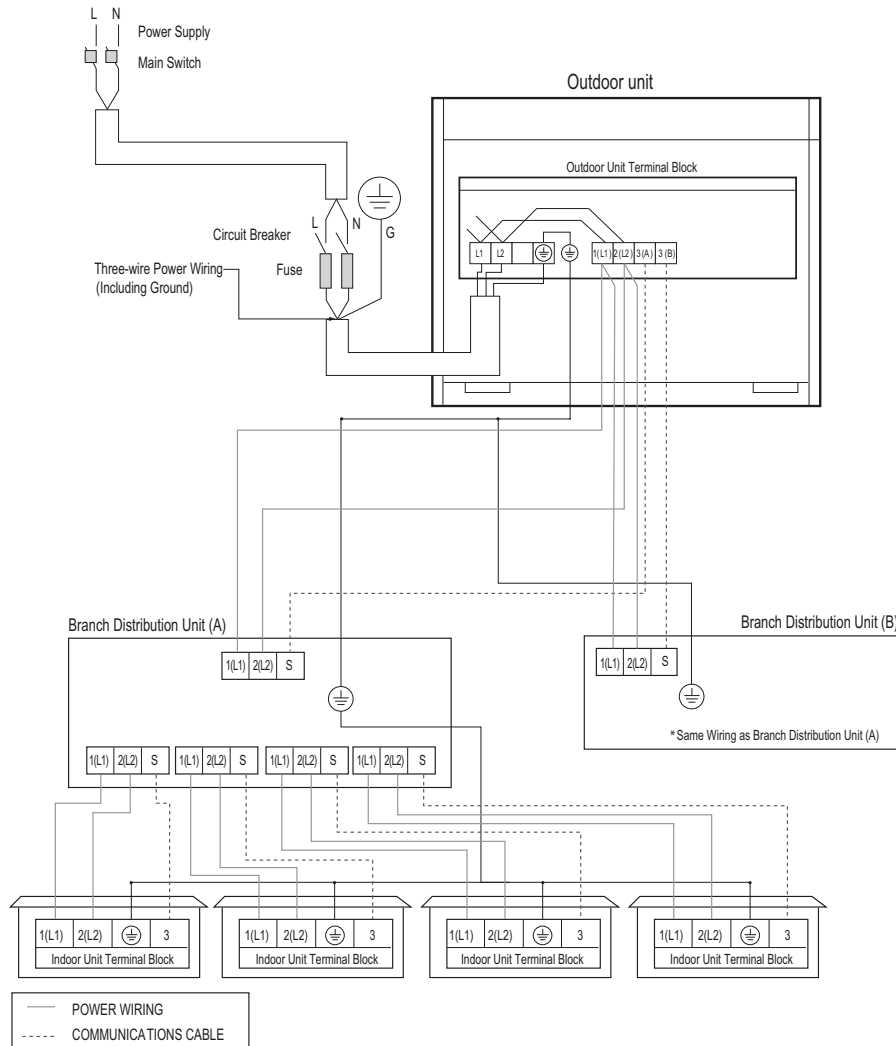
**⚠ WARNING**

- All field-supplied wiring, components, and materials must comply with all applicable national, state, and local codes and requirements. Improper wiring will result in fire, electric shock, physical injury or death.
- Ground wiring is required to prevent accidental electrical shock during current leakage, communication problems from electrical noise, and motor current leakage. ⚡ Do not connect the ground line to the pipes. There is a risk of fire, electric shock, explosion, physical injury or death.
- Install a main shutoff switch or circuit breaker that interrupts all power sources simultaneously. There is a risk of fire, electric shock, explosion, physical injury or death.

**Note:**

- All field-supplied wiring, components, and materials must comply with all applicable national, state, and local codes and requirements. Failure to install proper electrical components can result in property damage and equipment malfunction.
- Ground wiring is required to prevent communication problems from electrical noise, and motor current leakage. Failure to provide proper ground wiring can result in property damage and equipment malfunction.
- Install a main shutoff switch or circuit breaker that interrupts all power sources simultaneously. Failure to install proper electric components can result in property damage and equipment malfunction.
- Maintain polarity throughout the communication network. The system will malfunction if not properly wired.

Figure 90: Multi F MAX LMU600HV System Power Wiring and Communications Cable.



### ⚠ WARNING

- All field-supplied wiring, components, and materials must comply with all applicable national, state, and local codes and requirements. Improper wiring will result in fire, electric shock, physical injury or death.
- Ground wiring is required to prevent accidental electrical shock during current leakage, communication problems from electrical noise, and motor current leakage. ⚡ Do not connect the ground line to the pipes. There is a risk of fire, electric shock, explosion, physical injury or death.
- Install a main shutoff switch or circuit breaker that interrupts all power sources simultaneously. There is a risk of fire, electric shock, explosion, physical injury or death.

### Note:

- All field-supplied wiring, components, and materials must comply with all applicable national, state, and local codes and requirements. Failure to install proper electrical components can result in property damage and equipment malfunction.
- Ground wiring is required to prevent communication problems from electrical noise, and motor current leakage. Failure to provide proper ground wiring can result in property damage and equipment malfunction.
- Install a main shutoff switch or circuit breaker that interrupts all power sources simultaneously. Failure to install proper electric components can result in property damage and equipment malfunction.
- Maintain polarity throughout the communication network. The system will malfunction if not properly wired.

## Connecting the Communications / Connection (Power) Cables

1. Detach the outdoor unit panels by loosening the screws.
2. Remove the control cover (if applicable) by loosening the screws.
3. Remove the conduit knock outs or access holes.
4. Pull the power wiring, and the communications / connection (power) cable into the outdoor unit (through the conduits, if applicable). Ensure there is enough length to connect to the terminals on the outdoor unit. Secure any conduits with field-supplied lock nuts.
5. Connect the power wiring, and the communications / connection (power) cable to the correct terminals on the outdoor unit.
6. Connect communications / connection (power) cable to the correct control board terminals on the indoor unit (or branch distribution unit[s] if Multi F MAX system).
7. Follow the wiring diagrams on the outdoor unit and indoor units (or branch distribution unit[s]) control covers. Ensure that the terminal board numbers and wiring color on the outdoor unit matches the terminal number and wiring color on the indoor unit or branch distribution unit(s).
8. Provide strain relief and help protect the connections by (separately) securing the wiring / cable to the outdoor unit with the factory-supplied clamps (up to 35 lbs.). Clamps are included near the terminal block. Zip ties can also be used to hold all cables in place.
9. For more installation information for specific indoor units, refer to the separate indoor unit installation manuals on [www.lghvac.com](http://www.lghvac.com).
10. When all connections are complete, reattach the control cover to its original position using the screws, then reinstall the outdoor unit panel.
11. After installation is complete, seal any gaps around the wiring in the panel access holes or the conduits.

### ⚠ WARNING

- Always have a trained technician properly ground the outdoor unit. If the outdoor unit is not properly grounded, there is a risk of electric shock, physical injury, or death.
- Failure to properly install wiring can result in electric shock, fire, physical injury or death.
- Failure to properly provide a NEC-approved earth ground can result in electric shock, fire, physical injury or death.
- Comply with local and national codes while running the wire from the indoor unit (and branch distribution units if Multi F MAX system) to the outdoor unit (size of wire and wiring method, etc). Incorrectly sized wiring will cause the terminal to overheat, generate a fire, and risk physical injury or death.
- All wiring / cable must be firmly connected to its terminal. Loose wiring will cause the terminal to overheat, generate a fire, and risk physical injury or death.
- Do not allow the wiring / cable to touch refrigerant tubing, the compressor, or any moving parts. It can result in electric shock, fire, physical injury or death.
- Replace all control box and panel covers. If cover panels are not installed securely, dust, water and animals will enter the outdoor unit, causing fire, electric shock, and physical injury or death.

### Note:

- Ensure the communications / connection (power) cable from the outdoor units to the indoor / branch distribution units, and the power wiring to the outdoor unit are separate; otherwise, the outdoor unit operation will be affected by electrical noise and will malfunction or fail.
- The communications / connection (power) cable from the outdoor unit to the indoor / branch distribution units must be separated and isolated from power wiring to the outdoor unit, computers, elevators, radio and television broadcasting facilities, as well as medical imaging equipment; otherwise, the outdoor unit operation will be affected by electrical noise and will malfunction or fail.
- All wiring / cable must be firmly connected to its terminals. Loose wiring will result in unit malfunction.

Figure 91: Connecting the Power Wiring / Communications Cables to the Outdoor Unit (LMU18~36\*HV; LMU480, 540HV) (Appearances Will Vary).

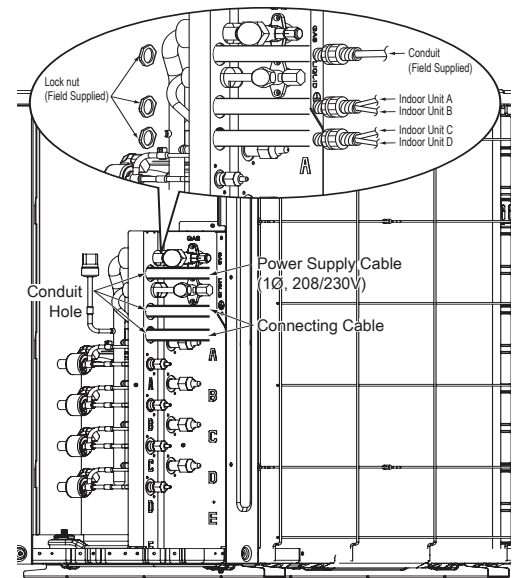


Figure 92: Connecting the Power Wiring / Communications Cables to the Outdoor Unit (LMU600HV).

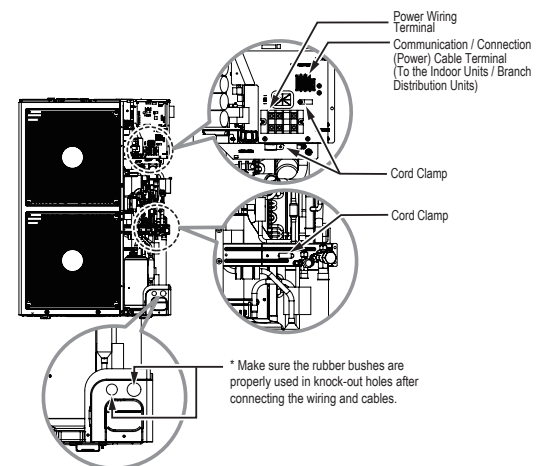
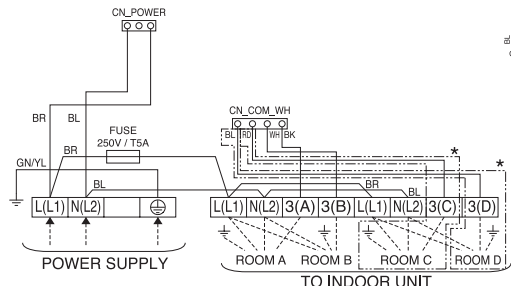
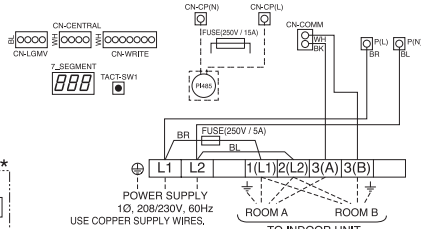


Figure 93: Detailed Diagrams of Outdoor Unit PCB Terminal Connections.

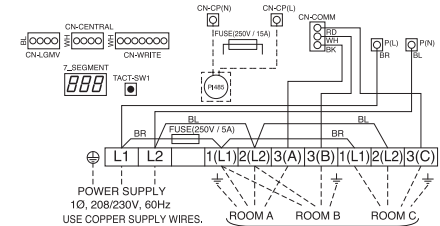
### Multi F LMU180HV and LMU240HV



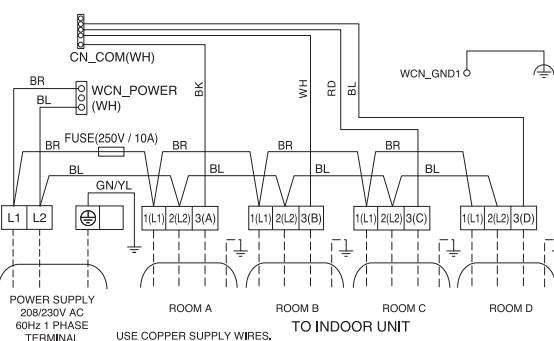
### Multi F LMU18CHV



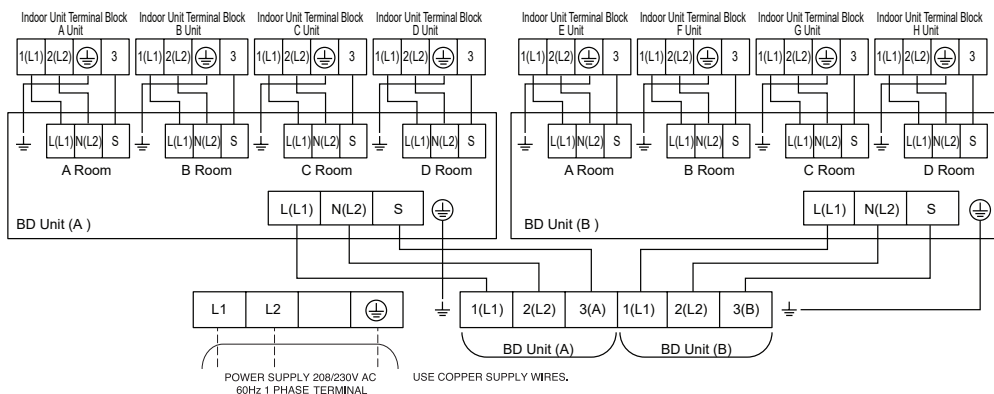
### Multi F LMU24CHV



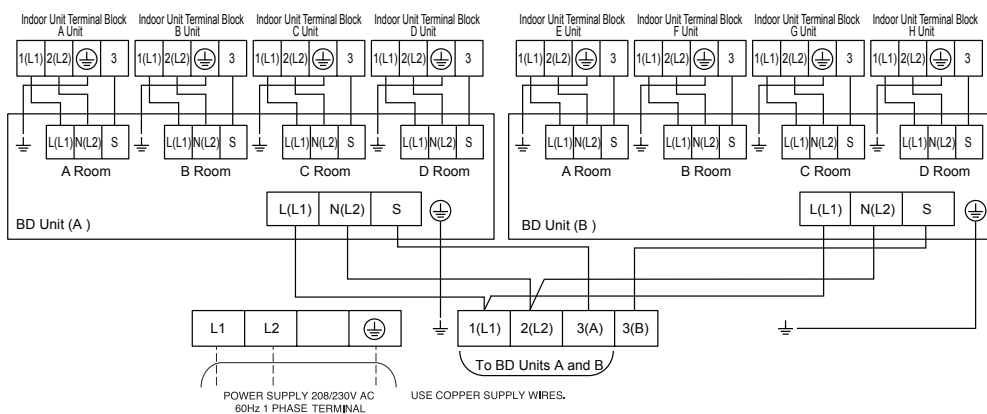
### Multi F LMU30CHV and LMU36CHV



### Multi F MAX LMU480HV and LMU540HV



### Multi F MAX LMU600HV



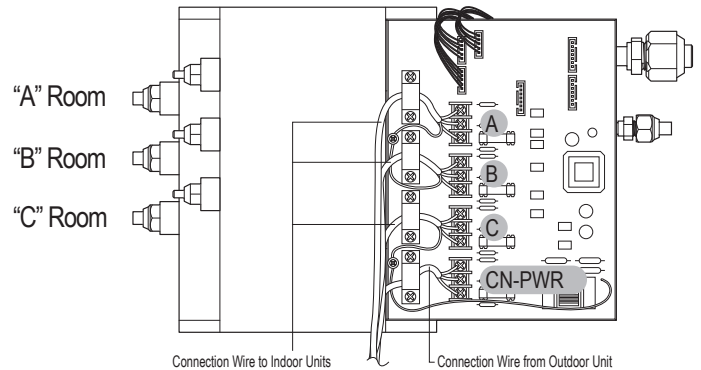


## Connecting the Communications / Connection (Power) Cable to the Branch Distributor Unit (Multi F MAX Systems Only)

### General Instructions

- Always connect power wiring / communications cable matching the branch distribution unit terminals to their respective indoor units (Example for three-port branch distribution unit PMBD3630: A, B, and C).
- Follow the instructions on the nameplates and connect wiring / cables of the outdoor unit and indoor units to the correct terminals. Always attach each ground wire separately to a grounding screw.
- After completion, secure wiring with wire clamps. Secure wiring firmly to the indoor unit.

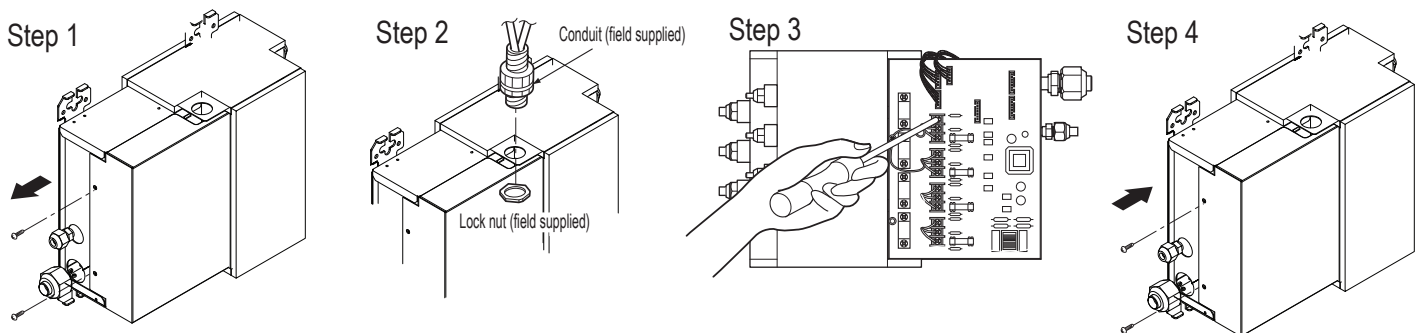
Figure 94: Interior View of a Branch Distribution Unit (Three-Port PMBD3630 Example Shown).



### Branch Distribution Unit Wiring Connection Procedure

1. Remove the branch distribution unit control cover. Unscrew the two (2) screws, and slide the cover off the branch distribution frame following the arrows in the diagram (Step 1).
2. Draw the communications / connection (power) cable from the outdoor unit so there is enough length to connect to the terminals on the branch distribution unit. Secure a field-supplied conduit to the branch distribution unit using a field-supplied lock nut on the interior of the branch distribution unit frame (Step 2). Pull the communication / connection (power) cable through the conduit into the branch distribution unit.
3. Connect communications / connection (power) cable from the outdoor unit to the branch distribution unit terminals, and from the branch distribution unit terminals to the indoor unit terminals following the wiring diagram on the outdoor unit control cover (Step 3). Allow 11-13/16 inches of slack in the wire harness. Attach communications / connection (power) cable to the branch distribution unit with clamps at four (4) locations.
4. Replace the branch distribution unit control cover following the arrows in the diagram. Tighten the two (2) screws to finish (Step 4).

Figure 95: Branch Distribution Unit Wiring Steps.



### ⚠ WARNING

⊘ Do not use tapped wires, stand wires, extension cords, or starburst-type connections as they will cause overheating, fire, electric shock, physical injury or death.

### Note:

Always refer to the circuit diagram on the inside of the outdoor unit control cover.

### PI-485

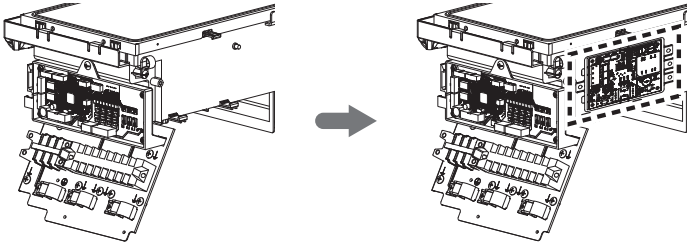
PI-485 V-net Control Integration Board for Outdoor Units adapt Multi F / Multi F MAX systems to a LG VRF system central protocol for integration with LG central controllers. The PI-485 is installed in the Multi F / Multi F MAX outdoor unit. For more information on PI-485 installation, see the PI-485 installation manual.

Figure 97: PI-485 Installation Area in Multi F and Multi F MAX Outdoor Units.

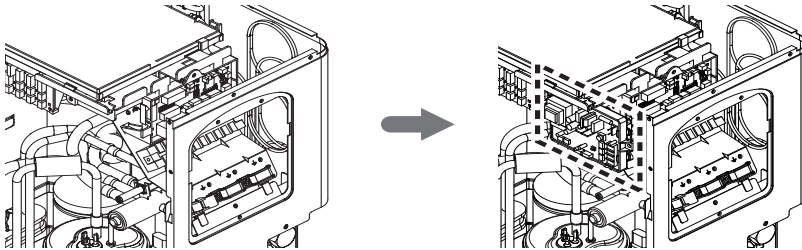
Figure 96: PI-485 Board (Appearance will differ depending on model).



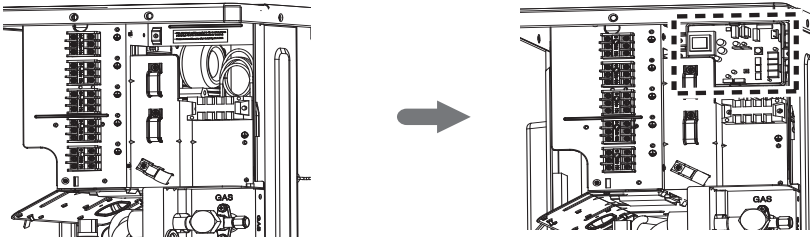
Multi F LMU180HV, LMU240HV



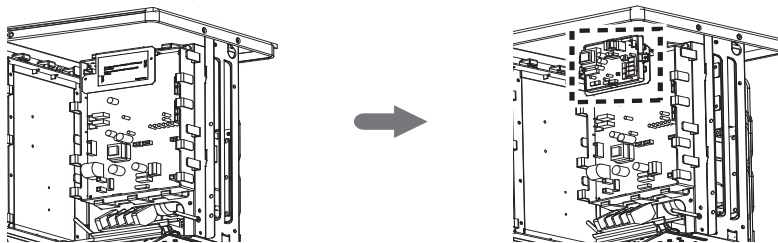
Multi F LMU18CHV, LMU24CHV



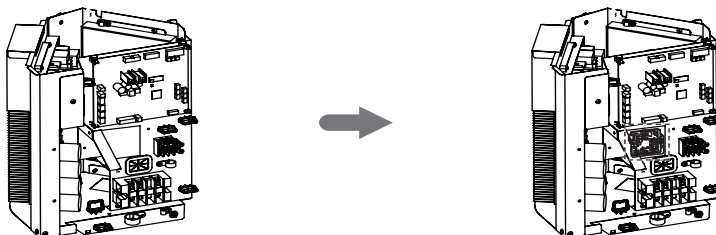
Multi F LMU30CHV, LMU36CHV



Multi F MAX LMU480HV, LMU540HV



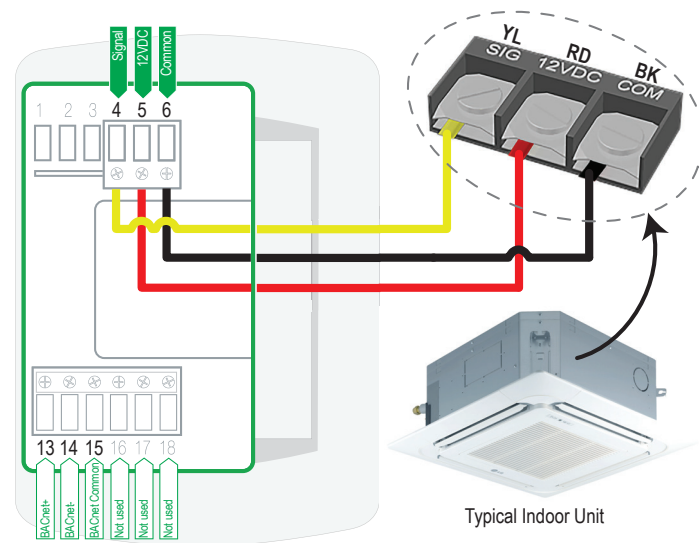
Multi F MAX LMU600HV



## From Indoor Units to Remote Controllers

- Communication cable from indoor unit to remote controller(s) is to be LG supplied or field supplied 22 AWG, 3-conductor, twisted, stranded, unshielded. Wiring must comply with all applicable local and national codes.
- If using the LG supplied cable and the length needs to be extended, the LG Extension Kit (sold separately) must be used. A maximum of four (4) kits (up to 165 feet) can be used.
- Remote controllers have hardwired connections: SIG - 12V - GND (Comm.) terminals.
- Indoor unit controller connections depend on type of indoor unit being installed. Some indoor units use terminal block connections; other indoor units use Molex connections. See diagrams below for the two options. Refer to the wiring diagram schematic found in the indoor unit itself, or to the indoor unit wiring diagrams in the Engineering Manuals for more information.
- ⚠ NEVER splice, cut, or extend LG supplied cable with field provided cable. Always include enough cable to cover distance between the indoor unit and the remote controller.
- Set the indoor unit operating parameters using DIP switches, or by setting up the remote controller. Refer to the indoor unit installation manuals for more details.

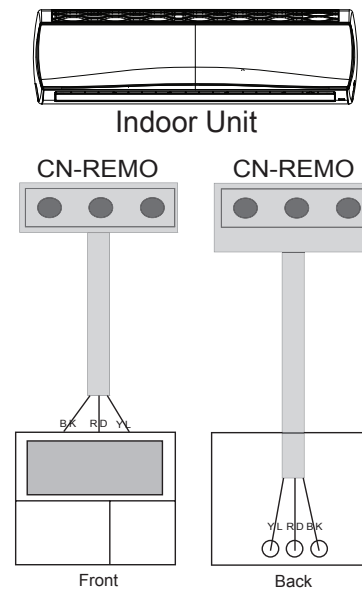
Figure 98: One Example of Indoor Unit to Zone Controller Connection.



### Note:

Cable connected to Zone Controller is the factory default connection.

Figure 99: Another Example of Indoor Unit to Zone Controller Connection.



### Between Multiple Indoor Units Operating as a Group (Group Control)

#### If any indoor units were specified to operate in unison:

- Before running cable, decide which indoor unit will be the "Main." The other indoor units in that group will be designated as "Sub(s)." The zone controller will be connected to the "Main."
- Set the pertinent DIP switch at each indoor unit to identify the Main and Sub(s). On wall mounted indoor unit models, set the assignment using the handheld remote controller.
- Use a daisy chain configuration and connect all of the group's indoor units together starting at the "Main" unit.
- ⚠ NEVER splice, cut, or extend cable length with field provided cable. Always include enough cable to cover distance between all components.

#### For indoor units with hardwired connections SIG - 12V - GND (Comm.) terminals:

- From the controller to the main indoor unit, use 22 AWG, 3-conductor, twisted, stranded, unshielded. All wiring must comply with all applicable local / national codes.
- From the main indoor unit to the sub indoor unit(s), daisy chain using 22 AWG, 3-conductor, twisted, stranded, unshielded. All wiring must comply with all applicable local / national codes.
- (⚠ Do not attach wire to 12VDC terminal to the sub indoor units). All wiring must comply with all applicable local and national codes.
- ⚠ NEVER splice, cut, or extend cable length; always include enough cable to cover distance between all components.

#### For indoor units with CN-REMO connections:

Use one (or multiple) Group Control Kit(s) (sold separately) containing extension and Y-splitter cables. Use one (1) group control cable kit for each indoor unit in the group except for the last indoor unit. ⚠ NEVER splice, cut, or extend cable length with field provided cable.

#### Note:

- Cable connected to zone controller is the factory default connection.
- Indoor unit connections depend on indoor unit type.

#### General Specifications

- Wired remote controllers can be connected to all indoor unit types.
- Wireless controllers can be used in conjunction with wired remote controllers.
- A dry contact unit can be connected with a central controller simultaneously.
  - The main indoor unit is recognized by the dry contact unit and the central controller.
  - Group Control only available for indoor units manufactured after February 2009.
  - The central controller can control indoor units after setting the address of the main indoor unit only.
  - Sub indoor unit cannot be individually controlled by central controller.
  - Sub indoor unit will operate like the main indoor unit.
- If an error occurs with the indoor unit, the error will be displayed on the wired remote controller.
- The following functions are available with group control:
  - Selection of operation options (operation/mode/set temperature)
  - Control of air flow rate (High/Medium/Low)

Figure 100: Example of Indoor Unit Group to Zone Controller Connections (Sig-12V-GND [Comm.] Terminal).

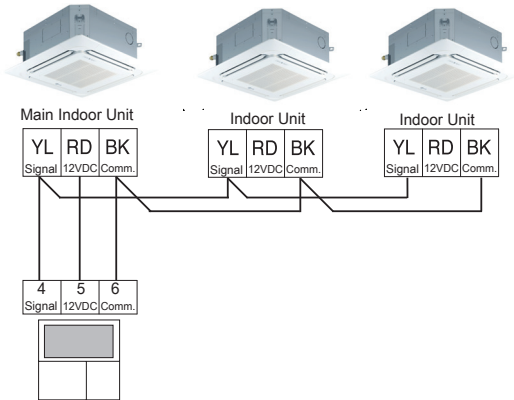


Figure 101: Example of Indoor Unit Group to Zone Controller Connections (CN-REMO).

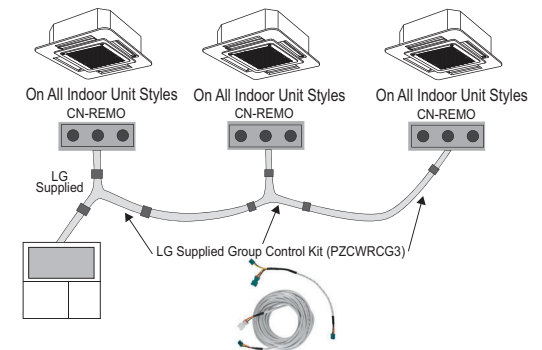


Table 34: Accessories for Some Group Control Applications.

Accessory	Model Number	Image
Wired Remote Group Control Cable Assembly, Required for connecting multiple indoor units to a control group	PZCWRG3	
Wired Remote/Wired Remote Extension Cable, Required for extending the distance between indoor units or remote controllers in a control group	PZCWRC1	

### Triple Leak / Pressure Test

After the refrigerant piping installation is complete, perform a triple leak / pressure test. Triple leak / pressure test is performed between the outdoor unit and indoor units (and branch distribution units [Multi F MAX only]) to verify that refrigerant can flow through the system without danger of leaks or pressure losses. Air and moisture that is left in the piping can lead to undesirable results and can cause damage to the system. It is important to go through a complete leak / pressure cycle to be sure that the refrigerant piping is cleared out. This process will have to be repeated if any air or moisture be is found to remain in the piping.

#### Note:

Insufficient or incorrectly done air purging will lead to the following:

- Pressure in the system can rise.
- Operating current can rise.
- Inefficient cooling or heating mode capability.
- Moisture in the refrigerant circuit will freeze and block capillary tubing.
- Water can lead to corrosion of parts in the system.

#### **⚠ DANGER**

Using combustible gases, including oxygen will result in fire or explosion, resulting in personal injury or death. Use inert gas (medical-grade dry nitrogen) when checking leaks, cleaning, installing/repairing pipes, etc. The use of at least 800 psig nitrogen regulator is required for safety.

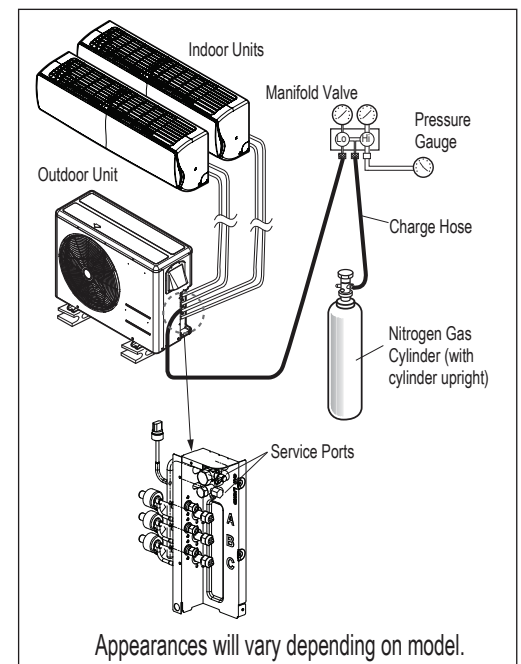
#### Note:

- ⚠ Do not apply power to the system before performing a system leak test. There is a possibility that the EEV valve will close and isolate sections of the piping system, making the leak test inconclusive.
- ⚠ Never perform the leak test using refrigerant.
- To avoid nitrogen entering the refrigerant system in a liquid state, the top of the cylinder must be higher than its bottom (used in a vertical standing position) when the system is pressurized.
- Use only a leak-free gauge manifold set.
- Piping system must not be pressured to more than 550 psi. Pressures greater than 550 psi will damage the piping system and cause unit malfunction.

#### Triple Leak / Pressure Check Procedure

1. After the refrigerant piping installation is complete, open the isolation ball valves, if any, that could have been included in the piping system.
2. Verify that both the liquid and gas (vapor) suction line outdoor unit service ports are closed, and the stem head access caps are tight. The leak / pressure check is to be performed only to the refrigerant piping system, and all connected indoor units and branch distribution units (Multi F MAX units only).
3. Remove the caps on both the liquid and gas (vapor) suction Schrader ports. Connect the (medical-grade dry) nitrogen cylinder regulator to a gauge manifold, then connect the gauge manifold to the Schrader ports on the service ports.
4. Perform the leak / pressure check at 150 psig for fifteen (15) minutes (standing pressure check).
5. Perform the leak / pressure check at 300 psig for thirty (30) minutes (standing pressure check).
6. Perform the leak / pressure check at 550 psig for one (1) hour to make sure the piping system is leak-free. After the gauge reading reaches 550 psig, isolate the system by first closing the gauge manifold, then close the nitrogen cylinder valve. Check the flared (and any brazed connections) for leaks by applying a bubble solution to all joints. Also test for leaks at both service valves.

Figure 102: Triple Leak / Pressure Test Diagram.






# FINAL INSTALLATION PROCEDURES

MULTI F  
MULTI F MAX

## Triple Leak / Pressure and Deep Evacuation Tests

### Triple Leak / Pressure Check Procedure, continued.

**Note:**

The bubble solution must be a solution designed for refrigerant leak testing. Common soap solution must  never be used on refrigerant piping as those contain chemicals that could corrode copper and brass, and cause product malfunction.

7. If the pressure does NOT drop for one (1) hour, the system passes the test.
8. If the pressure drops, there is a leak and it must be found. Remove the bubble solution with a clean cloth, repair the leak(s), and perform the leak / pressure check again.
9. After the system has been thoroughly tested and no leaks are found, depressurize by loosening the charging hose connector at the nitrogen cylinder regulator. When system pressure returns to normal, completely disconnect the charging hose from the cylinder, and release the nitrogen charge from all refrigerant piping. Wipe off any remaining bubble solution with a clean cloth.

### Deep Evacuation Procedure


On Multi F systems, after the leak / pressure check is complete, the deep evacuation procedure must be performed to the refrigerant piping and all connected indoor units. On Multi F MAX systems, the triple evacuation procedure (seen on page 79) must be performed. Deep evacuation must be performed through the Schrader ports on the outdoor unit service ports.

**Note:**



The triple evacuation procedure seen on page 79 is a best practices recommendation for Multi F systems, but mandatory for Multi F MAX systems.

**Note:**

For faster evacuation, the Schrader core can be removed, and an auxiliary service port can be used. Make sure to re-install the original Schrader core before operating the system.

- Deep evacuate through both the liquid and gas (vapor) suction Schrader ports on the outdoor unit service ports.
- The outdoor unit service valves must remain closed and the stem head access caps tight.  Do not open the outdoor unit service valves and release the factory refrigerant charge until trim charge is complete, and the system is ready to operate.
- Any field-installed ball valves in the refrigerant system (if used) must be open to ensure all piping is free and clear for deep evacuation on all piping and connected indoor units.

**Note:**

-  Do not apply power to the system before performing the deep evacuation procedure. There is a possibility that the EEV valve will close and isolate sections of the piping system, making the deep evacuation procedure inconclusive.
-  Never perform evacuation using refrigerant.
- Use only a vacuum pump that can reach 500 microns, vacuum rated hoses or copper tubing, and a leak-free gauge manifold set.
- Use only new vacuum pump oil from a properly sealed (unopened) container, and change oil in pump before EVERY use.
- Subsequent oil changes will be necessary after several hours of continuous operation; have extra oil on hand.
- Use a quality micron gauge in good operating order and install as far away from pump as possible.

### Deep Evacuation Procedure Steps

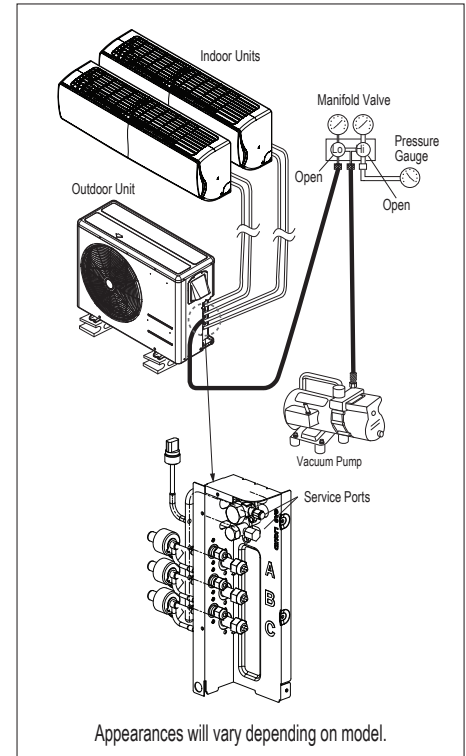
1. If this procedure is performed shortly after the leak / pressure test, the cap and core on the liquid and gas (vapor) suction Schrader ports must have already been removed, and the manifold must already be connected. If the procedure was not performed shortly after the leak / pressure test, make sure to remove the cap and core on the liquid and gas (vapor) suction Schrader ports. Verify that the service valves on the outdoor unit are closed, and the stem head access caps are tight.
2. Connect the gauge manifold along with the vacuum pump to the liquid and gas (vapor) suction Schrader ports (with core removed) using a vacuum hose. Open the gauge manifold and the vacuum pump valves.



### Deep Evacuation Procedure, continued.

3. Evacuate to static micron level  $\leq 500$  for at least one (1) hour.
4. Micron level must remain  $\leq 500$  for two (2) hours. If the vacuum gauge rises and stops, the system could contain moisture; therefore, it will be necessary to repeat the steps of vacuum break and drying.
5. After maintaining the system in vacuum for two (2) hours, check if the vacuum gauge rises or not. If it doesn't rise, then the system is properly evacuated.
6. Close manifold gauges.
7. Shut the valves before turning off and disconnecting the vacuum pump.

Figure 103: Evacuation Procedure Diagram.



### Triple Evacuation Procedure

On Multi F MAX systems, after the leak / pressure check is complete, the triple evacuation procedure must be performed to the refrigerant piping and all connected indoor units / branch distribution units. ⚠ Do not just perform the deep evacuation procedure on Multi F MAX systems. The deep evacuation procedure is insufficient to fully evacuate the extensive piping systems on Multi F MAX products. Triple evacuation must be performed through the Schrader ports on the outdoor unit service ports.

#### Note:

The triple evacuation procedure is a best practices recommendation for Multi F systems, but mandatory for Multi F MAX systems.

#### Note:

For faster evacuation, the Schrader core can be removed, and an auxiliary service port can be used. Make sure to re-install the original Schrader core before operating the system.

- Evacuate through both the liquid and gas (vapor) suction Schrader ports on the outdoor unit service ports.
- The outdoor unit service valves must remain closed and the stem head access caps tight. ⚠ Do not open the outdoor unit service valves and release the factory refrigerant charge until trim charge is complete, and the system is ready to operate.
- Any field-installed ball valves in the refrigerant system (if used) must be open to ensure all piping is free and clear for evacuation on all piping and connected indoor units / branch distribution units.

#### Note:

- ⚠ Do not apply power to the system before performing the evacuation procedure. There is a possibility that the EEV valve will close and isolate sections of the piping system, making the evacuation procedure inconclusive.
- ⚠ Never perform evacuation using refrigerant.
- Use only a vacuum pump that can reach 500 microns, vacuum rated hoses or copper tubing, and a leak-free gauge manifold set.
- Use only new vacuum pump oil from a properly sealed (unopened) container, and change oil in pump before EVERY use.
- Subsequent oil changes will be necessary after several hours of continuous operation; have extra oil on hand.
- Use a quality micron gauge in good operating order and install as far away from pump as possible.

## Triple Evacuation Test


---

---

### Triple Evacuation Procedure Steps

1. If this procedure is performed shortly after the leak / pressure test, the cap and core on the liquid and gas (vapor) suction Schrader ports must have already been removed, and the manifold must already be connected. If the procedure was not performed shortly after the leak / pressure test, make sure to remove the cap and core on the liquid and gas (vapor) suction Schrader ports. Verify that the service valves on the outdoor unit are closed, and the stem head access caps are tight.
2. Connect the gauge manifold along with the vacuum pump to the liquid and gas (vapor) suction Schrader ports (with core removed) using a vacuum hose. Open the gauge manifold and the vacuum pump valves.

#### Note:

- After the vacuum pump is first operated, if hoses, manifold, and vacuum valves are leak free (and oil is not moisture laden), the gauge must read <100 microns within one (1) minute.
-  Do not proceed if the gauge does not read <100 microns within one (1) minute. There is a leak in the hose, gauge manifold, or vacuum valve, and the equipment must be replaced.

3. Operate the vacuum pump and evacuate the system to the 2,000 micron level. Isolate the pump by closing the manifold gauges and the vacuum pump valve, and then watch the micron level. Micron level will rise a bit, but MUST eventually stop rising for fifteen (15) minutes.
  - If the micron level DOES NOT stop rising, there is a leak, and the leak test must be performed again.
  - If the micron level DOES rise above 2,000 micron, re-open the manifold gauges and the vacuum pump valve and continue evacuation back down to 2,000 micron level.
  - If the micron level holds at 2,000 micron, continue to step 4.
4. Break vacuum with 50 psig nitrogen purge for an appropriate amount of time (this is to “sweep” moisture from piping).
5. Purge nitrogen from the system until the pressure drops down to 1 to 3 psig.
6. Evacuate to 1,000 micron level. Isolate the pump by closing the manifold gauges and the vacuum pump valve, and then watch the micron level. Micron level will rise a bit, but MUST eventually stop rising for fifteen (15) minutes.
  - If the micron level DOES NOT stop rising, there is a leak, and the leak test must be performed again.
  - If the micron level DOES rise above 1,000 micron, re-open the manifold gauges and the vacuum pump valve, and continue evacuation back down to 1,000 micron level.
  - If the micron level holds at 1,000 micron, continue to step 7.
7. Break vacuum with 50 psig nitrogen purge for an appropriate amount of time.
8. Purge nitrogen from the system until the pressure drops down to 1 to 3 psig.
9. Evacuate to static micron level  $\leq 500$  for at least one (1) hour.
10. Micron level must remain  $\leq 500$  for one (1) hour. If the vacuum gauge rises and stops, the system could contain moisture; therefore, it will be necessary to repeat the steps of vacuum break and drying.
11. After maintaining the system in vacuum for one (1) hour, check if the vacuum gauge rises or not. If it doesn't rise, then the system is properly evacuated.
12. Close manifold gauges.
13. Shut the valves before turning off and disconnecting the vacuum pump.

LG Multi F and Multi F MAX outdoor units ship from the factory with a charge of R410A refrigerant. A trim charge will need to be added to take into account additional piping length.

To determine the additional refrigerant that is needed, apply the formulas below, and record the results. If the total additional refrigerant charge value is a negative number, then an additional trim charge does not need to be added to the system.

Table 35: Outdoor Unit Factory Charge.

Outdoor Unit	Factory Charge lbs. of R410A
LMU180HV	3.97
LMU18CHV	3.96
LMU240HV	3.97
LMU24CHV	3.96
LMU30CHV	6.18
LMU36CHV	6.18
LMU480HV	9.7
LMU540HV	9.7
LMU600HV	12.3

### Multi F Systems

$$\begin{aligned} \text{Additional charge (lbs.)} = & (\text{Installed Length of Branch [A]} - \text{Chargeless Pipe Length [L]}) \times a \\ & + (\text{Installed Length of Branch [B]} - \text{Chargeless Pipe Length [L]}) \times a \\ & + (\text{Installed Length of Branch [C]} - \text{Chargeless Pipe Length [L]}) \times a \\ & + (\text{Installed Length of Branch [D]} - \text{Chargeless Pipe Length [L]}) \times a \\ & - \text{CF (Correction Factor)} \times 5.29 \end{aligned}$$

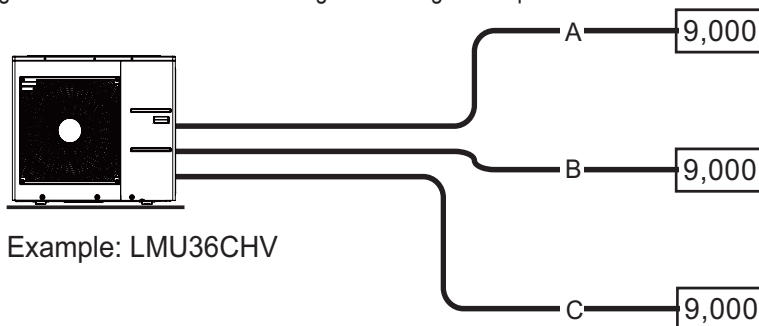
#### Note:

- Number of installed length of branches depends on the specifications of the outdoor unit model.
- CF = Maximum number of connectible indoor units – Total number of connected indoor units.

Table 36: Multi F Outdoor Unit Piping Specifications.

Outdoor Unit Model	Min. to Max. Piping Length for One Branch (ft.)	Max. Total System Piping Length (ft.)	Chargeless Pipe Length per Branch (L) (ft.)	Piping Length (No Additional Refrigerant [ft])	Additional Charge Needed (a) (oz./ft.)
LMU180HV	9.8 to 82	164	24.6	98.4	0.22
LMU18CHV	9.8 to 82	164	24.6	49.2	0.22
LMU240HV	9.8 to 82	230.0	24.6	98.4	0.22
LMU24CHV	9.8 to 82	246.1	24.6	73.8	0.22
LMU30CHV	9.8 to 82	246.1	24.6	98.4	0.22
LMU36CHV	9.8 to 82	246.1	24.6	98.4	0.22

Figure 104: Multi F Additional Refrigerant Charge Example.



Each branch pipe  
A = 82 ft.  
B = 16 ft.  
C = 49 ft.

$$\begin{aligned} \text{Additional Charge} &= (82 - 24.6) \times 0.22 \\ &+ (16 - 24.6) \times 0.22 \\ &+ (49 - 24.6) \times 0.22 \\ &- (4 - 3) \times 5.29 \\ &= 10.82 \text{ oz.} \end{aligned}$$

# FINAL INSTALLATION PROCEDURES

## Refrigerant Charge

MULTI F  
MULTI F MAX

### Multi F MAX Systems

Additional charge (lbs.) = (Total Main Piping Length [A] - Chargeless Pipe Length of Main Pipe [L]) x a  
 + (Installed Length of Branch [B1] - Chargeless Pipe Length [B]) x b  
 + (Installed Length of Branch [B2] - Chargeless Pipe Length [B]) x b  
 + (Installed Length of Branch [B3] - Chargeless Pipe Length [B]) x b ...  
 - CF (Correction Factor) x 3.53

#### Note:

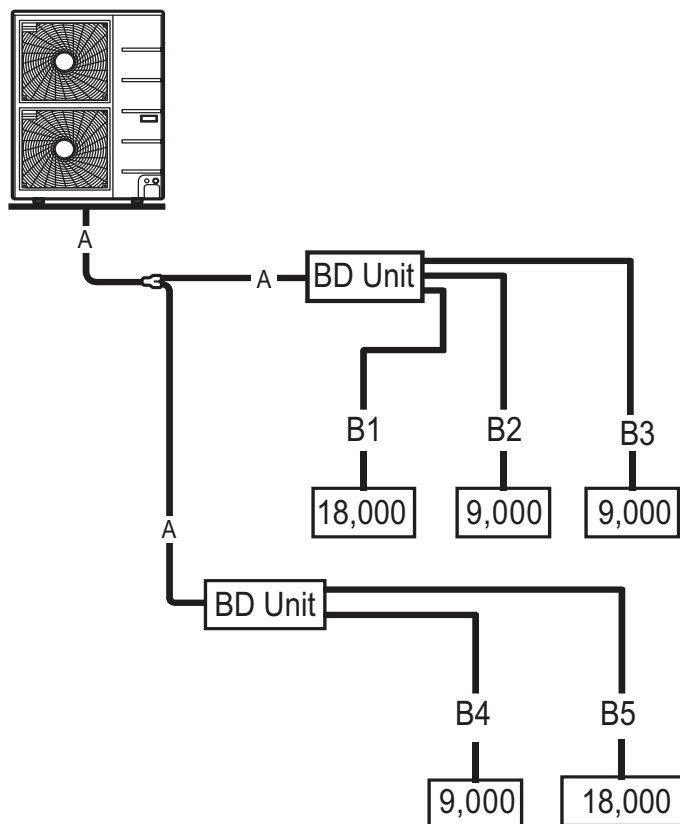
- Number of installed length of branches depends on system specifications.
- CF = Maximum number of connectible indoor units - Total number of connected indoor units

Table 37: Multi F MAX Outdoor Unit Piping Specifications.

Outdoor Unit Model	Main Piping Length		Branch Piping Length	
	Chargeless Pipe Length of Main Pipe (L) (ft.)	Additional Charge Needed (a) (oz./ft.)	Chargeless Pipe Length per Branch Pipe (B) (ft.)	Additional Charge Needed (b) (oz./ft.)
LMU480HV	16.4	0.54	16.4	0.22
LMU540HV	16.4	0.54	16.4	0.22
LMU600HV	16.4	0.54	16.4	0.22

Figure 105: Multi F MAX Additional Refrigerant Charge Example.

LMU420HV



- Total main pipe (A) = 60 ft.
- Each branch pipe  
 B1 = 49 ft.  
 B2 = 17 ft.  
 B3 = 17 ft.  
 B4 = 10 ft.  
 B5 = 23 ft.

Additional Charge  
 = (60 - 16.4) x 0.54  
 + (49 - 16.4) x 0.22  
 + (17 - 16.4) x 0.22  
 + (17 - 16.4) x 0.22  
 + (10 - 16.4) x 0.22  
 + (23 - 16.4) x 0.22  
 - (8 - 5) x 3.53  
 = 20.43 oz.

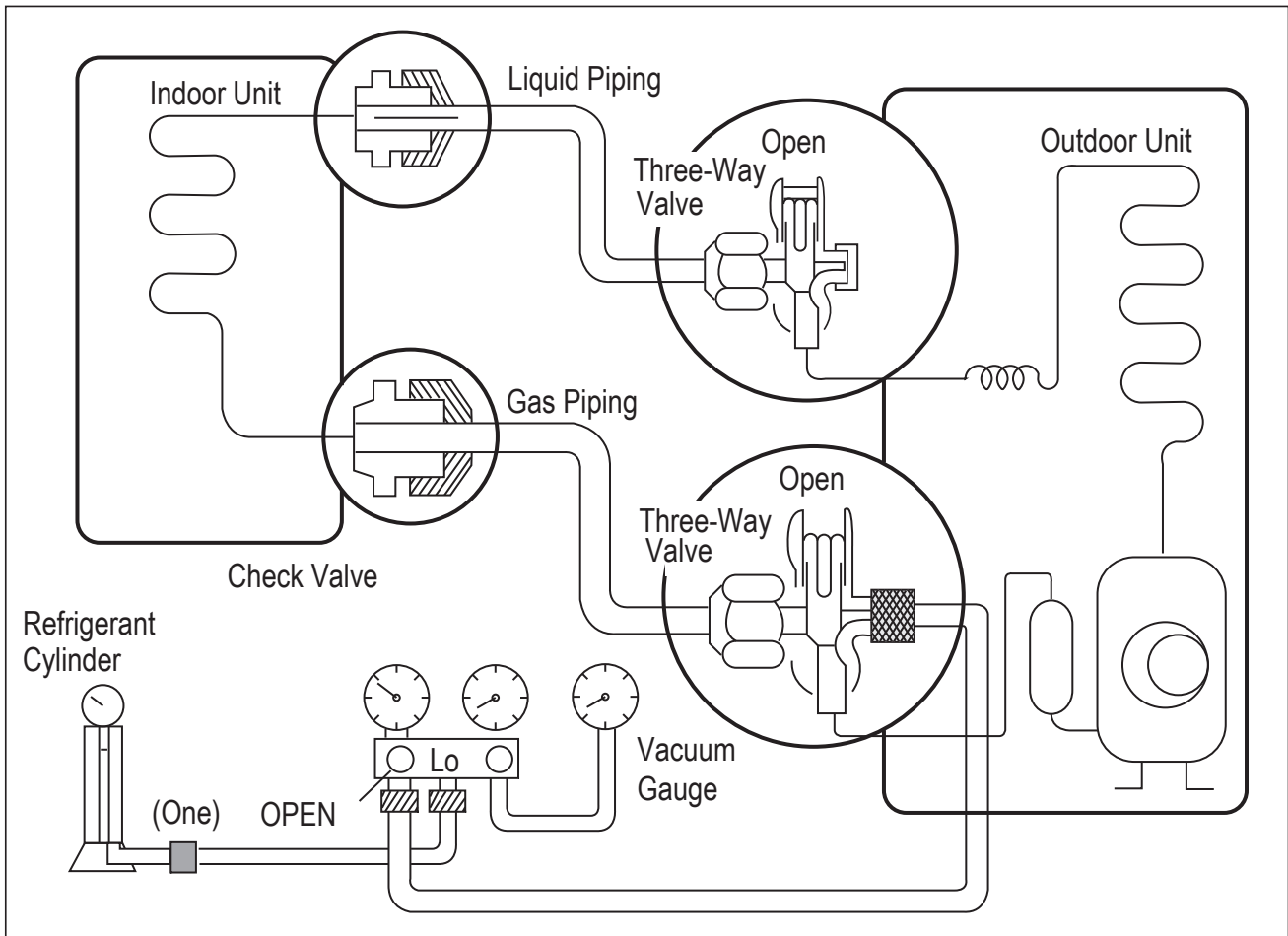
### Refrigerant Charge

1. Determine the refrigerant that is needed, applying the necessary formulas as outlined in the previous pages.
2. Connect the charging cylinder to the charge hose on the manifold valve.
3. Purge air from the charge hose by opening the valve at the bottom of the cylinder, and press the check valve on the manifold valve.
4. Confirm that the "Lo" knob of the manifold valve is open and charge the system with liquid refrigerant. (Because R-410A is a non-azeotrope refrigerant, it must be charged in the liquid state.)
  - If the required amount of refrigerant cannot be charged all at once, the refrigerant can be charged a little at a time (approximately 5.29 ounces) while the system operates in cooling. This procedure must be repeated until the entire amount of refrigerant gets charged into the system; perform once, then wait approximately one [1] minute before resuming.
5. Immediately disconnect the charge hose from the service port on the three-way valve. Stopping halfway allows the refrigerant to discharge.
  - If the system has been charged with liquid refrigerant while it operates, turn the system off before disconnecting the hose.
6. Mount the valve stem nuts and the service port nut. Use torque wrench to tighten the service port nut to a torque of 1.8 kg.m and check for leaks.

#### ⚠ WARNING

When installing or relocating the outdoor unit, make sure that no substance other than the specified refrigerant (R410A) enters the refrigerant circuit. The presence of foreign substances such as air can cause an abnormal pressure rise and will result in explosion and physical injury.

Figure 106: Charging the Refrigerant.



## Cautions for Refrigerant Leaks

### Cautions for Refrigerant Leaks / Introduction

ASHRAE Standards 15 and 34 offer guidelines that address refrigerant safety and the maximum allowable concentration of refrigerant in an occupied space. Refrigerant will dissipate into the atmosphere, but a certain volume of air is required for this to occur safely. For R410A refrigerant, the maximum allowable concentration is 0.026 lbs./ft<sup>3</sup> per 1,000 ft<sup>3</sup> of air in an occupied space. Buildings with twenty-four (24) hour occupancy allow half of that concentration.<sup>1</sup>

ASHRAE Standards 15 and 34 assume that if a system develops a leak, its entire refrigerant charge will dump into the area where the leak occurs. To meet ASHRAE Standards 15 and 34, calculate the refrigerant concentration that will occur in the smallest room volume on the system, and compare the results to the maximum allowable concentration number (see below for information on how to calculate the refrigerant concentration).<sup>1</sup> Also consult state and local codes in regards to refrigerant safety.

#### **⚠ WARNING**

Verify the maximum refrigerant concentration level in the space where the indoor unit will be mounted meets the concentration limit for the application. If the refrigerant leaks and safety limits are exceeded, it could result in personal injuries or death from oxygen depletion.

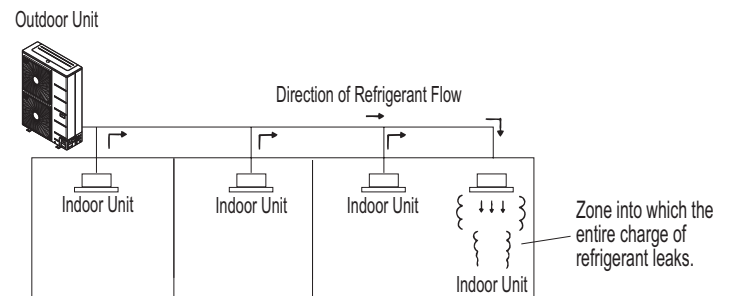
#### **Note:**

Take appropriate actions at the end of HVAC equipment life to recover, recycle, reclaim or destroy R410A refrigerant according to applicable US EPA rules.

To calculate the potential refrigerant concentration level (RCL):

1. Measure the occupied space dimensions (in feet).
2. Calculate the cubic foot volume of air in the smallest occupied space. (To obtain a detailed overview of the RCL, perform the same calculations to the second smallest zone, the third smallest zone until the RCL is obtained for all zones. Also, pay special attention to areas such as basements, etc., where refrigerant cannot dissipate easily.)
3. Divide the refrigerant charge of the Multi Zone system serving the area in pounds by the results of step 1.
4. If the calculation indicates that the potential refrigerant concentration level is higher than the allowed RCL, increase the cubic volume of the smallest occupied space or modify the piping system design.
5. The allowable RCL limit for most applications must be equal to or less than 0.026 lbs./ft<sup>3</sup>. However, in special occupied spaces, such as hospitals and nursing homes, where occupants will have limited mobility, the allowable RCL limit is cut in half. See ASHRAE Standard 34 and local codes for detailed information.<sup>1</sup>

Figure 107: Example of R410A Refrigerant Leak Location.



### Refrigerant Concentration Limit (RCL) Calculations

To calculate total refrigerant amount per system:

<b>Amount of Factory-Charged Refrigerant per Outdoor Unit</b>	<b>+</b>	<b>Amount of Additional Refrigerant Trim Charge</b>	<b>=</b>	<b>Total System Refrigerant Charge</b>
---	----------	---	----------	--

$$\text{RCL (lbs./ft}^3\text{)} = \frac{\text{Total System Refrigerant Charge (lbs.)}}{\text{Volume of Smallest Occupied Space (ft}^3\text{)}}$$

<sup>1</sup>American Society of Heating, Refrigeration and Air Conditioning Engineers, Inc. (ASHRAE). Atlanta, GA. ASHRAE, Inc. Information about ASHRAE Standard 15 / 34 and addenda current as of the date of this publication.



To determine the volume of an occupied space, the designer must also determine which ones are connected, not connected, or ventilated (refer to Standard 34).

If the calculated RCL is above the allowable limit, there are two primary methods used to lower the RCL:

1. Increase the volume of the occupied space.
2. Decrease the size of the refrigerant charge.

Per Standard 34-2007, acceptable methods used to increase the volume of an occupied space include:

- Install transfer ducts between rooms.
- Undercut and overcut doors (partitions  $\leq 0.15\%$  of cubic volume of space within a zone).
- Add an opening without a door (partitions  $\leq 0.15\%$  of cubic volume of space within a zone).
- Include ventilation grilles in doors; include ventilation inlets / outlets (partitions  $\leq 0.15\%$  of cubic volume of space within a zone).
- Include the area above the ceiling as part of the return or supply air path (partitions  $\leq 0.15\%$  of cubic volume of space within a zone).
- Install a mechanical ventilator linked to a gas leak detector.
- Change the indoor unit type (wall mounted to ceiling cassette) / position.

Figure 108: Examples of Zones.

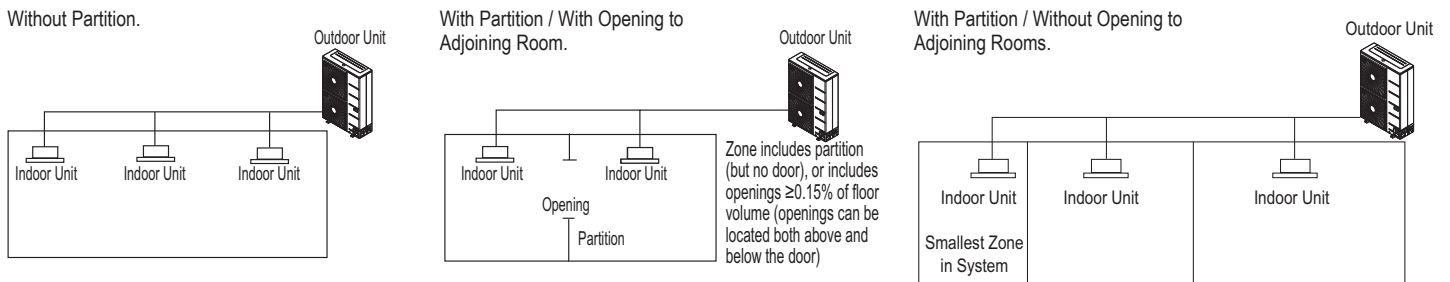
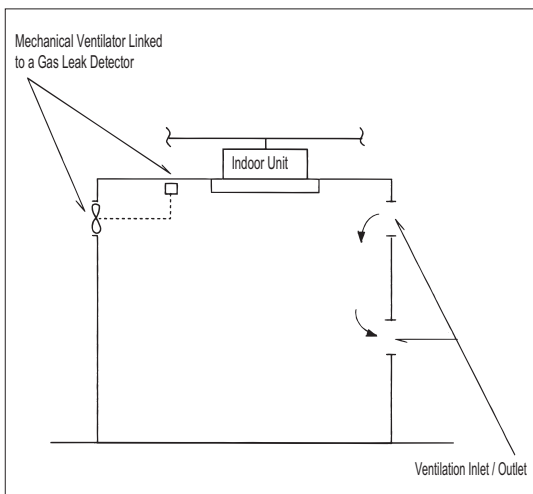


Figure 109: Example of Acceptable Ventilation Methods.



**Note:**

See also the LG HVAC Building Ventilation Guide on [www.lghvac.com](http://www.lghvac.com).

## Test Run

### Test Run

After the triple leak / pressure and evacuation procedures are complete, perform a test run.

### Before the Test Run

1. Check that all condensate tubing, refrigerant piping and power wiring, and communication / connection (power) cables are properly connected.
2. Make sure that the gas and liquid service valves are fully open.

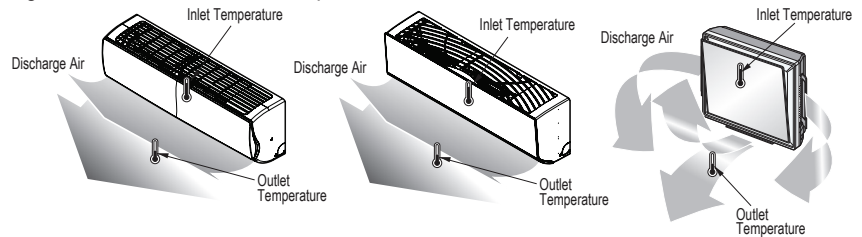
### Test Run Procedure

1. Operate the system in cooling mode for 15 to 20 minutes.
2. Evaluate performance as the system runs, verifying the outdoor unit, and all indoor units and branch distribution units (Multi F MAX systems only) are working properly. Make notes as needed to address any issues that might be found.
  - Check the system refrigerant charge:
    - Measure the pressure from the gas side service valve.
    - Measure the indoor unit inlet and outlet air temperatures. Verify the difference between the intake temperature and the discharge is more than 15°F.
    - See table below for the optimum condition of the gas side pressure (again, system is in cooling mode).

Table 38: Optimum Conditions of the Gas Side Pressure.

Refrigerant Type	Outside Ambient Temperature	Gas Side Service Valve Pressure
R410A	95°F	113~142 psig

Figure 111: Inlet and Outlet Temperature Locations on Various Indoor Units.



### Note:

If the pressure is >142 psig, the system is most likely overcharged, and refrigerant must be removed. If the pressure is <113 psig, the system is most likely undercharged and refrigerant must be added.

### Installing the Remote Controller Batteries

As part of the test run, the batteries need to be inserted into the remote controller, and the remote controller will need to be powered on to operate the indoor units (depending on the indoor units included in the system). To insert the batteries, follow the steps below. For information on using the remote controller, refer to its owner's manual.

1. The remote controller needs two (2) AAA (1.5V) batteries for operation. ⚠ Do not use rechargeable batteries. Remove the battery cover from the back of the remote controller by pushing downward on the tab at the top of the battery cover and then lift up to remove.
2. Insert the two new batteries. Align batteries by the (+) and (-) sides (the interior battery compartment of the remote controller will have clear markings for the (+) and (-) placement).
3. Verify that the batteries have "clicked" into the compartment and are firmly engaged with the contacts on either side.
4. Reattach the back cover of the remote controller.
5. Proceed with powering on the remote controller and usage as needed.

Figure 112: Installing the Remote Controller Batteries.

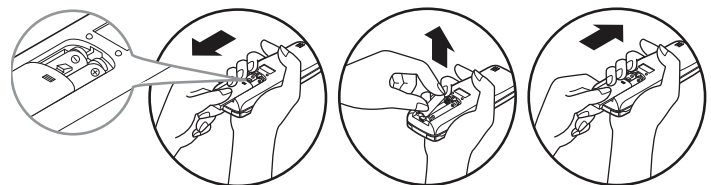
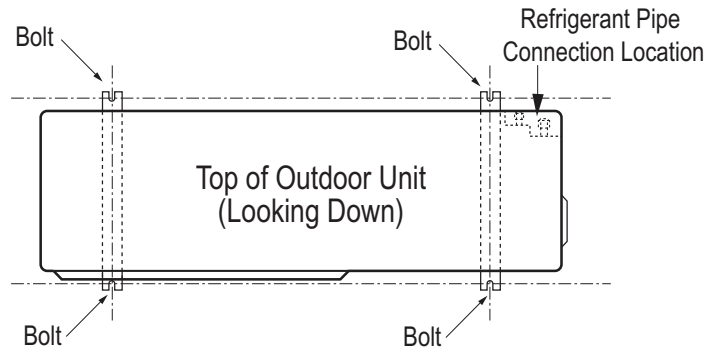


Figure 110: Piping Connection on the Outdoor Unit (Will Differ Depending on Outdoor Unit Model).



### Outdoor Unit DIP Switch Settings

System must be powered off, and then turned back on to apply DIP switch settings.

#### ⚠ WARNING

Turn off the circuit breaker or shut off the power source of the product before setting the DIP switch. There is risk of physical injury or death due to electric shock.

#### Note:

- Unless the applicable DIP switch is set properly, the system will not work.
- If a specific function is desired, request that the installer set the appropriate DIP switch during installation.
- Only the first four DIP switches are used to set settings and functions.

Table 39: DIP Switch Settings and Functionalities.

DIP Switch Setting	Function
	Normal Operation (No Function)
	Forced Cooling Operation
	Wiring Error Check
	Reducing Power Consumption (Step 1)
	Reducing Power Consumption (Step 2)
	Mode Lock (Cooling)
	Mode Lock (Heating)
	Night Quiet Mode (Step 1)
	Night Quiet Mode (Step 2)
	Mode Lock (Cooling) + Night Quiet Mode (Step 1)
	Mode Lock (Cooling) + Night Quiet Mode (Step 2)
	Reducing Power Consumption (Step 1) with Mode Lock (Cooling)
	Reducing Power Consumption (Step 2) with Mode Lock (Cooling)
	Reducing Power Consumption (Step 1) with Mode Lock (Heating)
	Reducing Power Consumption (Step 2) with Mode Lock (Heating)

Figure 113: LMU18CHV~36CHV, Outdoor Unit DIP Switches (in Normal Operation Setting).

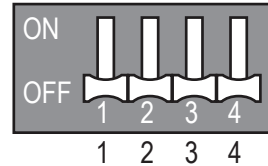


Figure 114: LMU180~240HV, LMU480~540HV Outdoor Unit DIP Switches (in Normal Operation Setting).

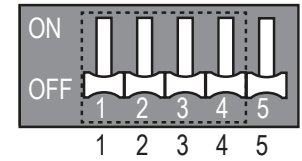
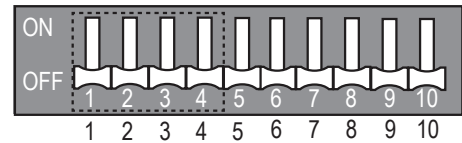


Figure 115: LMU600HV Outdoor Unit DIP Switches (in Normal Operation Setting).



# FINAL INSTALLATION PROCEDURES

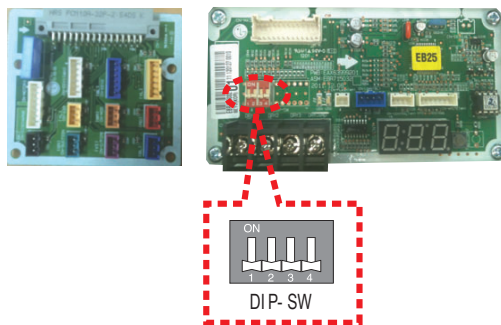
## DIP Switch Settings for Optional Modes

MULTI F  
MULTI F MAX

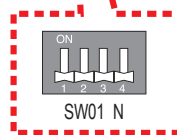
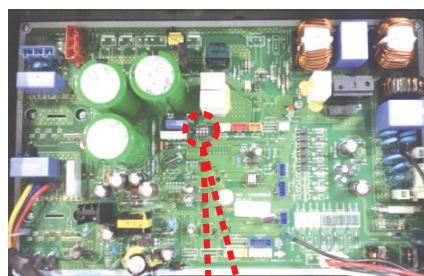
### Location of DIP Switches on Multi F and Multi F MAX Outdoor Units

Figure 116: Multi F / Multi F MAX Outdoor Unit DIP Switch Locations (Will Vary in Appearance Depending on Model).

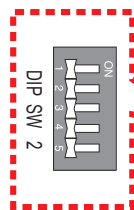
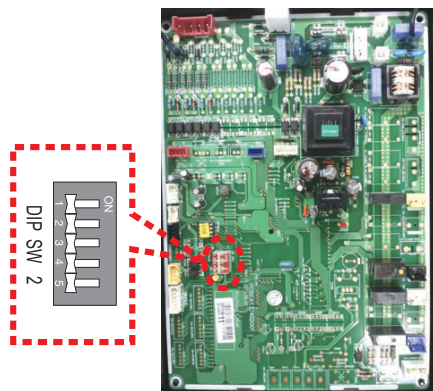
Multi F LMU18\*HV and LMU24\*HV



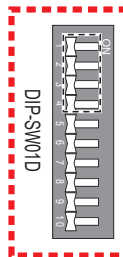
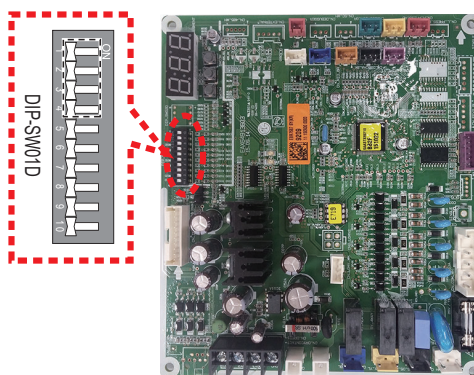
Multi F LMU30CHV and LMU36CHV



Multi F MAX LMU480HV and LMU540HV



Multi F MAX LMU600HV



### Forced Cooling Operation Function

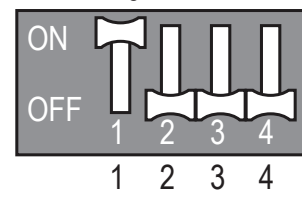
Use to add refrigerant to the system when outside ambient temperatures are cool (ex.: winter).

1. Shut power down to the system.
2. Set DIP Switch 1 to ON.
3. Turn power on to the system.
4. Verify that the Red LED on the outdoor unit PCB is ON (indicates indoor units are in forced cooling operation).
5. Add refrigerant.

#### Note:

- If the green LED light on the outdoor unit PCB is ON, it indicates the compressor is OFF due to low pressure in the system.
- Turn DIP Switch 1 to OFF after finishing (Normal Operation setting).
- Only the first four DIP switches are used to set settings and functions.

Figure 117: Forced Cooling DIP Switch Setting.



### Wiring Error Check

Use to verify if wiring is properly installed.

1. Shut power down to the system.
2. Set DIP Switch 2 to ON.
3. Turn power on to the system.
4. Check if the Red and Green LEDs on the outdoor unit PCB are ON (indicate indoor units are in forced operation mode).
5. If the wiring is correctly installed, the Green LED will light up. If the wiring is incorrectly installed, the Red and Green LEDs will blink, indicating which part of the system is in error.
  - Red LED = Piping Number
  - Green LED = Wiring Number (Room)

Example: If the Red LED blinks twice and the Green LED blinks three times, the second piping to the third room is in error (see at right).

#### Note:

- If the indoor unit(s) are not communicating properly to the outdoor unit, the Wiring Error Check cannot operate correctly.
- Only the part of the system in error will be displayed. System will operate correctly after the error is fixed.
- If outdoor and indoor temperatures are too low (ex.: winter), the wiring error check function will not operate (Red LED is ON).
- Turn DIP Switch 2 to OFF after finishing (Normal Operation setting).
- Only the first four DIP switches are used to set settings and functions.

Figure 118: Wiring Error Check DIP Switch Setting.

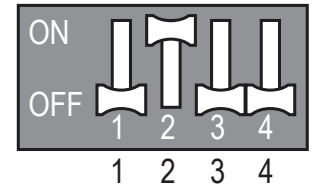
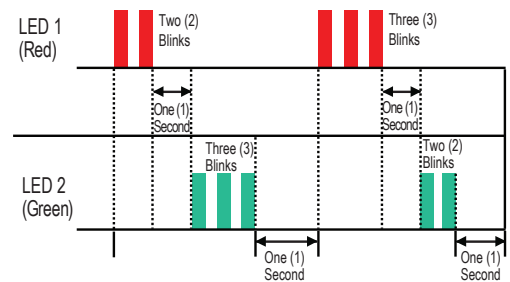


Figure 119: Wiring Error Check Example.



### Reducing Power Consumption

Enables more efficient system operation by reducing the maximum power consumption value (reducing the MCA).

1. Shut power down to the system.
2. For Step 1, set only DIP Switch 3 to ON. For Step 2, set only DIP Switch 4 to ON.
3. Turn power on to the system.

Figure 120: Reducing Power Consumption Chart.

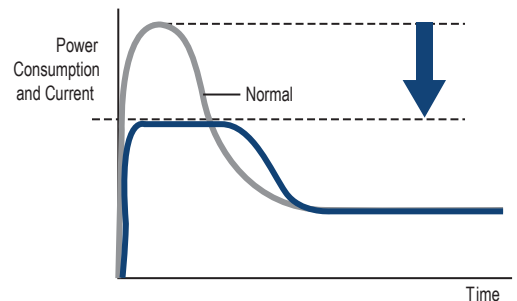
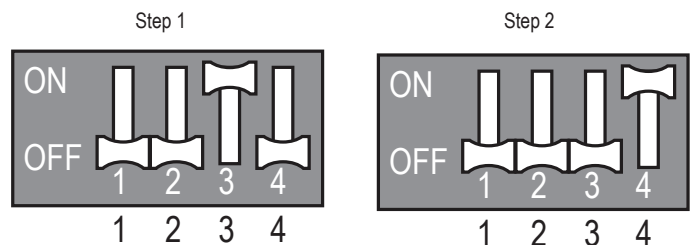


Table 40: Reducing Power Consumption Current Levels.

Phase	1Ø		
Model	Multi F LMU18*HV, LMU24*HV	Multi F LMU30CHV, LMU36CHV	Multi F MAX LMU480HV, LMU540HV, LMU600HV
Step 1 (A)	9	13	22
Step 2 (A)	8	11	21

Figure 121: Reducing Power Consumption DIP Switch Settings.



#### Note:

- Reduced Power Consumption reduces outdoor unit capacity.
- Only the first four DIP switches are used to set settings and functions.



## DIP Switch Settings for Optional Modes

### Reducing Power Consumption with Mode Lock

Enables more efficient system operation by lowering the maximum power consumption value, as well as locks the mode of operation (Example: In a cooling-only server room application where permission to adjust the system mode is highly limited). Changing modes can cause a change in compressor frequency, which would cause problems with the setting. As such, if this mode is used, it is locked in either cooling or heating. The function is rarely, if ever, used.

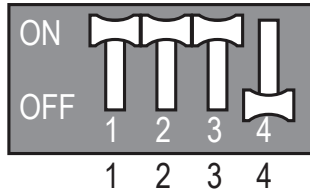
1. Shut power down to the system.
2. Set DIP Switches as indicated below, following the steps and chosen mode.
3. Turn power on to the system.

**Note:**

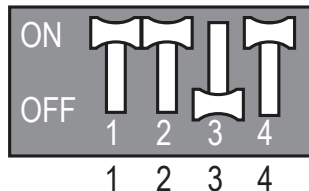
Only the first four DIP switches are used to set settings and functions.

Figure 122: Saving Power Consumption with Mode Lock DIP Switch Settings.

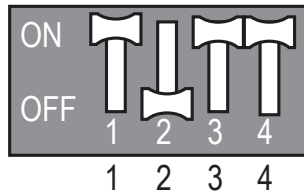
Step 1: Reducing Saving Power Consumption + Mode Lock (Cooling)



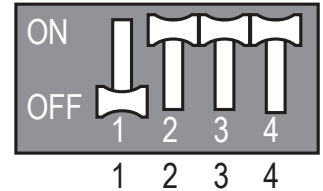
Step 2: Reducing Saving Power Consumption + Mode Lock (Cooling)



Step 1: Reducing Saving Power Consumption + Mode Lock (Heating)



Step 2: Reducing Saving Power Consumption + Mode Lock (Heating)

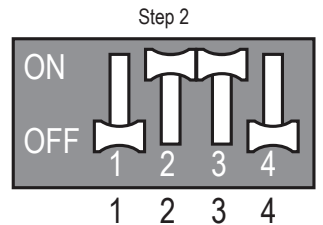
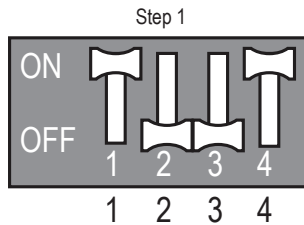


### Night Quiet Mode

Lowest the operation sound of the outdoor unit by changing the compressor frequency and fan speeds. Night quiet mode initiates eight (8) hours after the highest outdoor air temperature is measured, then is active for nine (9) hours.

1. Shut power down to the system.
2. For Step 1, set only DIP Switches 2 and 3 to ON. For Step 2, set only DIP Switches 1 and 4 to ON.
3. Turn power on to the system.

Figure 123: Night Quiet Mode DIP Switch Settings.



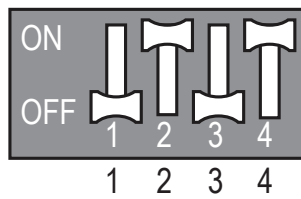
### Night Quiet Mode with Mode Lock

Lowest the operation sound of the outdoor unit by changing the compressor frequency and fan speeds, as well as locks the mode of operation. Changing modes can cause a change in compressor frequency, which would cause problems with the setting. As such, if this mode is used, it is locked in either cooling or heating. The function is rarely, if ever, used. Night quiet mode initiates eight (8) hours after the highest outdoor air temperature is measured, then is active for nine (9) hours.

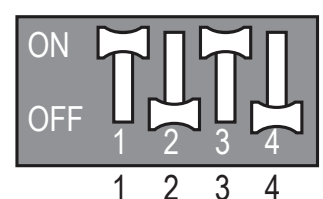
1. Shut power down to the system.
2. For Step 1, set only DIP Switches 2 and 4 to ON. For Step 2, set DIP Switches 1 and 3 to ON.
3. Turn power on to the system.

Figure 124: Night Quiet Mode with Mode Lock DIP Switch Settings.

Step 1: Night Quiet Mode + Mode Lock (Cooling)



Step 2: Reducing Saving Power Consumption + Mode Lock (Cooling)



**Note:**

- If compressor frequency and fan speed are decreased, cooling capacity also will decrease accordingly.
- Night Quiet Mode can only be used when system is in cooling operation.
- Change the DIP switches if Night Quiet Mode is no longer desired.
- If indoor unit operation is set by the fan speed "Power", Night Quiet Mode will not function until fan speed "Power" is changed.
- Only the first four DIP switches are used to set settings and functions.



### Mode Lock

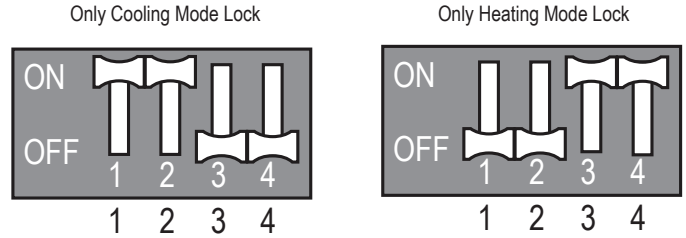
Prevents mixed mode operation (mode change) in applications where only one mode is necessary.

1. Shut power down to the system.
2. For Only Cooling Mode Lock, set only DIP Switches 1 and 2 to ON. For Only Heating Mode Lock, set only DIP Switches 3 and 4 to ON.
3. Turn power on to the system.

### Note:

Only the first four DIP switches are used to set settings and functions.

Figure 125: Mode Lock DIP Switch Settings.



### PCB Display (Multi F LMU18-24\*HV and LMU600HV Models Only)

For Multi F LMU18\*HV, LMU24\*HV, and LMU600HV outdoor units, the cycle data can be checked without using LG Monitoring View (LGMV) Diagnostic Software by pushing TACT-SW1. See below for the types of cycle information that will be displayed in LGMV. After first page is displayed, the second page will be subsequently displayed.

### ⚠ WARNING

Protect fingers / hands with a non-conducting material before pushing TACT-SW1. There is risk of physical injury or death due to electric shock.

Figure 126: Location of TACT-SW1 (LMU18-24\*HV).



Figure 127: Location of TACT-SW1 (LMU600HV).

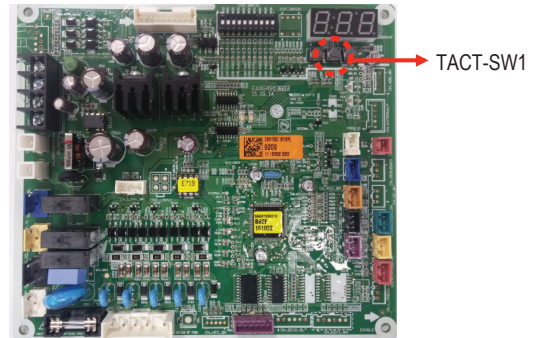


Table 41: PCB Display Information.

TACT-SW1 No. of Pushes	Description	Display		
		Example	First Page	Second Page
One (1) Time	Low Pressure	890kpa	"LP"	"89"
Two (2) Times	High Pressure	2,900kpa	"HP"	"290"
Three (3) Times	Discharge Temperature	85°C	"DS"	"85"
Four (4) Times	Condenser Outlet Temperature	-10°C	"CS"	"-10"
Five (5) Times	Suction Temperature	-10°C	"SS"	"-10"
Six (6) Times	Outdoor Unit Air Temperature	-10°C	"AS"	"-10"
Seven (7) Times	Current	15A	"A"	"15"
Eight (8) Times	Voltage	230V	"V"	"230"
Nine (9) Times	Compressor Hz	100Hz	"F"	"100"
Ten (10) Times	DC Link Voltage	230V	"dc"	"230"



**WARNING** Please refer to the Safety Precautions on pages 4-7 for more detail to prevent injury or death regarding the operation and service troubleshooting of the Multi F / Multi F MAX product.

## Troubleshooting Using Error Codes

Refer to the tables below and on the next page for error codes that are generated from the indoor and outdoor units. These codes indicate different types of unit failures, assist in self-diagnosis, are the most common that will manifest through these units. Error codes are displayed on indoor unit LEDs, wired remote controllers, the outdoor unit PCB, and through LG Monitoring View (LGMV) diagnostic software.

Systems could generate additional codes not listed here. Contact LG Support if these types of errors are seen and a simple power down and boot up has not corrected the issue. ⚠ Do not attempt to fix the system yourself.

- If two or more errors occur simultaneously, the highest error code number is displayed first.
- After error is resolved, the error code does not display.

### Decoding the Error Display

See images and table below for indoor unit error codes, location of LEDs, and operation status.

The first and second number on the LED indicates error number. Example: 21 = LED1 (Red light) 2x blink, LED2 (Green light) 1x blink.

### Error Code Nomenclature Definitions

- MICOM: Non-volatile memory chip where unit setup information is stored.
- EEPROM: Non-volatile memory chip where device identification, size, and factory defined default component operating parameters are stored.

Figure 128: Example of Standard Wall-Mounted Indoor Unit LEDs.

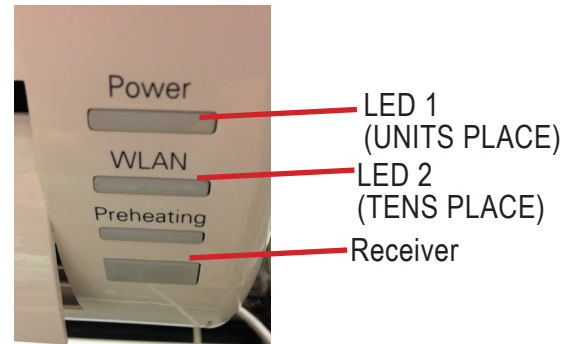


Figure 129: Example of Art Cool Mirror Wall-Mounted Indoor Unit LEDs.

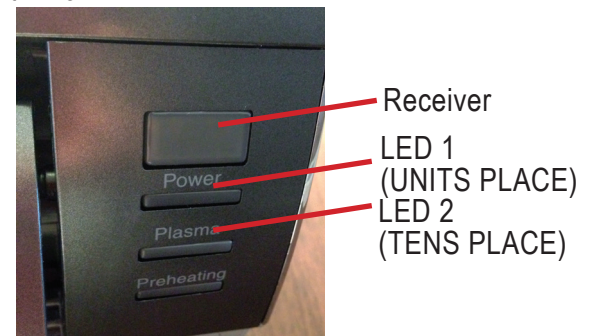
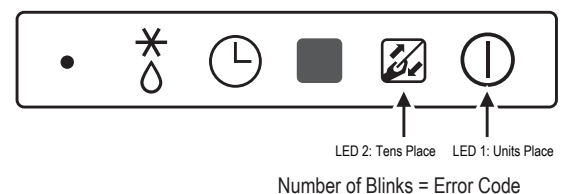


Figure 130: Example of Ceiling Cassette Indoor Unit LEDs.



### Note:

Appearances will vary depending on model.

Table 42: Indoor Unit Error Codes.

Error Code	Description	Indoor Unit Operation Status
00	No error	ON
01	Indoor unit room temperature sensor error	OFF
02	Indoor unit inlet pipe sensor error	OFF
03	Controller error	OFF
04	Drain pump error (optional)	OFF
05	Communication error between indoor unit and outdoor units	OFF
06	Indoor unit outlet pipe sensor error	OFF
07	Different mode operation error	OFF
09	Indoor unit EEPROM error	OFF
10	Indoor unit BLDC motor fan lock	OFF



**WARNING** Please refer to the Safety Precautions on pages 4-7 for more detail to prevent injury or death regarding the operation and service troubleshooting of the Multi F / Multi F MAX product.

Table 43: Outdoor Unit Error Codes.

Error Code	Description	No. of Times Outdoor Unit LEDs Blink		Outdoor Operation Status
		LED01 (Red)	LED02 (Green)	
21	DC Peak (IPM Fault); Compressor DC voltage was too high	2X	1X	OFF
22	Current Transformer2 (CT2) error; Alternating current (AC) input too high	2X	2X	OFF
23	DC Link Low Voltage (DC Link Voltage is <140VDC)	2X	3X	OFF
	DC Link High Voltage (DC Link Voltage is >420VDC)			
25	AC Low / High Voltage	2X	5X	OFF
26	DC Compressor Position Error (Compressor failed to start properly)	2X	6X	OFF
27	PSC / PFC Fault; Input current to inverter compressor PCB is too high	2X	7X	OFF
29	Current to inverter compressor is too high	2X	9X	OFF
32	Inverter compressor discharge pipe (D-Pipe) temperature is too high	3X	2X	OFF
35	Low Pressure Error; Pressure dropped below recommended limits	3X	5X	OFF
39	Communication Error between PFC MICOM and Inverter MICOM	3X	9X	OFF
40	CT Sensor Error; Thermistor is disconnected or has shorted out	4X	-	OFF
41	Inverter compressor discharge pipe (D-Pipe) sensor is disconnected or has shorted out	4X	1X	OFF
43	High pressure sensor is disconnected or has shorted out	4X	3X	OFF
44	Outdoor air sensor is disconnected or has shorted out	4X	4X	OFF
45	Mid-pipe thermistor of outdoor unit condenser is disconnected or has shorted out	4X	5X	OFF
46	Outdoor unit suction piping thermistor is disconnected or has shorted out	4X	6X	OFF
48	Outlet piping (liquid) of condenser is disconnected or has shorted out	4X	8X	OFF
51	Combination ratio (capacity) is out of range; Total nominal indoor unit capacity is <50% or >130% of the outdoor unit capacity	5X	1X	OFF
53	Communication failure between outdoor unit and indoor unit(s)	5X	3X	OFF
54	Outdoor unit is not wired properly (ex: reversed phase)	5X	4X	OFF
60	Outdoor unit printed circuit board (PCB) EEPROM check sum error	6X	-	OFF
61	Condenser coil thermistor temperature is too high	6X	1X	OFF
62	Outdoor unit inverter compressor PCB heat sink temperature is too high	6X	2X	OFF
65	Heat sink thermistor is disconnected or has shorted out	6X	5X	OFF
67	Outdoor unit brushless direct current (BLDC) fan motor lock error	6X	7X	OFF
73	Outdoor unit PFC overcurrent (peak) error	7X	3X	OFF

# LG MONITORING VIEW (LGMV) DIAGNOSTIC SOFTWARE

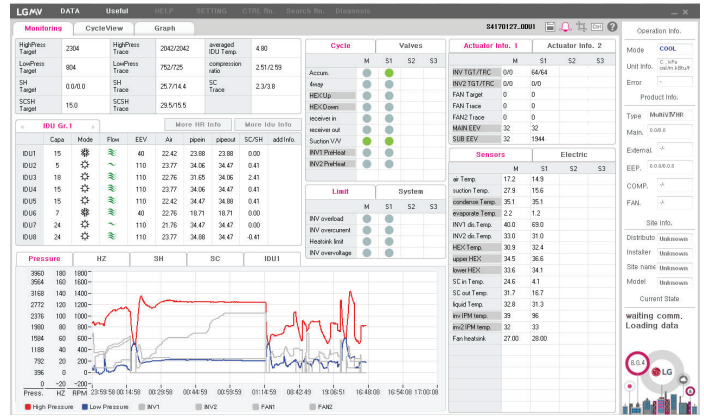
MULTI F  
MULTI F MAX

## LG Monitoring View (LGMV) Diagnostic Software

LG Monitoring View (LGMV) software allows the service technician or commissioning agent to connect a computer USB port to the Multi F / Multi F MAX system's main printed circuit board (PCB) using an accessory cable without the need for a separate interface device.

LGMV is available in different formats, including Mobile LGMV, which is an app for use on wireless devices. Contact your LG Sales Representative for more information, including recommended PC or mobile device configurations.

Figure 131: LGMV Monitoring Screen.



### Note:

- Images on these pages are examples of LGMV screenshots. Actual images will differ depending on the version of the software and the units installed.
- Information displayed also depends on which unit is installed.

### LGMV Display

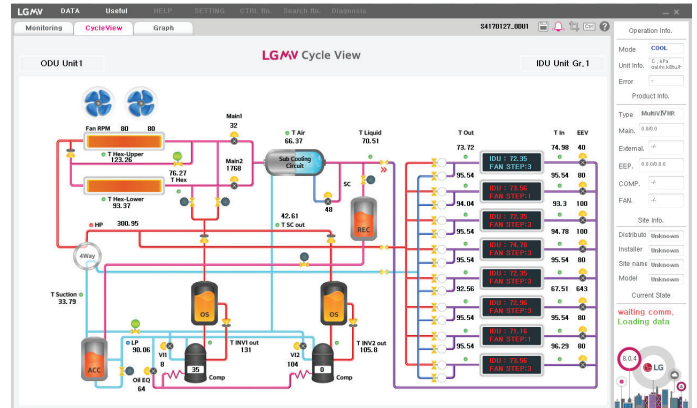
LGMV displays the following real-time data:

- Actual inverter compressor speed
- Target inverter compressor speed
- Actual outdoor fan speed
- Target outdoor unit fan speed
- Actual superheat
- Target superheat
- Actual subcooler circuit superheat
- Target subcooler circuit superheat
- Main EEV position
- Subcooling EEV position
- Inverter compressor current transducer value
- Outdoor air temperature
- Actual high pressure/saturation temperature
- Actual low pressure/saturation temperature
- Suction temperature
- Inverter compressor discharge temperature
- Constant speed compressor discharge temperature
- Front outdoor coil pipe temperature
- Back outdoor coil pipe temperature
- Liquid line pipe temperature
- Subcooler inlet temperature
- Subcooler outlet temperature
- Average indoor unit (IDU) pipe temperature
- Inverter compressor operation indicator light
- Four-way reversing valve operation indicator light
- Pressure graph showing actual low pressure and actual high pressure levels
- Error code display
- Operating mode indicator
- Target high pressure
- Target low pressure
- PCB (printed circuit board) version
- Software version
- Installer name
- Model no. of outdoor units
- Site name
- Total number of connected indoor units
- Communication indicator lights
- Indoor unit capacity
- Indoor unit operating mode
- Indoor unit fan speed
- Indoor unit EEV position
- Indoor unit room temperature
- Indoor unit inlet pipe temperature
- Indoor unit outlet pipe temperature
- Indoor unit error code

Additional screens can be accessed by tabs on the main screen.  
Additional screens include:

1. Cycleview: Graphic of internal components including:
  - Compressors showing actual speeds
  - EEVs
  - Indoor units
  - Liquid injection valves
  - Temperature and pressure sensors
  - Four-way reversing valve
  - Outdoor fans showing status and speeds

Figure 133: LGMV Cycleview Screen.



2. Graph: Full screen graph of actual high and low pressures and high and low pressure limits. A sliding bar allows viewing of previously recorded data.

3. Control IDU: Enables user to turn on IDU's default setpoints of 86°F in heat mode or 64°F in cool mode.

4. Setting: Converts metric values to imperial values.

5. Making Data: Recording of real time data to a separate file created to be stored on the user's computer.

6. Loading Data: Recorded data from a saved ".CSV" file can be loaded to create an LGMV session.

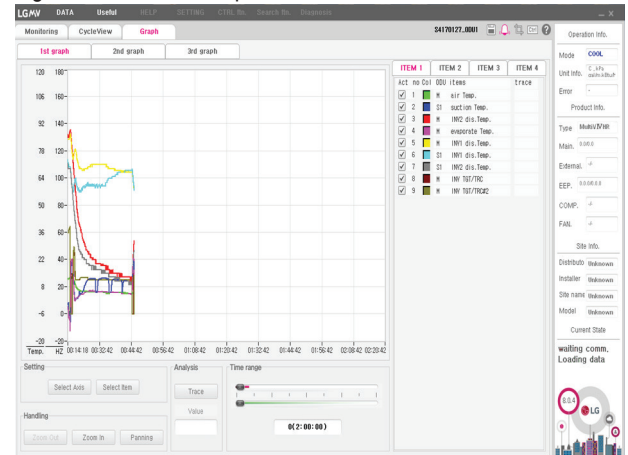
7. Electrical Data: The Electric tab on the main screen is changed to show the following:

- Inverter compressor
  - Amps
  - Volts
  - Power Hz
  - Inverter control board fan Hz
- Constant compressor
  - Current transducer value
  - Phase

**Note:**

- Images on these pages are examples of LGMV screenshots. Actual images will differ depending on the version of the software and the units installed.
- Information displayed also depends on which unit is installed.

Figure 132: LGMV Graph Screen.





# LG SMART INVERTER MONITORING SYSTEM (SIMS)

MULTI F  
MULTI F MAX

## LG SIMS

The LG Smart Inverter Monitoring System (SIMS) WLAN module and the smart phone app together provide monitoring and troubleshooting capability for LG Multi F / Multi F MAX systems. SIMS functions only with LG Duct Free products, and can also be used with Single Zone one-to-one configurations such as the Single Zone Wall Mount systems.

SIMS can display and graph operational data for the air conditioner system including the indoor unit and the outdoor unit. SIMS also displays error codes and a troubleshooting guide. A full copy of the LG SIMS User's Manual is available on the [www.lghvac.com](http://www.lghvac.com) website.

To use SIMS you must be a trained HVAC service technician familiar with LG's Duct Free Systems. You must understand the inverter air conditioning operation cycle, the meaning of the data displayed by SIMS, and how to use the data to troubleshoot the system.

### Note:

- Images on these pages are examples of SIMS screenshots. Actual images will differ depending on the version of the software and the units installed.
- Information displayed also depends on which unit is installed.

### ⚠ WARNING

High voltages capable of causing death are used in this equipment. Outdoor unit power remains connected during this procedure. Take extreme caution not to touch electrical components or connections. Failure to observe this warning can result in death or severe injury.

### Note:

- The Duct Free System air conditioning system must run for at least 15–20 minutes before data collected by SIMS 2.0 is valid for troubleshooting.
- The free SIMS app must be correctly installed on a smart phone before using SIMS.
- Some outdoor units have an LGMV extension cable accessed by removing the side handle cover. If the outdoor unit does not have this extension cable, access the LGMV connector by removing the top cover of the outdoor unit.

### SIMs App Main Info Screen

The main screen is the first screen displayed after wireless connection is established. Tap the Main Info tab to display current readings regarding your indoor and outdoor unit(s). The Operational Info area of the screen will show active functions or modes by illuminating the light to the right of the function.

Additional Help information can be accessed by tapping the Help Menu buttons at the bottom of this screen.

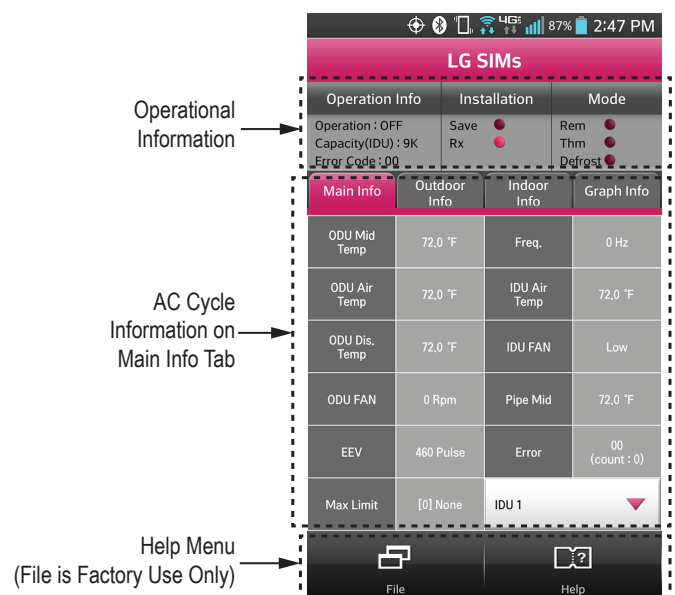
Figure 134: LG SIMS App and WLAN Module.



Figure 135: Example of a SIMS WLAN Module Used with a Typical DFS System.

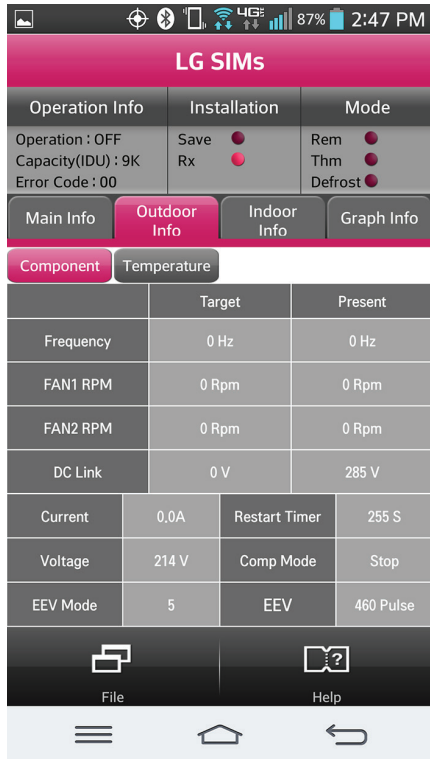


Figure 136: SIMs App Main Info Screen.





## SIMS App Screens



### Outdoor Info / Component Screen

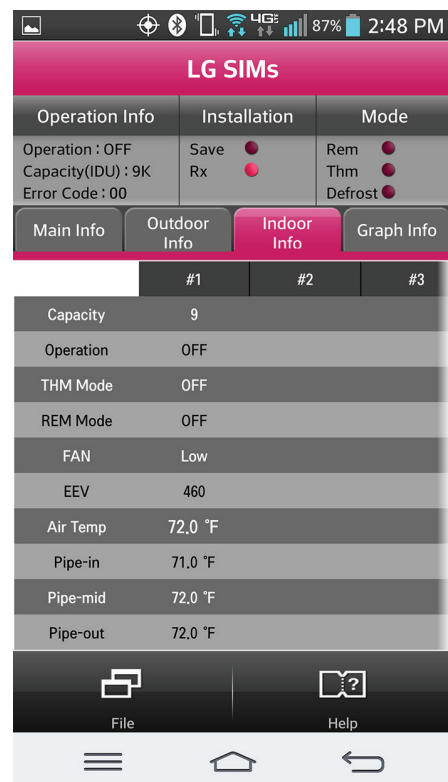
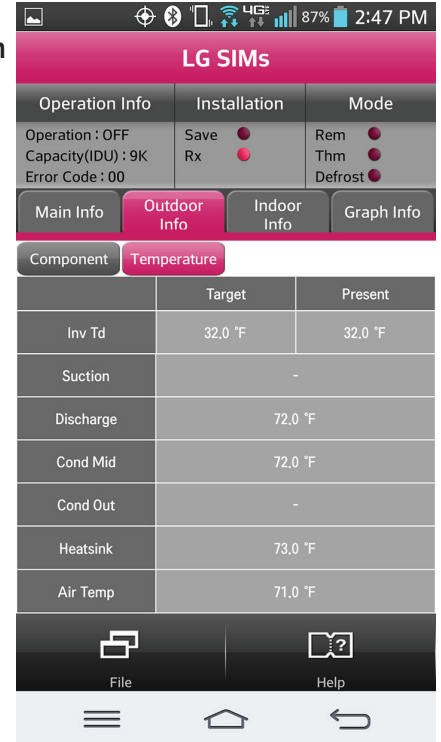
Displays the following information:

- Frequency
- FAN1 RPM
- FAN2 RPM
- DC Link
- Current
- Voltage
- EEV Mode
- Restart Timer
- Comp Mode
- EEV

### Outdoor Info/ Temperature Screen

Displays the following information:

- Inv TD
- Suction
- Discharge
- Cond Mid
- Cond Out
- Heatsink
- Air Temp



### Indoor Info Tab

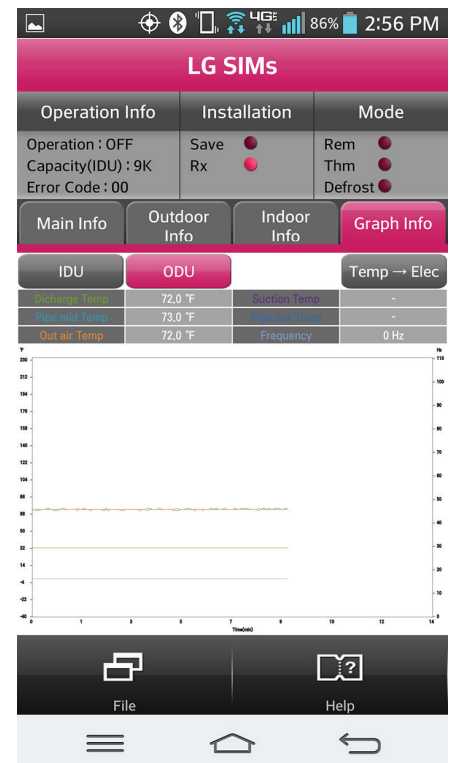
Displays the following information:

- Frequency
- Operation
- THM Mode
- REM Mode
- FAN
- EEV
- Air Temp
- Pipe-in
- Pipe-mid
- Pipe-out

### Graph Info Tab

This tab, has three sub sections:

- IDU - Indoor Unit Temperature graph. Displays IDU information in graph format. Information displayed is for the IDU # selected on the Main screen.
- ODU - Outdoor Unit Temperature and Frequency graph. Displays ODU information in graph format.
- ODU Electric - Outdoor Unit Electric data graph is displayed.



### Note:

- Images on these pages are examples of SIMS screenshots. Actual images will differ depending on the version of the software and the units installed.
- Information displayed also depends on which unit is installed.

Table 44: Maintenance Recommendations.

Component	Maintenance	Occurrence (Minimum)
Indoor Units	Wash filters	On a regular basis / as needed
	Clean coils	Once a year
	Clean / check unit base pan	Once a year
Outdoor Unit(s)	Clean coils	Once or twice a year
Communications Cable and Power Wiring	Verify that all cables and wiring are properly connected	Once or twice a year

**Note:**

*It is also recommended to monitor system operation using LGMV and / or SIMS Software at least once a year.*



# INSTALLATION CHECKLIST

PAGE 1

## Major Component Rough-In

Description	Check
Multi F / Multi F MAX outdoor unit was connected properly per local code and the product installation procedures.	
All literature and bagged accessories have been removed from the fan discharge (ducted and cassette model indoor units).	
All indoor units and branch distribution unit(s) (Multi F MAX only) are installed, properly supported, and located indoors in a non-corrosive environment.	
Duct work installation completed (ducted indoor units only).	

## Piping Material, Components, and Insulation

Description	Check
Multi-zone duct-free split systems: ACR copper piping rated at the system working pressure was used.	
LG Y-branch fitting was used per manufacturer's recommendations.	
All refrigerant pipes and valves were insulated separately. Insulation is positioned up against the walls of the indoor units and branch distribution units (Multi F MAX only). No gaps shown. Insulation was not compressed at clamps and hangers.	

## Brazing Practices

Description	Check
Use medical grade dry nitrogen for purging during brazing (constant 3 psig while brazing).	
15% silver brazing material only.	

## Refrigerant Piping Design and System

Description	Check
You must have in your possession a copy of the "As-Designed" LATS Multi F piping tree diagram. BEFORE ANY FIELD PIPE SIZE OR LENGTH CHANGES ARE MADE, PROPOSED CHANGES MUST BE FORWARDED TO THE DESIGN ENGINEER SO THAT THEY CAN INPUT THE CHANGES INTO LATS and RE-ISSUE A NEW LATS MULTI F PIPING TREE DIAGRAM. Installer must receive change authorization from the design engineer, because any change made requires the review of the entire tree diagram and verification that the change did not impact the size of piping segments in other parts of the system.	
All pipe materials were properly stored, capped, and clean. All burrs were removed after cutting and pipe ends were reamed before brazing.	
During refrigerant pipe installation, for each segment of pipe, a record was made of the pipe length (including expansion loops, offsets, double-back sections), and sizes, as well as the quantity and type of elbows used.	
Expansion loops, coils or other acceptable measures are provided where necessary to absorb temperature-change based pipe movement.	
A torque wrench and backup wrench were used to tighten all flare connections.	
The back side of all flares were lubricated with a small drop of PVE refrigeration oil before tightening flare fittings.	
Ensure all field made flares are 45°. Use factory-supplied flare nuts only.	
Pipe segments and Y-branch fittings are secured to the structure using a combination of fixed and floating clamps, and all wall penetrations were sleeved.	
Pipe insulation was not compressed at any point.	
Y-branch fittings were properly INSTALLED per details provided in the Multi F / Multi F MAX Outdoor Unit Installation Manual.	
Y-branch fittings were properly SUPPORTED per details provided in the Multi F / Multi F MAX Outdoor Unit Installation Manual.	
No oil traps, solenoid valves, sight glasses, filter driers, or any other unauthorized refrigerant specialties were present.	
(Optional) High quality R-410A rated full port ball valves (Schradar between the valve body and the indoor units) used at all indoor units and at will in the refrigerant piping network.	



# INSTALLATION CHECKLIST

PAGE 2

## Condensate Pump / Drain Installation

Description	Check
Condensate piping installed correctly on indoor units. Material used is acceptable under local code. Insulated as necessary to prevent condensation.	
All condensate vertical risers are equal to or less 27-9/16 or 31-1/2 inches from the bottom of the indoor unit (depends on indoor unit).	
Indoor units with condensate pumps were level. Units with gravity drains were level or slightly canted toward the drain connection and are supported properly.	
Pumped condensate drain lines were properly connected (⊘ do not have traps, and connect to the top surface of the main drain line).	
Multi F / Multi F MAX gravity condensate drain line was connected and routed where it properly drains away or, if installed in a mechanical room, was connected and properly routed to a drain terminal.	
All condensate lines were properly insulated to prevent condensation.	

## Power Wire and Communications Cables

Description	Check
Ground wire was installed and properly terminated at the unit.	
Power wiring was connected to a single phase 208-230V source.	
The power supplied was clean with voltage fluctuations within specifications ( $\pm 10\%$ of nameplate).	
Power wiring to the Multi F / Multi F MAX outdoor unit was field supplied, solid or stranded, and installed per all local, state, and NEC requirements.	
For Multi F Systems <ul style="list-style-type: none"> <li>• When the wiring length is up to 130 feet, communication / connection (power) wiring from the outdoor unit to the indoor unit is minimum 14 gauge, four-conductor, stranded, shielded or unshielded. If shielded, must be grounded to chassis at the outdoor unit only.</li> <li>• When the wiring length is GREATER THAN 130 feet, communication / connection (power) wiring from the outdoor unit to the indoor unit is minimum 14 gauge, stranded, shielded or unshielded. If shielded, must be grounded to chassis at the outdoor unit only. Use a two (2) conductor wire for power; use a two (2) conductor wire for communication / ground. Separate the power AT LEAST two (2) inches away from the communication / ground wire.</li> </ul>	
For Multi F MAX Systems <p>All power wiring / communication cable to be minimum 14 AWG from the Multi F MAX outdoor unit to the BD unit stranded, shielded or unshielded (if shielded, it must be grounded to the chassis of the outdoor unit only), and must comply with applicable local and national codes.</p> <ul style="list-style-type: none"> <li>• When the wiring length is up to 130 feet, communication / connection (power) wiring from the BD unit to the indoor unit is minimum 14 gauge, four-conductor, stranded, shielded or unshielded. If shielded, must be grounded to chassis at the outdoor unit only.</li> <li>• When the wiring length is GREATER THAN 130 feet, communication / connection (power) wiring from the BD unit to the indoor unit is minimum 14 gauge, stranded, shielded or unshielded. If shielded, must be grounded to chassis at the outdoor unit only. Use a two (2) conductor wire for power; use a two (2) conductor wire for communication / ground. Separate the power AT LEAST two (2) inches away from the communication / ground wire.</li> </ul>	
Power wiring to the outdoor unit and communication / connection (power) cable from the outdoor unit to the indoor units or branch distribution units (Multi F MAX only) were separated per manufacturer's guidelines. These cannot be run in the same conduit.	
Communications / connection (power) cable were run in the same conduit (outdoor unit to indoor unit or branch distribution unit [Multi F MAX only] as provided in the product installation manual.	
Proper communications cable was used between each indoor unit and its zone controller where applicable. No cables were spliced and no wire nuts are present.	
Communication type RS-485-BUS type.	
Used appropriate crimping tool to attach ring or fork terminals at all power wiring and control cable terminations.	
Only LG-supplied Y-cables were used between grouped indoor units, if applicable.	

# INSTALLATION CHECKLIST

PAGE 3

## Major Component Rough-In

## Piping and Insulation

## Brazing Practices



# INSTALLATION CHECKLIST

PAGE 4

## Installation—Refrigerant Piping

## Installation—Branch Distribution Unit (Multi F MAX Systems Only)

## Installation—Condensate Pump / Drain Installation

## Installation—Power Wire and Communications Cables





# MULTI F REFRIGERANT CHARGE WORKSHEET

LG Multi F outdoor units ship from the factory with a charge of R410A refrigerant. A trim charge will need to be added to take into account additional piping length.

To determine the additional refrigerant that is needed, apply the formula below, and record the results. If the total additional refrigerant charge value is a negative number, then an additional trim charge does not need to be added to the system.

## Multi F Outdoor Unit Factory Charge

Outdoor Unit	Factory Charge lbs. of R410A
LMU180HV	3.97
LMU18CHV	3.96
LMU240HV	3.97
LMU24CHV	3.96
LMU30CHV	6.18
LMU36CHV	6.18
LMU480HV	9.7
LMU540HV	9.7
LMU600HV	12.3

## Multi F Outdoor Unit Additional Refrigerant Charge Formula

$$\begin{aligned}
 \text{Additional charge (lbs.)} = & (\text{Installed Length of Branch [A]} - \text{Chargeless Pipe Length [L]}) \times a \\
 & + (\text{Installed Length of Branch [B]} - \text{Chargeless Pipe Length [L]}) \times a \\
 & + (\text{Installed Length of Branch [C]} - \text{Chargeless Pipe Length [L]}) \times a \\
 & + (\text{Installed Length of Branch [D]} - \text{Chargeless Pipe Length [L]}) \times a \\
 & - \text{CF (Correction Factor)} \times 5.29
 \end{aligned}$$

### Note:

- Number of installed length of branches depends on the specifications of the outdoor unit model.
- CF = Maximum number of connectible indoor units – Total number of connected indoor units.

## Multi F Outdoor Unit Piping Specifications

Multi F Outdoor Unit Model	Min. to Max. Piping Length for One Branch (ft.)	Max. Total System Piping Length (ft.)	Chargeless Pipe Length per Branch (L) (ft.)	Additional Charge Needed (a) (oz./ft.)
LMU180HV	9.8 to 82	164	24.6	0.22
LMU18CHV	9.8 to 82	164	24.6	0.22
LMU240HV	9.8 to 82	230.0	24.6	0.22
LMU24CHV	9.8 to 82	246.1	24.6	0.22
LMU30CHV	9.8 to 82	246.1	24.6	0.22
LMU36CHV	9.8 to 82	246.1	24.6	0.22

## Multi F Refrigerant Charge Calculations

$$\begin{aligned}
 & (\text{_____ [A]} - 24.6) \times 0.22 && (\text{_____}) \\
 + & (\text{_____ [B]} - 24.6) \times 0.22 && + (\text{_____}) \\
 + & (\text{_____ [C]} - 24.6) \times 0.22 && + (\text{_____}) \\
 + & (\text{_____ [D]} - 24.6) \times 0.22 && + (\text{_____}) \\
 - & \text{_____ CF} \times 5.29 && - (\text{_____}) \\
 = & \text{_____ Additional Charge (oz.)}
 \end{aligned}$$



# MULTI F MAX REFRIGERANT CHARGE WORKSHEET

LG Multi F MAX outdoor units ship from the factory with a charge of R410A refrigerant. A trim charge will need to be added to take into account additional piping length.

To determine the additional refrigerant that is needed, apply the formula below, and record the results. If the total additional refrigerant charge value is a negative number, then an additional trim charge does not need to be added to the system.

### Multi F MAX Outdoor Unit Factory Charge

Outdoor Unit	Factory Charge lbs. of R410A
LMU480HV	9.7
LMU540HV	9.7
LMU600HV	12.3

$$\begin{aligned} \text{Additional charge (lbs.)} &= (\text{Total Main Piping Length [A]} - \text{Chargeless Pipe Length of Main Pipe [L]}) \times a \\ &+ (\text{Installed Length of Branch [B1]} - \text{Chargeless Pipe Length [B]}) \times b \\ &+ (\text{Installed Length of Branch [B2]} - \text{Chargeless Pipe Length [B]}) \times b \\ &+ (\text{Installed Length of Branch [B3]} - \text{Chargeless Pipe Length [B]}) \times b \dots \\ &- \text{CF (Correction Factor)} \times 3.53 \end{aligned}$$

### Note:

- Number of installed length of branches depends on system specifications.
- CF = Maximum number of connectible indoor units – Total number of connected indoor units

### Multi F MAX Outdoor Unit Piping Specifications

Outdoor Unit Model	Main Piping Length		Branch Piping Length	
	Chargeless Pipe Length of Main Pipe (L) (ft.)	Additional Charge Needed (a) (oz./ft.)	Chargeless Pipe Length per Branch Pipe (B) (ft.)	Additional Charge Needed (b) (oz./ft.)
LMU480HV	16.4	0.54	16.4	0.22
LMU540HV	16.4	0.54	16.4	0.22
LMU600HV	16.4	0.54	16.4	0.22

### Multi F MAX Refrigerant Charge Calculations

$$\begin{aligned} &(\text{_____ [A]} - 16.4) \times 0.54 && (\text{_____}) \\ + &(\text{_____ [B1]} - 16.4) \times 0.22 && + (\text{_____}) \\ + &(\text{_____ [B2]} - 16.4) \times 0.22 && + (\text{_____}) \\ + &(\text{_____ [B3]} - 16.4) \times 0.22 && + (\text{_____}) \\ + &(\text{_____ [B4]} - 16.4) \times 0.22 && + (\text{_____}) \\ + &(\text{_____ [B5]} - 16.4) \times 0.22 && + (\text{_____}) \\ + &(\text{_____ [B6]} - 16.4) \times 0.22 && + (\text{_____}) \\ + &(\text{_____ [B7]} - 16.4) \times 0.22 && + (\text{_____}) \\ + &(\text{_____ [B8]} - 16.4) \times 0.22 && + (\text{_____}) \\ - &\text{_____ CF} \times 3.53 && - (\text{_____}) \end{aligned}$$

$$= \text{_____ Additional Charge (oz.)}$$

*Inverter*



LG Electronics, U.S.A., Inc.  
Air Conditioning Technologies  
4300 North Point Parkway  
Alpharetta, Georgia 30022  
[www.lghvac.com](http://www.lghvac.com)

IM\_MultiF\_ODU\_02\_21  
Supersedes: IM\_MultiF\_ODU\_09\_20  
IM\_MultiF\_ODU\_06\_20  
IM\_MultiF\_ODU\_04\_20  
IM\_MultiF\_ODU\_03\_17  
IM\_MultiF\_ODU\_11\_16  
IM\_MultiF\_ODU\_4\_16  
IM\_MultiF\_ODU\_11\_15