



SINGLE-ZONE FOUR-WAY CEILING-CASSETTE SYSTEM ENGINEERING MANUAL

Single-Zone Four-Way
Ceiling-Cassette
Heat Pump Systems
3/4 to 3-1/2 Tons



LC098HV (9,000 Btu/h)
LC128HV (12,000 Btu/h)



LC188HV (18,000 Btu/h)



LC249HV (24,000 Btu/h)



LC369HV (36,000 Btu/h)
LC429HV (42,000 Btu/h)

PROPRIETARY DATA NOTICE

This document, as well as all reports, illustrations, data, information, and other materials are the property of LG Electronics U.S.A., Inc., and are disclosed by LG Electronics U.S.A., Inc. only in confidence. This document is for design purposes only.

A summary list of safety precautions is on page 3.

For more technical materials such as submittals, catalogs, installation, best practices, building ventilation, owner's, and service manuals, visit www.lghvac.com.

Proper sizing and installation of equipment is critical to achieve optimal performance. Split system air conditioners and heat pumps (excluding ductless systems) must be matched with appropriate coil components to meet ENERGY STAR® criteria. Ask your contractor for details or visit www.energystar.gov.

(ENERGY STAR and the ENERGY STAR mark are registered trademarks owned by the U.S. Environmental Protection Agency.)





For continual product development, LG Electronics U.S.A., Inc., reserves the right to change specifications without notice.

© LG Electronics U.S.A., Inc.

TABLE OF CONTENTS

Nomenclature.....	4
LG Air Conditioner Technical Solution (LATS)	5-6
Four-Way Ceiling-Cassette Product Data.....	7-47
<i>Mechanical Specifications</i>	8-10
<i>General Data</i>	11-15
<i>Electrical Data</i>	16
<i>Functions, Controls, and Options</i>	17
<i>Outdoor Unit Dimensions</i>	18-20
<i>Indoor Unit Dimensions</i>	21-24
<i>Acoustic Data</i>	25-28
<i>Refrigerant Flow Diagrams</i>	29-33
<i>Wiring Diagrams</i>	34-39
<i>Electrical Connections</i>	40-42
<i>Air Velocity and Temperature Distribution</i>	43-45
<i>Accessories</i>	46-47
Four-Way Ceiling-Cassette Performance Data	48-65
<i>Cooling Capacity</i>	49-54
<i>Heating Capacity</i>	55-57
<i>Maximum Cooling Capacity</i>	58-60
<i>Maximum Heating Capacity</i>	61-63
<i>Equipment Selection Procedure</i>	64-65
Application Guidelines.....	66-78
<i>Placement Considerations</i>	67-74
<i>Installing Outdoor Units Indoors</i>	75-77
<i>Refrigerant Piping Design</i>	78

TABLE OF SYMBOLS

 DANGER	<i>This symbol indicates an imminently hazardous situation which, if not avoided, will result in death or serious injury.</i>
 WARNING	<i>This symbol indicates a potentially hazardous situation which, if not avoided, could result in death or serious injury.</i>
 CAUTION	<i>This symbol indicates a potentially hazardous situation which, if not avoided, may result in minor or moderate injury.</i>
 NOTE	<i>This symbol indicates situations that may result in equipment or property damage accidents only.</i>
Note:	<i>This symbol indicates information related to the current procedure.</i>
	<i>This symbol indicates an action that should not be performed.</i>

UNIT NOMENCLATURE

Indoor Units and Outdoor Units

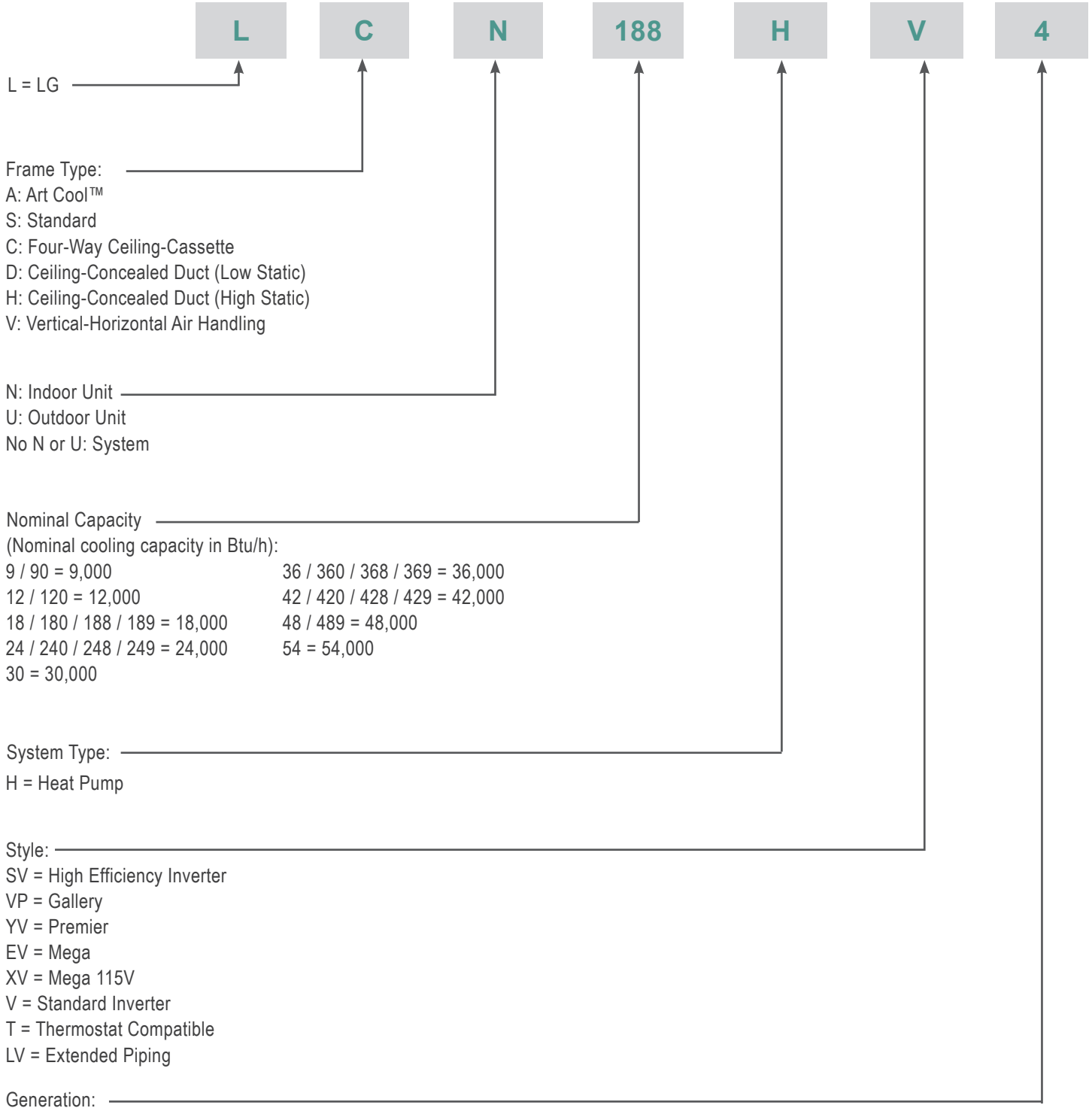

LG AIR CONDITIONER TECHNICAL SOLUTION (LATS)

LG Air Conditioner Technical Solution (LATS) Software

A properly designed and installed refrigerant piping system is critical to the optimal performance of LG air-conditioning systems. To assist engineers, LG offers, free of charge, LG Air Conditioner Technical Solution (LATS) software—a total design solution for LG air conditioning systems. Contact your LG Rep for the best software program for your application.

Note:

To reduce the risk of designing an improper applied system or one that will not operate correctly, LG requires that LATS software be used on all projects.

Formats

LATS is available to LG customers in two user interfaces: LATS HVAC and LATS Revit. Both LATS formats are available through www.myLGHVAC.com, or contact an LG Sales Representative.

LATS HVAC is a Windows®-based application that aids engineers in designing LG Variable Refrigerant Flow (VRF), Multi F / Multi F MAX, Single-Zone, and Energy Recovery Ventilator (ERV) systems.

**Windows® is a registered mark of Microsoft® Corporation.*

LATS Revit integrates the LG LATS program with Revit® software**. It permits engineers to layout and validate Multi V VRF systems directly into Revit drawings.

***Revit® is a registered mark of Autodesk, Inc.*

Features

All LG product design criteria have been loaded into the program, making LATS simple to use: double click or drag and drop the component choices. Build systems in Tree Mode where the refrigerant system can be viewed. Switch to a Schematic diagram to see the electrical and communications wiring.

LATS software permits the user to input region data, indoor and outdoor design temperatures, modify humidity default values, zoning, specify type and size of outdoor units and indoor units, and input air flow and external static pressure (ESP) for ducted indoor units.

The program can also:

- Import building loads from a separate Excel file.
- Present options for outdoor unit auto selection.
- Automatically calculate component capacity based on design conditions for the chosen region.
- Verify if the height differences between the various system components are within system limits.
- Provide the correct size of each refrigerant piping segment and LG Y-Branches and Headers.
- Adjust overall piping system length when elbows are added.
- Check for component piping limitations and flag if any parameters are broken.
- Factor operation and capacity for defrost operation.
- Calculate refrigerant charge, noting any additional trim charge.
- Suggest accessories for indoor units and outdoor units.
- Run system simulation.

Note:

Features depend on which LATS program is being used, and the type of system being designed.

LG AIR CONDITIONER TECHNICAL SOLUTION (LATS)

LATS Generates a Complete Project Report

LATS software also generates a report containing project design parameters, cooling and heating design data, system component performance, and capacity data. The report includes system combination ratio and refrigerant charge calculations; and provides detailed bill of material, including outdoor units, indoor units, control devices, accessories, refrigerant pipe sizes segregated by building, by system, by pipe size, and by pipe segments. LATS can generate an Excel GERP report that can imported into the LG SOPS pricing and ordering system.

Proper Design to Install Procedure

LG encourages a two report design-to-install-procedure. After the design engineer determines building / zone loads and other details, the engineer opens the LATS program and inputs the project's information. When the design is complete, the "Auto Piping" and "System Check" functions must be used to verify piping sizes, limitations, and if any design errors are present. If errors are found, engineers must adjust the design, and run Auto Piping and System Check again. When the design passes the checks, then the engineer prints out a project "Shop Drawing" (LATS Tree Diagram) and provides it to the installing contractor. The contractor must follow the LATS Tree Diagram when building the piping system, but oftentimes the design changes on the building site:

- Architect has changed location and/or purpose of room(s).
- Outdoor unit cannot be placed where originally intended.
- Structural elements prevent routing the piping as planned.
- Air conditioning system conflicts with other building systems (plumbing, gas lines, etc.).

The contractor must mark any deviation from the design on the Shop Drawing, including as-built straight lines and elbows. This "Mark Up" drawing must be returned to the design engineer or Rep, who must input contractor changes into the LATS file. (Copy the original LATS software file, save and rename as a separate file, and modify all piping lengths by double-clicking on each length and editing information.) Like the shop drawing, the Auto Piping and System Check must also be run on this new "As Built" drawing. The design engineer or Rep must then provide the final As Built file to the contractor. The Mark Up version must be compared to the As Built version for:

- Differences in pipe diameter(s). If incorrect diameters have been installed, the piping must be changed out. If pipe diameters have changed, check to see if Y-Branches will also need to be changed.
- Changes to outdoor unit and indoor unit capacities. Capacities changes will impact line length changes.
- Additional refrigerant charge quantity ("Trim Charge"). Trim charge will change if piping lengths and diameters change. The As Built version must reflect installed piping lengths to ensure correct trim charge.

All documents submitted by the contractor, as well as the Shop Drawing and the As Built Drawing files must be provided for commissioning purposes. Model and serial numbers for all system components must also be submitted. If the steps previously detailed are not followed, and all documents are not provided to the commissioning agent, the project runs the risk of not being commissioned and voiding any limited warranty LG offers on the equipment.

Note:

Contact your LG representative for the best software program for your application.

Figure 1: Example of a LATS Tree Diagram.

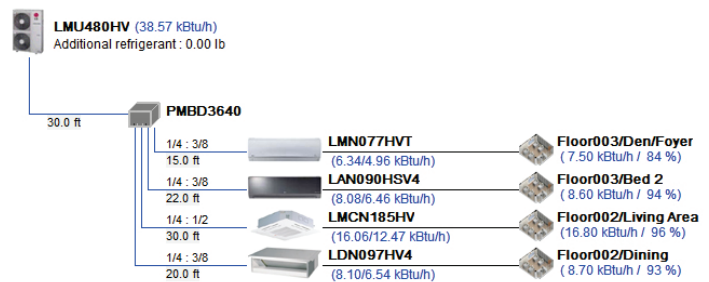

PRODUCT DATA

Mechanical Specifications on page 8

General Data on page 11

Electrical Data on page 16

Functions, Controls, and Options on page 17

Outdoor Unit Dimensions on page 18

Indoor Unit Dimensions on page 21

Acoustic Data on page 25

Refrigerant Flow Diagrams on page 29

Wiring Diagrams on page 34

Electrical Connections on page 40

Air Velocity and Temperature Distribution on page 43

Accessories on page 46

MECHANICAL SPECIFICATIONS

General

System

LG single zone four-way ceiling cassette system comprises of a single frame outdoor unit connected to a single indoor unit with a single refrigerant circuit. An LG single zone four-way ceiling cassette is a system that can operate in either cooling or heating mode. The system is capable of changing mode within a maximum time of three (3) minutes to ensure indoor temperature can be properly maintained. LG components are manufactured in a facility registered to ISO 9001 and ISO 14001, which is a set of standards applying to environmental protection set by the International organization for Standardization (ISO). The system components comply with CSA Standard for Safety and bear the CSA label. Wiring in these units are in accordance with the national Electrical Code (NEC). LG single zone four-way ceiling cassette systems have published performance ratings certified by AHRI (Air-Conditioning, Heating, and Refrigeration Institute) and are listed in the AHRI Standard 210 / 240 certified product directory.

9,000 and 12,000 Btu/h Ceiling Cassette Temperature Operating Ranges

- Operating ranges for outdoor units of 0°F to +118°F (DB) for cooling (Cooling range can be extended from 0°F down to -4°F using the Low Ambient Wind Baffle Kit [sold separately]); -4°F to +64°F (WB) for heating.
- Operating ranges for indoor units of 57°F to 77°F (WB) for cooling; 59°F to 81°F (DB) for heating.
- Indoor unit temperature setting range of 65°F to 86°F (DB) for cooling; 61°F to 86°F (WB) for heating.

18,000, 24,000, 36,000, and 42,000 Btu/h Ceiling Cassette Temperature Operating Ranges

- Operating ranges for outdoor units of 5°F to +118°F (DB) for cooling (Cooling range can be extended from 5°F down to -4°F using the Low Ambient Wind Baffle Kit [sold separately]); -4°F to +64°F (WB) for heating.
- Operating ranges for indoor units of 57°F to 77°F (WB) for cooling; 59°F to 81°F (DB) for heating.
- Indoor unit temperature setting range of 65°F to 86°F (DB) for cooling; 61°F to 86°F (WB) for heating.

Refrigerant System

The system is designed for use with R410A refrigerant, and consists of a single refrigeration circuit. The refrigeration circuit is pressure-tested at the factory and shipped with a holding charge of helium gas. The outdoor unit is provided with factory installed components, including a refrigerant strainer, accumulator, four-way reversing valve, electronic expansion valve (EEV), high and low side charging ports, service valves, and interconnecting piping. All refrigerant lines from the outdoor unit to the indoor unit are field-installed and must be insulated separately.

Electrical

The system was designed to operate using 208–230/60/1 power with voltage variances of $\pm 10\%$ and includes overcurrent protection. The indoor unit is powered through the outdoor unit.

Controls

Indoor and outdoor units are factory wired with necessary electrical control components, printed circuit boards, thermistors, sensors, terminal blocks, and lugs for power wiring. Factory installed microprocessor controls in the outdoor unit and indoor unit perform functions to efficiently operate the single zone system, communicating via a 14 AWG four-conductor, stranded, shielded or unshielded (if shielded, must be grounded to the chassis at the outdoor unit only) power/transmission cable (and must comply with applicable local and national codes). Microprocessor-based algorithms provide component protection, soft-start capability, refrigeration system pressure, temperature, defrost, and ambient control. System can be operated through a handheld wireless controller supplied with the four-way ceiling cassette indoor unit.

Figure 2: Four-Way Ceiling Cassette System (LC098HV and LC128HV Models).



Outdoor Unit

Sound Levels

The outdoor units have sound levels not exceeding 54 dB(A) tested in an anechoic chamber under ISO Standard 3745.

Casing / Frame

The outdoor condensing unit case is constructed from pre-coated metal (PCM) that has been tested in accordance with ASTM B-117 salt spray procedure for a minimum of 1,000 hours. Case has a removable panel to allow access to major internal components, and legs to secure the unit during installation.

Compressors

The 9,000 ~ 24,000 Btu/h outdoor units are equipped with one hermetically sealed, digitally controlled, inverter-driven twin rotary compressor to modulate capacity (modulation in 1 Hz increments). The 36,000 and 42,000 Btu/h outdoor units are equipped with one hermetically sealed, digitally controlled, inverter-driven scroll compressor to modulate capacity (modulation in 1 Hz increments). Teflon coated bearings, overcurrent protection and vibration isolation are integrated with the compressor.

MECHANICAL SPECIFICATIONS

Frequency ranges for the 9,000 ~ 24,000 Btu/h outdoor units are:

9k Btu/h = 20 Hz to 100 Hz Cooling / Heating

12k Btu/h = 20 Hz to 100 Hz Cooling / Heating

18k Btu/h = 15 to 80 Hz Cooling; 15 to 100 Hz Heating

24k Btu/h = 15 to 80 Hz Cooling; 15 to 100 Hz Heating

Frequency ranges for the 36,000 and 42,000 Btu/h outdoor units are:

36k Btu/h = 10 to 120 Hz Cooling; 10 to 135 Hz Heating

42k Btu/h = 10 to 120 Hz Cooling; 10 to 135 Hz Heating

Coil

Heat pump outdoor unit coils are made of nonferrous louvered aluminum fins protected with an integral coil guard. The coil for each outdoor unit has a minimum of 14 fins per inch (FPI); heat exchanger has two rows. The coil fins have a factory applied corrosion resistant GoldFin™ material with hydrophilic coating tested in accordance with ASTM B-117 salt spray test procedure for a minimum of 1,000 hours. Coils are factory tested to a pressure of 551 psig.

Fans and Motors

The 9,000 Btu/h (LUU090HV), 12,000 Btu/h (LUU120HV), 18,000 Btu/h (LUU180HV), and 24,000 Btu/h (LUU240HV) outdoor units include one direct drive, variable speed axial / propeller type fan with a horizontal air discharge; the 36,000 Btu/h (LUU360HV) and 42,000 Btu/h (LUU420HV) include two fans. Fan blades are made of Acrylonitrile Butadiene Styrene (ABS) material, and have a Brushless Digitally Controlled (BLDC) fan motor. The fan motor has inherent protection, permanently lubricated bearings, and variable speed with a maximum speed up to 850 rpm (9,000 and 12,000 Btu/h), up to 760 rpm (18,000 and 24,000 Btu/h), or up to 750 rpm (36,000 and 42,000 Btu/h). Raised guards are provided to limit contact with moving parts.

Indoor Unit

Sound Levels

The indoor units have sound ratings no higher than 47 dB(A) as tested per ISO Standard 3745.

Casing / Frame

The indoor unit case is constructed coated metal designed to mount recessed recess in the ceiling, and has a surface-mounted concentric panel on the bottom of the unit. Cold surfaces are covered with a coated polystyrene insulating material. The case is provided with metal ears designed to support the unit weight on four corners. Ears have pre-punched holes designed to accept field-supplied all-thread rod hangers.

Unit has four supply air outlets and one return air inlet. The supply air outlet has four-directional slot diffusers, each equipped with an independent oscillating motorized guide vane to change airflow direction. A guide vane algorithm sequentially changes the predominant discharge airflow direction in counterclockwise pattern,

or can be used to lock each guide vane independently in a field-adjusted fixed position. The four vanes can be individually adjusted from the wired remote controller to customize the airflow pattern for the conditioned space. A setting in the cooling and heating modes can cycle the vanes up and down for uniform / random air distribution.

Panels are sold as separate required accessories. The four-way panel is white acrylonitrile butadiene styrene (ABS) polymeric resin with a tapered trim edge.

Coil

Indoor unit coils are factory built and are comprised of aluminum fins mechanically bonded to grooved-design copper tubes with slit coil fins.

Each indoor unit has two (2) rows of coils and: eight (8) columns, 18 fins per inch (9,000 and 12,000 Btu/h); ten (10) columns, 18 fins per inch (18,000 Btu/h); eight (8) columns, 19 fins per inch (24,000 Btu/h); 12 columns, 21 fins per inch (36,000 Btu/h); 18 columns, 24 fins per inch (42,000 Btu/h) that are pressure tested to 551 psig at the factory. Each unit is provided with a factory installed condensate drain pan below the coil.

Fans and Motors

All of the indoor units have a single, direct-drive, turbo fan manufactured of high-strength ABS HT-700 polymeric resin; the fans are statically and dynamically balanced. The fan motor is brushless digitally controlled (BLDC) with permanently lubricated and sealed ball bearings. The fan motor includes thermal, overcurrent and low RPM protection. The fan / motor assembly is mounted on vibration-attenuating rubber grommets.

Fan speed is controlled using a microprocessor-based, direct-digital control algorithm that provides pre-programmed, field-selectable fixed or auto fan speeds in the Heating and Cooling modes. The fan speeds can be field adjusted between low, medium, and high. Auto setting adjusts the fan speed based on the difference between the controller set-point and space temperature.

Microprocessor Controls

A temperature thermistor is factory-mounted in the return air stream. All unit operation parameters, excluding the unit operating schedule, are stored in non-volatile memory resident on the unit

Figure 3: Four-Way Ceiling Cassette System (LC369HV, LC429HV Models).



MECHANICAL SPECIFICATIONS

microprocessor. Operating schedules are stored in select models of the optional, wall-mounted, local, or central controller.

For heat pump systems, heated or cooled air delivery is dependent upon outdoor unit operating mode. In Heating mode, the microprocessor control will activate indoor unit operation when the indoor room temperature falls below setpoint temperature. At which point, a signal is sent to the outdoor unit to begin the heating cycle. The indoor unit fan operation is delayed until coil pipe temperature reaches 76°F. Significant airflow is generated when pipe temperature reaches 80°F. The unit is equipped with an infrared receiver designed to communicate with an LG wireless remote controller. In lieu of wireless remote or factory return air thermistor, screw terminals on the microprocessor circuit board accommodate various models of wall-mounted local controllers and/or a wall-mounted remote temperature sensor. The unit microprocessor is capable of accepting space temperature readings concurrently or individually from either:

1. Wall-mounted wired controller(s)
2. Factory mounted return air thermistor or the optional wall mounted wired remote temperature sensor.

The indoor units are Wi-Fi compatible with the addition of an LG Wi-Fi module accessory, and can be controlled by LG's ThinQ™ app on a smart device. A field-supplied Wi-Fi network and smart device are required. The ThinQ app is free, and is available for Android™ and iOS. (Android is a trademark of Google LLC.)

Architectural Panel / Air Filter — TP-B Frame for 3'x3' 24,000 Btu/h Indoor Units; TM-A Frame for 3'x3' 36,000 Btu/h and 42,000 Btu/h Indoor Units

The unit case allows access to hanger rods and the inspection of piping through corner access panels on the architectural panel. The optional auto-elevating panel kit is designed to provide motorized ascent/descent of the return air panel/pre-filter assembly a distance of up to 12 feet allowing easy access to remove and clean the filter.

The kit consists of two lifting mechanisms comprised of an electric motor driven winch with four (4) braided steel lifting cables. The winch kit is mounted behind the panel and is not visible during normal unit operation. The auto-elevating return air panel appearance and finish matches that of the architectural panel on similar indoor unit models equipped with the standard hinged filter panels. The auto-elevating panel control algorithm accepts up, down, and stop control commands from either a wall-mounted or the lift remote controller. The algorithm does not permit the lowering of the panel while the indoor unit fan is operating. The pair of winch controllers work in unison to keep the return air panel level during lift and descent operations and will automatically stop the descent of the return air panel/filter if contact is made with any obstacle.

Airflow Guide Vanes — TP-B Frame for 3'x3' 24,000 Btu/h Indoor Units; TM-A Frame for 3'x3' 36,000 Btu/h and 42,000 Btu/h Indoor Units

The architectural panel has four-directional slot diffusers each equipped with independent dual-vane oscillating motorized guide vanes designed to change the angle airflow is discharged. Discharge range of motion is 10° to 85° in an up/down direction. A control algorithm provides the capability of locking each guide vane independently in a field adjusted fixed position. Guide vanes provide airflow in all directions. The ends of each vane are tapered to provide airflow to the space in the direction of the four corners of the architectural panel.

Filters

Return air is filtered with a factory-supplied, removable, washable MERV 6 rated prefilter accessible from the bottom of the unit. For 2' x 2' cassettes the removable washable filter size is 14" x 14" x 1". For 3' x 3' cassettes the removable washable filter size is 20.5" x 20.5" x 1". An optional Premium Panel accessory with the PTAHMPO Air Purification Kit is also available for the 3' x 3' cassettes.

Ventilation Air — TR Frame for 2'x2' 9,000 Btu/h and 12,000 Btu/h Indoor Units; TQ Frame for 2'x2' 18,000 Btu/h Indoor Units

The case has a factory designated cutout for the connection of a field-supplied outside air duct. An optional flange kit is available from LG.

Ventilation Air — TP-B Frame for 3'x3' 24,000 Btu/h Indoor Units; TM-A Frame for 3'x3' 36,000 Btu/h and 42,000 Btu/h Indoor Units

The case has a factory designated cutout for the connection of a field-supplied outside air duct. LG offers two flange kits.

Supply Air Branch Duct Connections

Factory designated cutouts are marked on the unit case. Branch ducts provide the designer with the ability to duct up to 1/2 the unit airflow capacity to adjacent spaces. The adjacent space must be in the room where the ceiling cassette is installed. It cannot be branched to another room.

Condensate Lift / Pump

The indoor unit is provided with a factory installed and wired condensate lift/pump capable of providing a maximum 27-9/16 inch (9,000, 12,000, and 18,000 Btu/h) or 31-1/2 inch (24,000, 36,000, and 42,000 Btu/h) lift from the bottom surface of the unit. Drain pump has a safety switch to shut off the indoor unit if the condensate rises too high in the drain pan.

Condensate Drain Pan













The condensate drain pan is constructed of EPS (expandable polystyrene resin).

GENERAL DATA

Pairing Table

The following table shows the available outdoor and indoor unit, along with the factory provided controller.

Table 1: Four-Way Ceiling Cassette System Pairing Table

Outdoor Unit Model	Indoor Unit Model	Controller
LUU090HV LUU120HV 	LCN098HV4 LCN128HV4 	AKB73757604 (Also referenced by Model No. PQWRHQ0FDB) 
LUU180HV 	LCN188HV4 	AKB73757604 (Also referenced by Model No. PQWRHQ0FDB) 
LUU240HV 	LCN249HV 	AKB75735404 
LUU360HV LUU420HV 	LCN369HV LCN429HV 	AKB75735404 

Product Data

GENERAL DATA

Table 2: Four-Way 2 x 2 Ceiling Cassette System General Data.

System (Model) (Indoor Unit / Outdoor Unit)	LC098HV (LCN098HV4 / LUU090HV)	LC128HV (LCN128HV4 / LUU120HV)	LC188HV (LCN188HV4 / LUU180HV)
Ceiling Grille Model Number (Sold Separately)	PT-QAGW0	PT-QAGW0	PT-QAGW0
Cooling Capacity (Min/Rated/Max) (Btu/h)	3,600 ~ 9,000 ~ 9,900	3,400 ~ 11,100 ~ 12,400	7,700 ~ 18,000 ~ 24,800
Cooling Power Input ¹ (Min/Rated/Max) (kW)	0.19 ~ 0.66 ~ 0.83	0.25 ~ 0.88 ~ 1.1	0.54 ~ 1.44 ~ 2.60
EER2 (@95°F)	13.65	12.6	12.5
SEER2	20.2	19.4	20.5
Heating Capacity (Min/Rated/Max) (Btu/h)	4,400 ~ 11,000 ~ 12,100	2,800 ~ 14,000 ~ 15,500	6,500 ~ 18,500 ~ 23,400
Heating Power Input ¹ (Min/Rated/Max) (kW)	0.15 ~ 0.83 ~ 1.05	0.22 ~ 1.19 ~ 1.5	0.50 ~ 1.95 ~ 2.60
COP (@47°F)	3.88	3.44	2.78
HSPF2	10.55	10.35	9.70
<i>Rated Low Heating Capacity (Btu/h)</i>			
Outdoor 17°F (WB)/Indoor 70°F (DB)	7,000	9,100	12,700
Low COP (@17°F)	2.92	2.7	2.45
<i>Maximum Heating Capacity (Btu/h)</i>			
Outdoor 17°F (DB)/Indoor 70°F (DB)	11,000	11,900	17,000
Outdoor 5°F (DB)/Indoor 70°F (DB)	10,100	10,700	16,200
Outdoor -4°F (DB)/Indoor 70°F (DB)	9,040	9,280	15,250
ENERGY STAR 6.1 / Cold Climate	Yes / Yes	Yes / Yes	Yes / Yes
Power Supply V, Ø, Hz ²	208-230 / 1 / 60		
Power Wiring / Communications Cable (No. x AWG) ³	4 x 14	4 x 14	4 x 14
<i>Outdoor Unit Operating Range</i>			
Cooling (°F DB)	0 to +118 ⁶		5 to +118 ⁶
Heating (°F WB)	-4 to +64		
<i>Indoor Unit Operating Range</i>			
Cooling (°F WB)	57 to 77		
Heating (°F DB)	59 to 81		
<i>Indoor Temperature Setting Range</i>			
Cooling (°F DB)	65 to 86		
Heating (°F DB)	61 to 86		
<i>Unit Data</i>			
Refrigerant Type ³ / Refrigerant Control	R410A / EEV		
IDU Sound Pressure Level ±1 dB(A) (H/M/L) ⁴	36 / 33 / 30	38 / 35 / 32	43 / 41 / 38
ODU Sound Pressure Level ±1 dB(A) (Max.) (Cool/Heat) ⁴	47 / 51	49 / 52	48 / 52
ODU External Static Pressure	0.1	0.1	0.1
IDU Dimensions (W x H x D) (in.)	22-7/16 x 8-7/64 x 22-7/16		22-7/16 x 10-5/64 x 22-7/16
ODU Dimensions (W x H x D) (in.)	30-5/16 x 21-15/32 x 11-11/32		37-13/32 x 32-27/32 x 13.0
IDU Net / Shipping Weight (lbs.)	31 / 37	31 / 37	32 / 40
ODU Net / Shipping Weight (lbs.)	71 / 76	71 / 76	130.1 / 147.7
Grille Net / Shipping Weight (lbs.)	7 / 9	7 / 9	7 / 9

EEV: Electronic Expansion Valve, IDU: Indoor Unit, ODU: Outdoor Unit. Unit comes with a dry helium charge. This data is rated 0 ft above sea level, with 24.6 ft of refrigerant line per indoor unit and a 0 ft level difference between outdoor and indoor units.

Cooling capacity rating obtained with air entering the indoor coil at 80°F dry bulb (DB) and 67°F wet bulb (WB); and outdoor ambient conditions of 95°F dry bulb (DB) and 75°F wet bulb (WB).

Heating capacity rating obtained with air entering the indoor unit at 70°F dry bulb (DB) and 60°F wet bulb (WB); and outdoor ambient conditions of 47°F dry bulb (DB) and 43°F wet bulb (WB).

¹Power Input is rated at high speed.

²All power wiring/communication cables from ODU to IDU are field supplied and are to be minimum 14

AWG, 4-conductor, stranded, shielded or unshielded (if shielded, must be grounded to chassis at ODU only), and must comply with applicable local and national codes.

³Take appropriate actions at the end of HVAC equipment life to recover, recycle, reclaim or destroy R410A refrigerant according to applicable regulations (40 CFR Part 82, Subpart F) under section 608 of CAA.

⁴Sound pressure levels are tested in an anechoic chamber under ISO Standard 3745.

⁵Piping lengths are equivalent.

⁶Cooling range can be extended from 0°F or 5°F down to -4°F using the Low Ambient Wind Baffle Kit (sold separately).

GENERAL DATA

Table 3: Four-Way 2 x 2 Ceiling Cassette System General Data (continued).

Compressor (Type x Qty.)	Twin Rotary x 1	Twin Rotary x 1	Twin Rotary x 1
Dehumidification Rate (pts./hr.)	1.6	2.47	3.3
Heat Exchanger			
Material and Fin Coating	Copper Tube / Aluminum Fin and Gold Fin™ Coated / Hydrophilic		
Rows / Columns / Fin per inch x Qty.	(2 x 24 x 14) x 1	(2 x 24 x 14) x 1	(2 x 38 x 14) x 1
Fan			
Indoor Unit Type x Qty.	Turbo x 1		
Outdoor Unit Type x Qty.	Axial x 1		
Outdoor Unit Motor Output (W) x Qty.	43 x 1	43 x 1	124 x 1
Outdoor Unit Motor / Drive	Brushless Digitally Controlled / Direct		
Airflow Rate			
Indoor Unit (H / M / L [CFM])	300 / 265 / 230	335 / 283 / 247	459 / 424 / 388
Outdoor Unit (Maximum) (CFM)	988	988	2,048
Piping			
Liquid (in.)	Connection / Pipe Size	1/4 / 1/4	1/4 / 3/8
Vapor (in.)	Connection / Pipe Size	3/8 / 3/8	1/2 / 5/8
Indoor Unit Condensate Drain O.D. / I.D. (in.)	1-1/4 / 1		1-1/4 / 1
Refrigerant Pre-Charge (oz.)	38.8		70.56
Additional Refrigerant Charge (oz./ft.)	0.22		0.43
Pipe Length (Minimum / Maximum) (ft.)	16.4 / 66		16.4 / 164
Piping Length ⁵ (no additional refrigerant, ft.)	24.6		24.6
Maximum Elevation Difference (ft.)	49		98.4

EEV: Electronic Expansion Valve, IDU: Indoor Unit, ODU: Outdoor Unit. Unit comes with a dry helium charge. This data is rated 0 ft above sea level, with 24.6 ft of refrigerant line per indoor unit and a 0 ft level difference between outdoor and indoor units.

Cooling capacity rating obtained with air entering the indoor coil at 80°F dry bulb (DB) and 67°F wet bulb (WB); and outdoor ambient conditions of 95°F dry bulb (DB) and 75°F wet bulb (WB). Heating capacity rating obtained with air entering the indoor unit at 70°F dry bulb (DB) and 60°F wet bulb (WB); and outdoor ambient conditions of 47°F dry bulb (DB) and 43°F wet bulb (WB).

¹Power Input is rated at high speed.

²All power wiring/communication cables from ODU to IDU are field supplied and are to be minimum 14

AWG, 4-conductor, stranded, shielded or unshielded (if shielded, must be grounded to chassis at ODU only), and must comply with applicable local and national codes.

³Take appropriate actions at the end of HVAC equipment life to recover, recycle, reclaim or destroy R410A refrigerant according to applicable regulations (40 CFR Part 82, Subpart F) under section 608 of CAA.

⁴Sound pressure levels are tested in an anechoic chamber under ISO Standard 3745.

⁵Piping lengths are equivalent.

⁶Cooling range can be extended from 0°F or 5°F down to -4°F using the Low Ambient Wind Baffle Kit (sold separately).

GENERAL DATA

Table 4: Four-Way 3 x 3 Ceiling Cassette System General Data.

System (Model) (Indoor Unit / Outdoor Unit)	LC249HV (LCN249HV / LUU240HV)	LC369HV (LCN369HV / LUU360HV)	LC429HV (LCN429HV / LUU420HV)
Ceiling Grille Model Number (Sold Separately)	PT-AAGW0	PT-AAGW0	PT-AAGW0
Cooling Capacity (Min/Rated/Max) (Btu/h)	9,600~23,000~28,000	14,400~36,000~42,000	16,800~42,000~48,700
Cooling Power Input ¹ (Min/Rated/Max) (kW)	0.48 ~ 1.96 ~ 3.04	0.72 ~ 2.88 ~ 3.90	1.16 ~ 4.01 ~ 5.5
EER2 (@95°F)	11.70	12.50	10.45
SEER2	20.0	21.0	19.3
Heating Capacity (Min/Rated/Max) (Btu/h)	10,800~27,000~30,000	16,000~40,000~42,200	18,800~47,000~49,800
Heating Power Input ¹ (Min/Rated/Max) (kW)	0.58 ~ 2.25 ~ 3.20	0.80 ~ 3.26 ~ 4.20	1.17 ~ 3.63 ~ 4.93
COP (@47°F)	3.51	3.60	3.79
HSPF2	10.2	10.0	10.05
<i>Rated Low Heating Capacity (Btu/h)</i>			
Outdoor 17°F (WB)/Indoor 70°F (DB)	17,400	24,000	28,000
Low COP (@17°F)	2.68	2.69	2.95
<i>Maximum Heating Capacity (Btu/h)</i>			
Outdoor 17°F (DB)/Indoor 70°F (DB)	26,000	38,000	41,500
Outdoor 5°F (DB)/Indoor 70°F (DB)	21,200	35,000	39,000
Low COP (OD 5°F)	2.07	2.10	1.96
Outdoor -4°F (DB)/Indoor 70°F (DB)	20,760	31,450	38,230
ENERGY STAR 6.1 / Cold Climate	Yes / Yes	Yes / Yes	No / Yes
Power Supply V, Ø, Hz ²	208-230 / 1 / 60		
Power Wiring / Comm. Cable (No. x AWG) ²	4 x 14	4 x 14	4 x 14
<i>Outdoor Unit Operating Range</i>			
Cooling (°F DB)	5 to +118 ⁶		
Heating (°F WB)	-4 to +64		
<i>Indoor Unit Operating Range</i>			
Cooling (°F WB)	57 to 77		
Heating (°F DB)	59 to 81		
<i>Indoor Temperature Setting Range</i>			
Cooling (°F DB)	65 to 86		
Heating (°F DB)	61 to 86		
<i>Unit Data</i>			
Refrigerant Type ³ / Refrigerant Control	R410A / EEV		
IDU Sound Pressure Level ±1 dB(A) (Mx/H/M/L/SL) ⁴	48 / 40 / 37 / 35 / 32	55 / 44 / 42 / 41 / 40	56 / 46 / 43 / 41 / 39
ODU Sound Pressure Level ±1 dB(A) (Max.) (Cool/Heat) ⁴	48 / 52	52 / 54	52 / 54
ODU External Static Pressure	0.1	0.1	0.1
IDU Dimensions (W x H x D) (in.)	33-1/16 x 8-1/32 x 33-1/16		
ODU Dimensions (W x H x D) (in.)	37-13/32 x 32-27/32 x 13.0	37-13/32 x 54-11/32 x 13.0	37-13/32 x 54-11/32 x 13.0
Indoor Unit Net / Shipping Weight (lbs.)	45.9 / 54.9	56.4 / 67.7	60.2 / 70.5
Outdoor Unit Net / Shipping Weight (lbs.)	130.1 / 147.7	193.1 / 217.4	193.1 / 217.4
Grille Net / Shipping Weight (lbs.)	15.6 / 20.5	15.6 / 20.5	15.6 / 20.5

EEV: Electronic Expansion Valve, IDU: Indoor Unit, ODU: Outdoor Unit. Unit comes with a dry helium charge. This data is rated 0 ft above sea level, with 24.6 ft of refrigerant line per indoor unit and a 0 ft level difference between outdoor and indoor units.

Cooling capacity rating obtained with air entering the indoor coil at 80°F dry bulb (DB) and 67°F wet bulb (WB); and outdoor ambient conditions of 95°F dry bulb (DB) and 75°F wet bulb (WB). Heating capacity rating obtained with air entering the indoor unit at 70°F dry bulb (DB) and 60°F wet bulb (WB); and outdoor ambient conditions of 47°F dry bulb (DB) and 43°F wet bulb (WB).

¹Power Input is rated at high speed.

²All power wiring/communication cables from ODU to IDU are field supplied and are to be minimum 14

AWG, 4-conductor, stranded, shielded or unshielded (if shielded, must be grounded to chassis at ODU only), and must comply with applicable local and national codes.

³Take appropriate actions at the end of HVAC equipment life to recover, recycle, reclaim or destroy R410A refrigerant according to applicable regulations (40 CFR Part 82, Subpart F) under section 608 of CAA.

⁴Sound pressure levels are tested in an anechoic chamber under ISO Standard 3745.

⁵Piping lengths are equivalent.

⁶Cooling range can be extended from 5°F down to -4°F using the Low Ambient Wind Baffle Kit (sold separately).

GENERAL DATA

Table 5: Four-Way 3 x 3 Ceiling Cassette System General Data (continued).

Compressor (Type x Qty.)	Twin Rotary x 1	Scroll x 1	Scroll x 1
Dehumidification Rate (pts./hr.)	3.8	7.1	7.27
Heat Exchanger			
Material and Fin Coating	Copper Tube / Aluminum Fin and Gold Fin™ Coated / Hydrophilic		
Rows / Columns / Fin per inch x Qty.	(2 x 38 x 14) x 1	(2 x 32 x 14) x 1	(2 x 32 x 14) x 1
Fan			
Indoor Unit Type x Qty.	Turbo x 1	Turbo x 1	
Outdoor Unit Type x Qty.	Axial x 1	Axial x 2	
Outdoor Unit Motor Output (W) x Qty.	124 x 1	124 x 2	124 x 2
Motor / Drive	Brushless Digitally Controlled / Direct		
Airflow Rate			
Indoor Unit (Max / H / M / L [CFM])	794 / 671 / 600 / 530	1,200 / 971 / 883 / 794	1,483 / 1,130 / 953 / 812
Outdoor Unit (Maximum) (CFM)	2,048	2 x 1,942	2 x 1,942
Piping			
Liquid (in.)	Connection / Pipe Size	3/8 / 3/8	3/8 / 3/8
Vapor (in.)	Connection / Pipe Size	5/8 / 5/8	5/8 / 5/8
Indoor Unit Condensate Drain O.D. / I.D. (in.)	1-1/4 / 1		
Refrigerant Pre-Charge (oz.)	70.56	120.00	120.00
Additional Refrigerant Charge (oz./ft.)	0.43		
Pipe Length (Minimum / Maximum) (ft.)	16.4 / 164	16.4 / 246	
Piping Length ⁵ (no additional refrigerant, ft.)	24.6		
Maximum Elevation Difference (ft.)	98.4		

EEV: Electronic Expansion Valve, IDU: Indoor Unit, ODU: Outdoor Unit. Unit comes with a dry helium charge. This data is rated 0 ft above sea level, with 24.6 ft of refrigerant line per indoor unit and a 0 ft level difference between outdoor and indoor units.

Cooling capacity rating obtained with air entering the indoor coil at 80°F dry bulb (DB) and 67°F wet bulb (WB); and outdoor ambient conditions of 95°F dry bulb (DB) and 75°F wet bulb (WB). Heating capacity rating obtained with air entering the indoor unit at 70°F dry bulb (DB) and 60°F wet bulb (WB); and outdoor ambient conditions of 47°F dry bulb (DB) and 43°F wet bulb (WB).

¹Power Input is rated at high speed.

²All power wiring/communication cables from ODU to IDU are field supplied and are to be minimum 14

AWG, 4-conductor, stranded, shielded or unshielded (if shielded, must be grounded to chassis at ODU only), and must comply with applicable local and national codes.

³Take appropriate actions at the end of HVAC equipment life to recover, recycle, reclaim or destroy R410A refrigerant according to applicable regulations (40 CFR Part 82, Subpart F) under section 608 of CAA.

⁴Sound pressure levels are tested in an anechoic chamber under ISO Standard 3745.

⁵Piping lengths are equivalent.

⁶Cooling range can be extended from 5°F down to -4°F using the Low Ambient Wind Baffle Kit (sold separately).

ELECTRICAL DATA

Table 6: Electrical Data.

Nominal Tons	Unit Model No.	Hertz	Voltage	Voltage Range (Min. to Max.)	MCA	MOP	Compressor Quantity	Compressor Motor RLA (Cooling)	Condenser Fan Motor(s)	
									Condenser Fan Quantity.	Condenser Fan Motor FLA
<i>2 x 2 Four-Way Ceiling Cassettes</i>										
3/4	LUU090HV	60	208 - 230	187 - 253	11.9	15	1	9.0	1	0.2
1	LUU120HV				12.3					
1-1/2	LUU180HV				20	30		13.5		
<i>3 x 3 Four-Way Ceiling Cassettes</i>										
2	LUU240HV	60	208 - 230	187 - 253	20	30	1	13.5	1	1.6
3	LUU360HV				32	40		22	2	1.6 x 2
3-1/2	LUU420HV									

Voltage tolerance is ±10%.

Maximum allowable voltage unbalance is 2%.

RLA = Rated Load Amps.

MCA = Minimum Circuit Ampacity.

Maximum Overcurrent Protection (MOP) is calculated as follows: (Largest motor FLA x 2.25) + (Sum of other motor FLA) rounded down to the nearest standard fuse size.

FUNCTIONS, CONTROLS, AND OPTIONS

Table 7: Functions, Controls and Options.

System Type		2x2 Cassette (9, 12K)	2x2 Cassette (18K)	3x3 Cassette (24K, 36K, 42K)	
Airflow	Air Supply Outlets	4	4	4	
	Airflow Direction Control (Up and Down)	√ / Six (6) Steps	√ / Six (6) Steps	√ / Six (6) Steps	
	Auto Swing (Up and Down)	√	√	√	
	Airflow Steps (Fan / Cool / Heat)	4 / 5 / 4	4 / 5 / 4	4 / 5 / 5	
	Jet Cool / Jet Heat (Power Wind)	√ / -	√ / -	√ / √	
	Swirl Wind	√	√	√	
	Refresh Mode / Smart Mode	X / X	X / X	√ / √	
	Indirect Wind / Direct Wind	√ / √	√ / √	√ / √	
Filters	Pre-filter (Washable) ¹	√	√	√	
Oper.	Drain Pump	√	√	√	
	High Ceiling Operation ²	√	√	√	
	Auto Elevation Grille ²	X	X	√	
Reliability	Hot Start	√	√	√	
	Smart / Self Diagnosis	√	√	√	
	De-ice Control (Defrost)	√	√	√	
	Dry (Dehumidification) Operation	√	√	√	
	High Pressure Sensor	√	√	√	
	Phase Protection	X	X	X	
	Restart Delay (3-minutes)	√	√	√	
	Auto Changeover / Auto Restart	√	√	√	
Convenience	Auto Cleaning (Coil Dry)	√	√	√	
	Child Lock ²	√	√	√	
	Pump Down (Forced Cooling Operation, ODU)	X	√	√	
	Sleep Mode	√	√	√	
	Timer: 24 hour (On / Off) / 7 hour (Off)	√ / √	√ / √	√ / √	
	Timer: Weekly ²	√	√	√	
	Two Thermistor Control ²	√	√	√	
	Low Ambient Operation	X	√	√	
	Overheating Protection	√	√	√	
	ODU Silent Mode / Night Low Noise Operation	X	√	√	
	Indoor Unit Display Type	One LED	One LED	One LED	
	Indoor Unit Display Light	On / Off	On / Off	On / Off	
	Ener. Sav.	Energy Saving	√	√	√
		Energy Control	√	√	√
Netwk. Func.	Network Solution (LGAP)	X	√	√	
Controllers ³	Programmable Controllers (MultiSITE CRC*)	o (PREMTBVC2/C3/C4)			
	Simple Remote Controller	o (PREMTC00U) ³	o (PREMTC00U) ³	o (PREMTC00U) ³	
	Premium Remote Controller	o (PREMTB100/PREMTBB10) ³	o (PREMTB100/PREMTBB10) ³	o (PREMTB100/PREMTBB10) ³	
	Wireless Handheld Remote Controller	√ AKB73757604 (Also referenced by Model No. PQWRHQ0FDB)		√ AKB75735404	
	Remote Temperature Button Sensor	o (ZRTBS01)	o (ZRTBS01)	o (ZRTBS01)	
	Dry Contact	o (PDRYCB100 / 320 / 400)	o (PDRYCB100 / 320 / 400)	o (PDRYCB100 / 320 / 400)	
	AHU Communication Kit	o (PAHCMR000)	o (PAHCMR000)	o (PAHCMR000)	
	PI-485	X	o (PMNFP14A1)	o (PMNFP14A1)	
Cntl. Cont./ Integ. Sol.	AC Smart 5	X	o (PACS5A000)	o (PACS5A000)	
	ACP 5 BACnet Gateway	X	o (PACP5A000)	o (PACP5A000)	
	MultiSITE Communications Manager	X	o (PBACNBTR0A)	o (PBACNBTR0A)	
	LonWorks Gateway	X	o (ZHWLONWK0)	o (ZHWLONWK0)	
Special Function	Aux. Heat Relay Kit	o (PRARH1)	o (PRARH1)	o (PRARH1)	
	Wi-Fi ⁴	o (PWFMD200)	o (PWFMD200)	o (PWFMD200)	
	Wind Baffle Kit	o (ZLABGP01A)	o (ZLABGP04A)	o (ZLABGP04A)	
	Sheath Heater (Drain Pan Heater)	√ (PQSH1202)	√ (PQSH1200)	√ (PQSH1200)	
Other	Mode Lock	X	Cooling Only or Heating Only	Cooling Only or Heating Only	
	Temperature Control	√	√	√	

√ = Standard feature o = Unit option 1Primary washable filter. 14"x14"x1" for 2x2 units; 20.5"x20.5"x1" for 3x3 units. 3Not all controllers can support all features. Contact your LG representative for details. 4Requires Wi-Fi module PWFMD200. X = Not Available 2Requires wired zone controller.



OUTDOOR UNIT DIMENSIONS

LUU090HV, LUU120HV

Figure 4: LUU090HV, LUU120HV Outdoor Unit Dimensions.

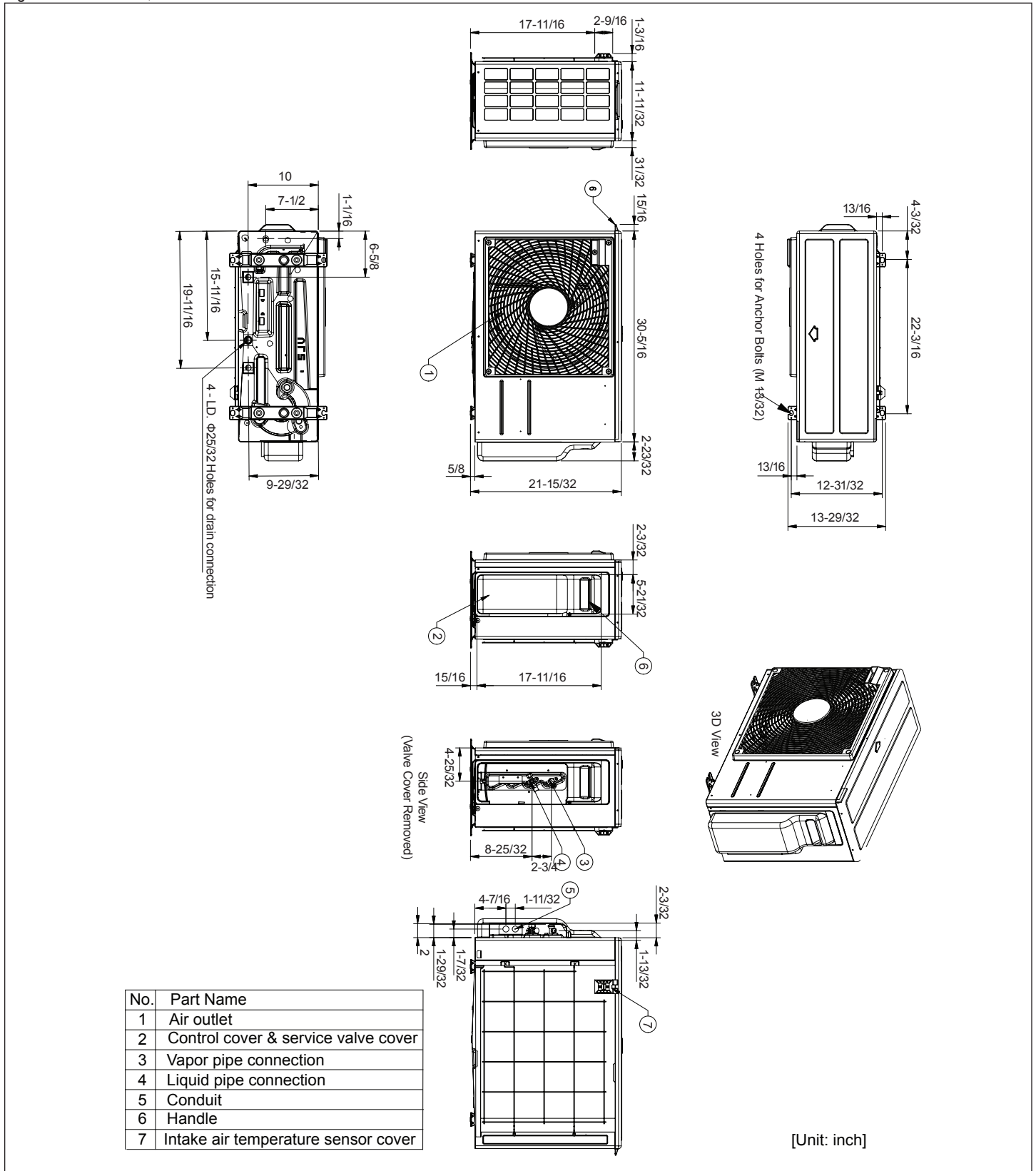

OUTDOOR UNIT DIMENSIONS

LUU180HV, LUU240HV

Figure 5: LUU180HV, LUU240HV Outdoor Unit Dimensions.

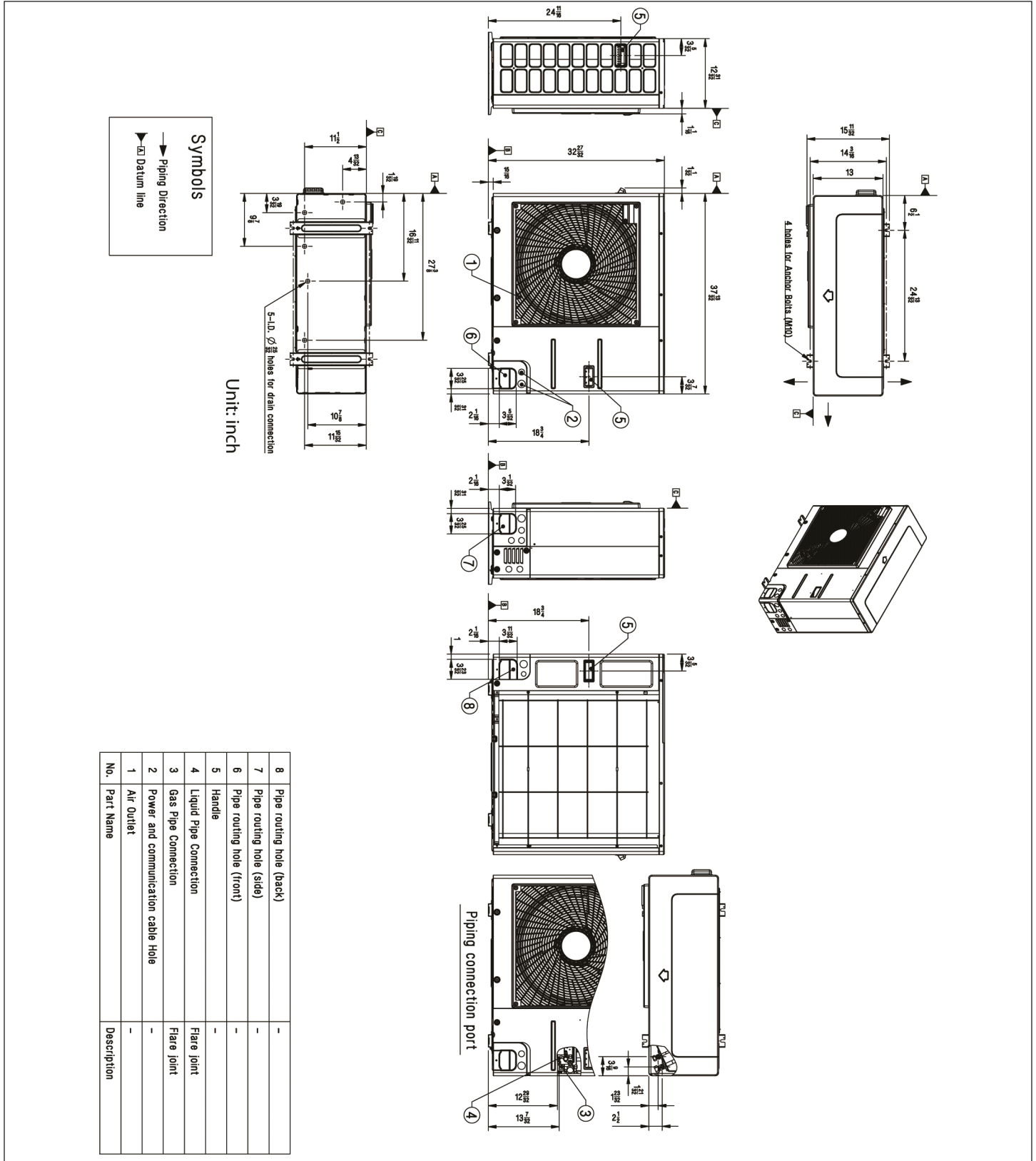

OUTDOOR UNIT DIMENSIONS

LUU360HV, LUU420HV

Figure 6: LUU360HV, LUU420HV Outdoor Unit Dimensions.

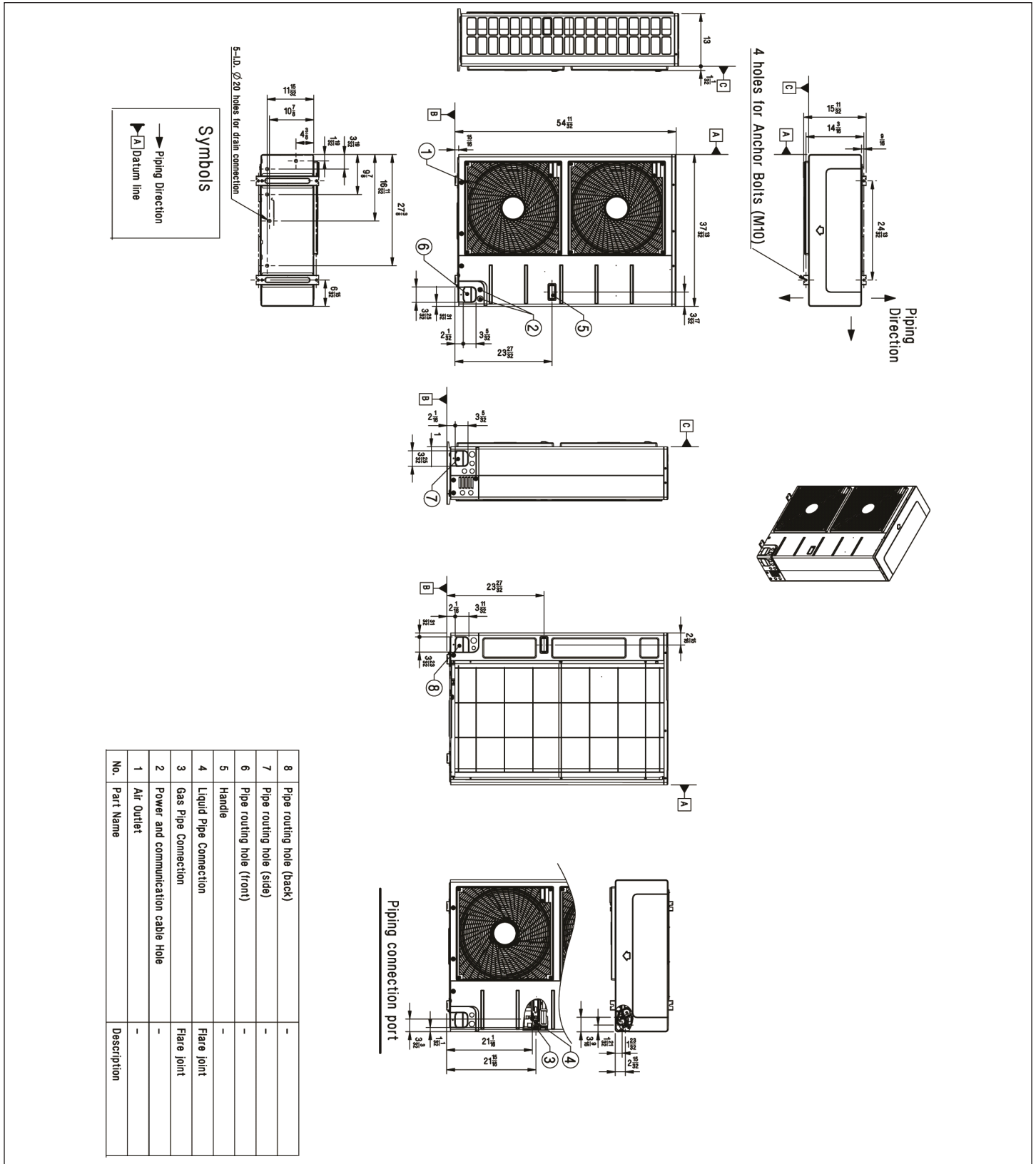

INDOOR UNIT DIMENSIONS

LCN098HV4, LCN128HV4

Figure 7: LCN098HV4, LCN128HV4 Indoor Unit Dimensions.

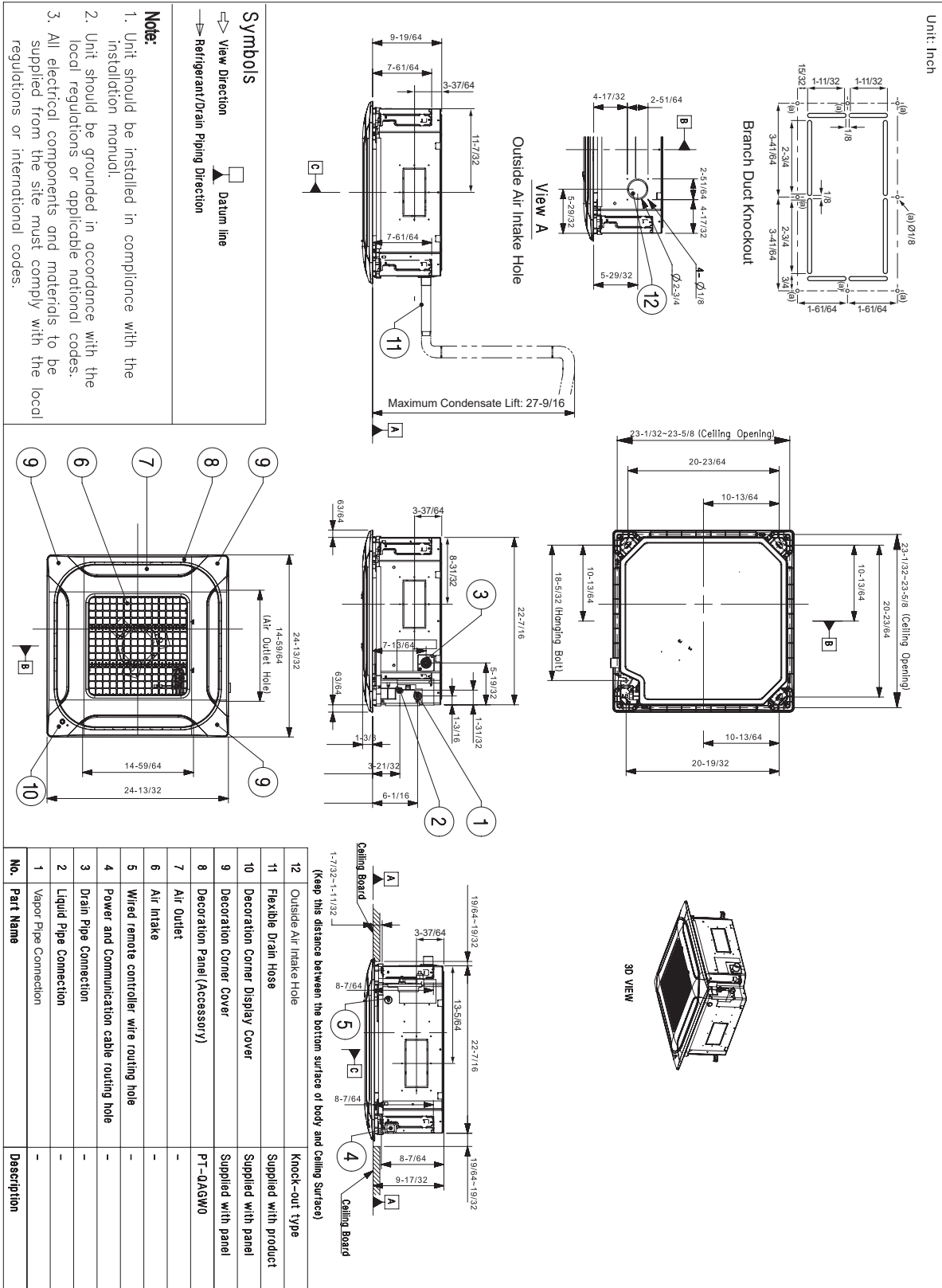

INDOOR UNIT DIMENSIONS

LCN188HV4

Figure 8: LCN188HV4 Indoor Unit Dimensions.

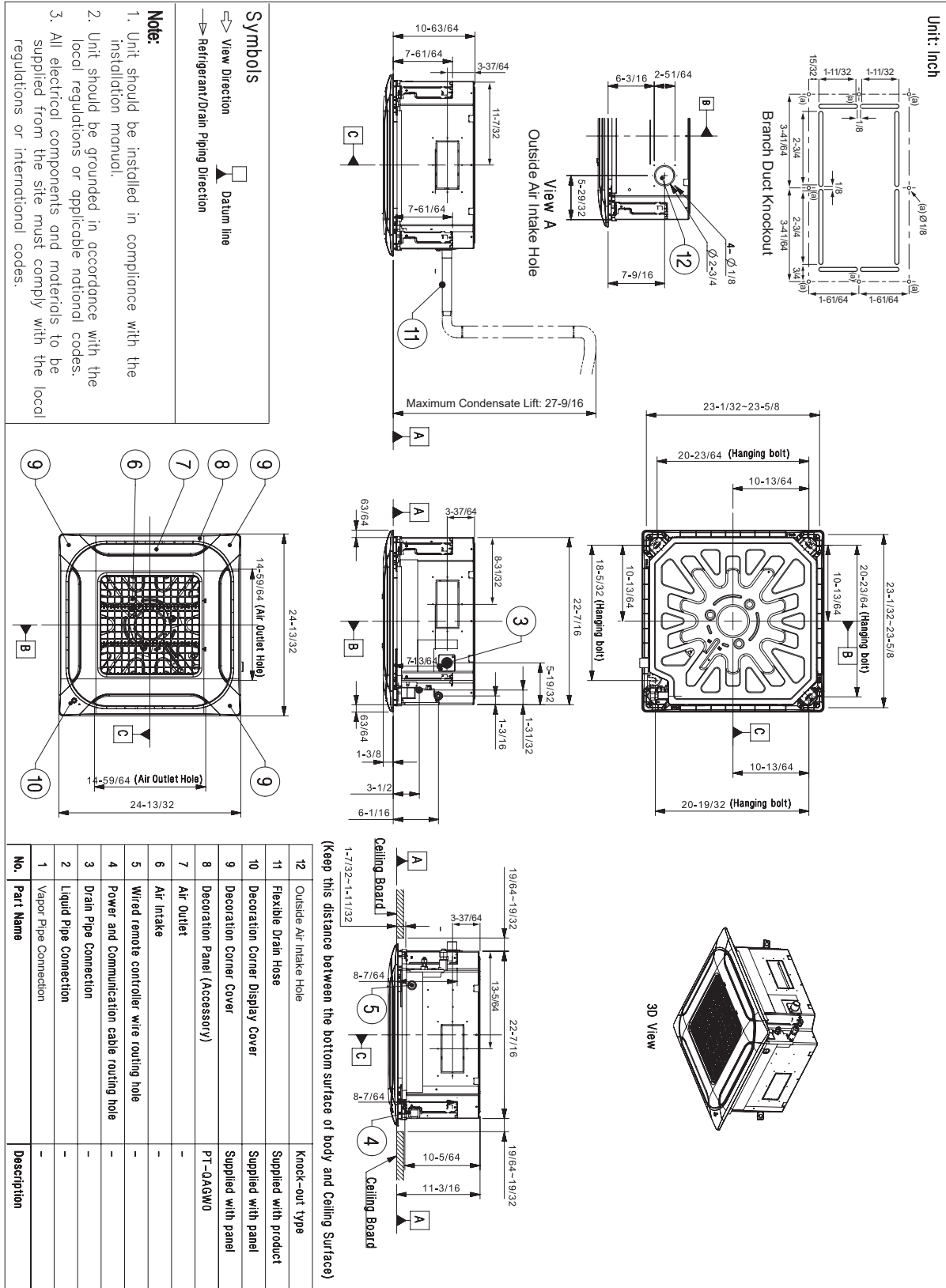

INDOOR UNIT DIMENSIONS

LCN249HV

Figure 9: LCN249HV Indoor Unit Dimensions.

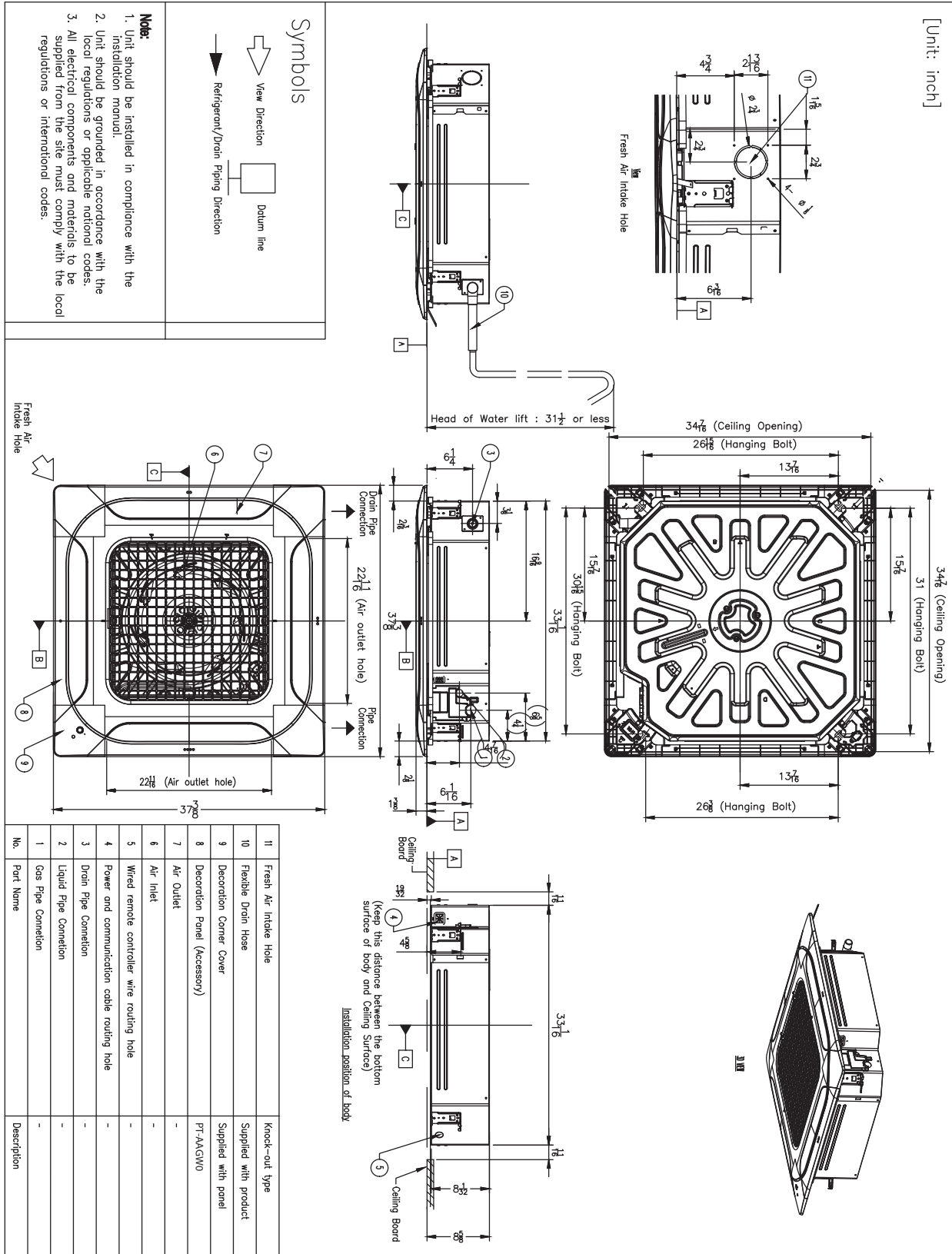

ACOUSTIC DATA

Indoor Units

Figure 11: Indoor Unit Sound Pressure Level Measurement Location.

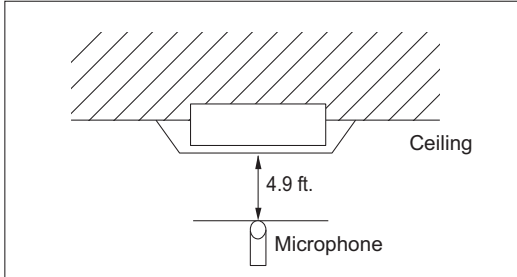

- Measurements taken with no attenuation and units operating at full load normal operating condition.
- Sound level will vary depending on a range of factors such as construction (acoustic absorption coefficient) of particular area in which the equipment is installed.
- Sound pressure levels are measured in dB(A)±1.
- Tested in anechoic chamber per ISO Standard 3745.

Table 8: Four-Way Ceiling Cassette Indoor Unit Sound Levels (dB[A]).

Model	Sound Pressure Levels (dB[A])			Sound Power Levels (dB[A])
	H	M	L	H
LCN098HV4	36	33	30	-
LCN128HV4	38	35	32	-
LCN188HV4	43	41	38	-
LCN249HV	40	37	35	57
LCN369HV	44	42	41	61
LCN429HV	46	43	41	62

Figure 12: Four-Way Ceiling Cassette Indoor Unit Sound Pressure Level Diagrams.

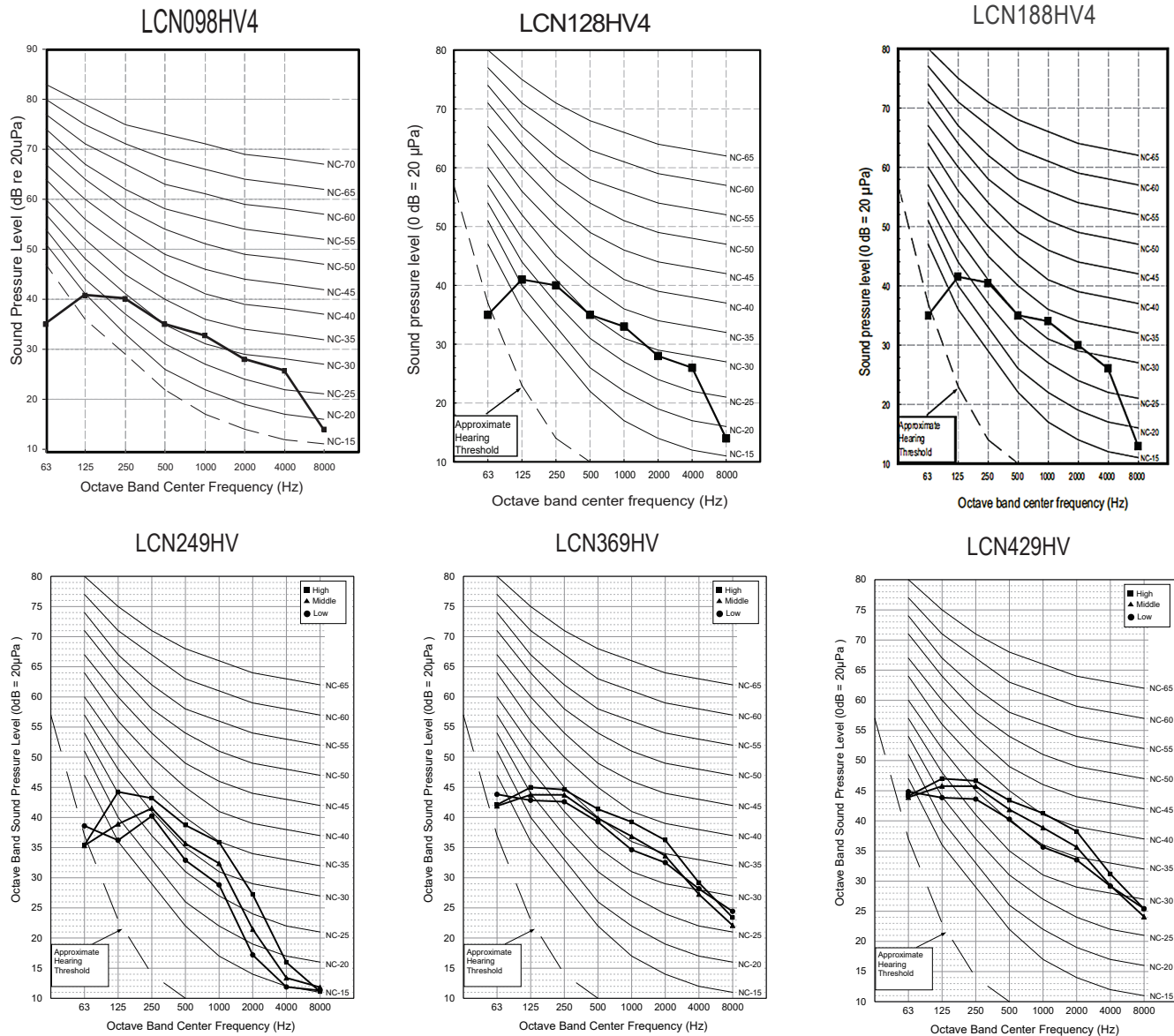

Product Data

ACOUSTIC DATA

Indoor Units

Figure 13: Four-Way Ceiling Cassette Indoor Unit Sound Power Level Diagrams.

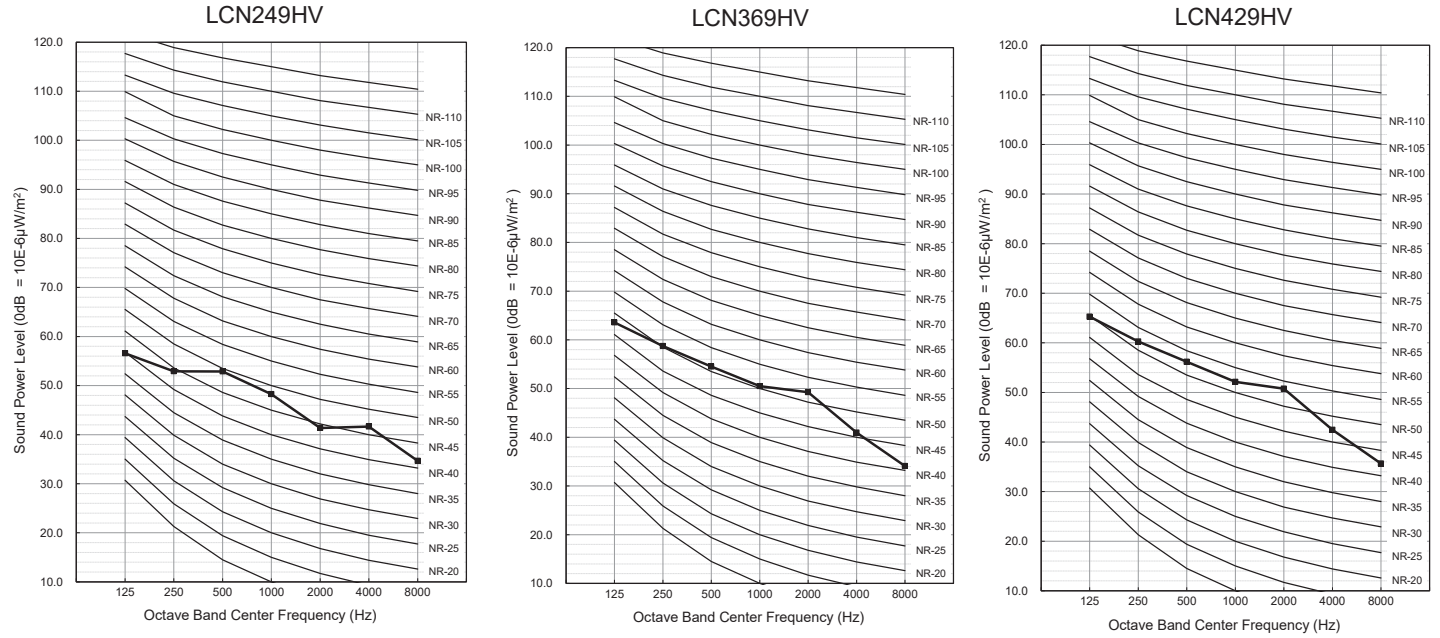

ACOUSTIC DATA

Outdoor Units

Figure 14: Four-Way Ceiling Cassette Outdoor Unit Sound Pressure Level Measurement Location.

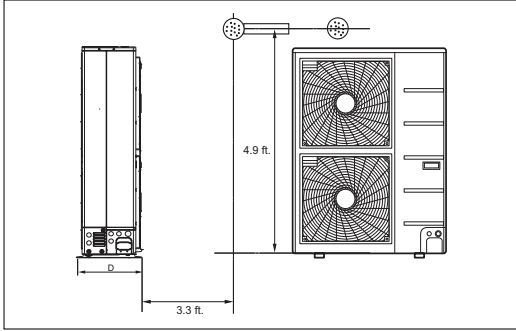

Figure 15: Four-Way Ceiling Cassette Outdoor Unit Sound Pressure Level Diagrams.

- Measurements taken with no attenuation and units operating at full load normal operating condition.
- Sound level will vary depending on a range of factors such as construction (acoustic absorption coefficient) of particular area in which the equipment is installed.
- Sound pressure levels are measured in dB(A)±1.
- Tested in anechoic chamber per ISO Standard 3745.

Table 9: Four-Way Ceiling Cassette Outdoor Unit Sound Levels (dB[A]).

Model	Sound Pressure Levels (dB[A])		Sound Power Levels (dB[A])
	Cooling	Heating	
LUU090HV	47	51	-
LUU120HV	49	52	-
LUU180HV	48	52	67
LUU240HV	48	52	67
LUU360HV	52	54	65
LUU420HV	52	54	66

LUU090HV

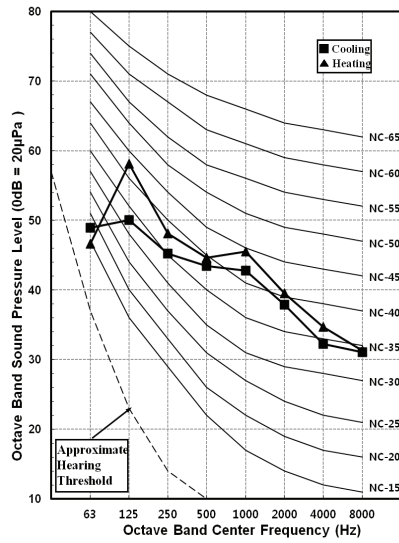

LUU120HV

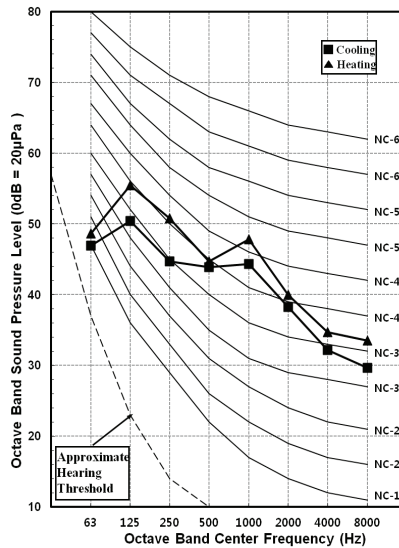

LUU180HV

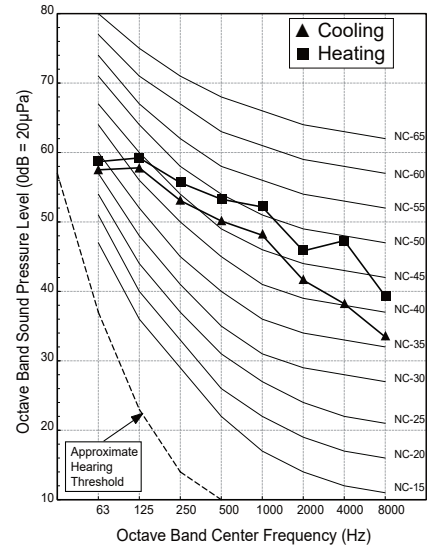

LUU240HV

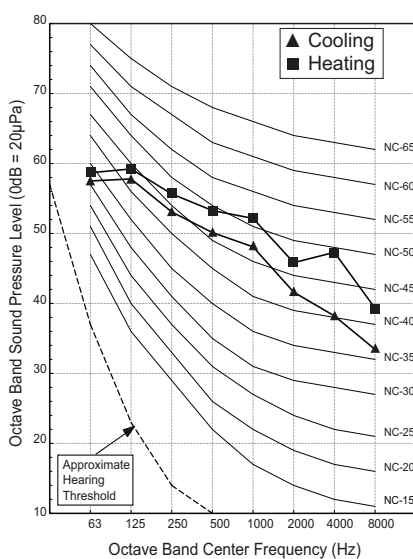

LUU360HV, LUU420HV

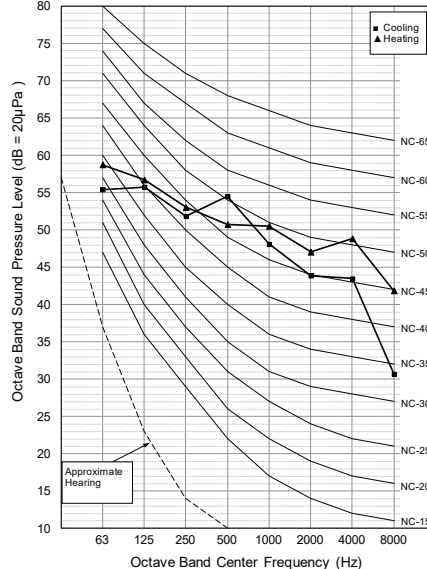

ACOUSTIC DATA

Outdoor Units

Figure 16: Four-Way Ceiling Cassette Outdoor Unit Sound Power Level Diagrams.

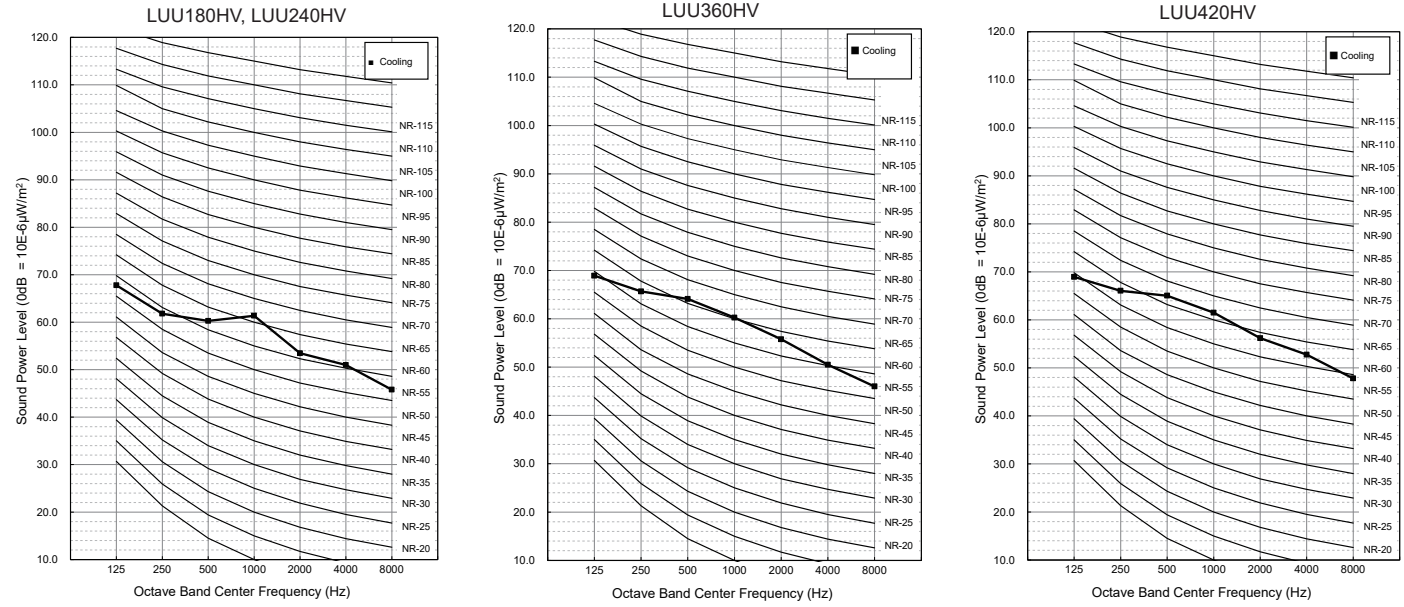

REFRIGERANT FLOW DIAGRAMS

LCN098HV4, LCN128HV4 Indoor Units

Figure 17: LCN098HV4, LCN128HV4 Refrigerant Flow Diagram.

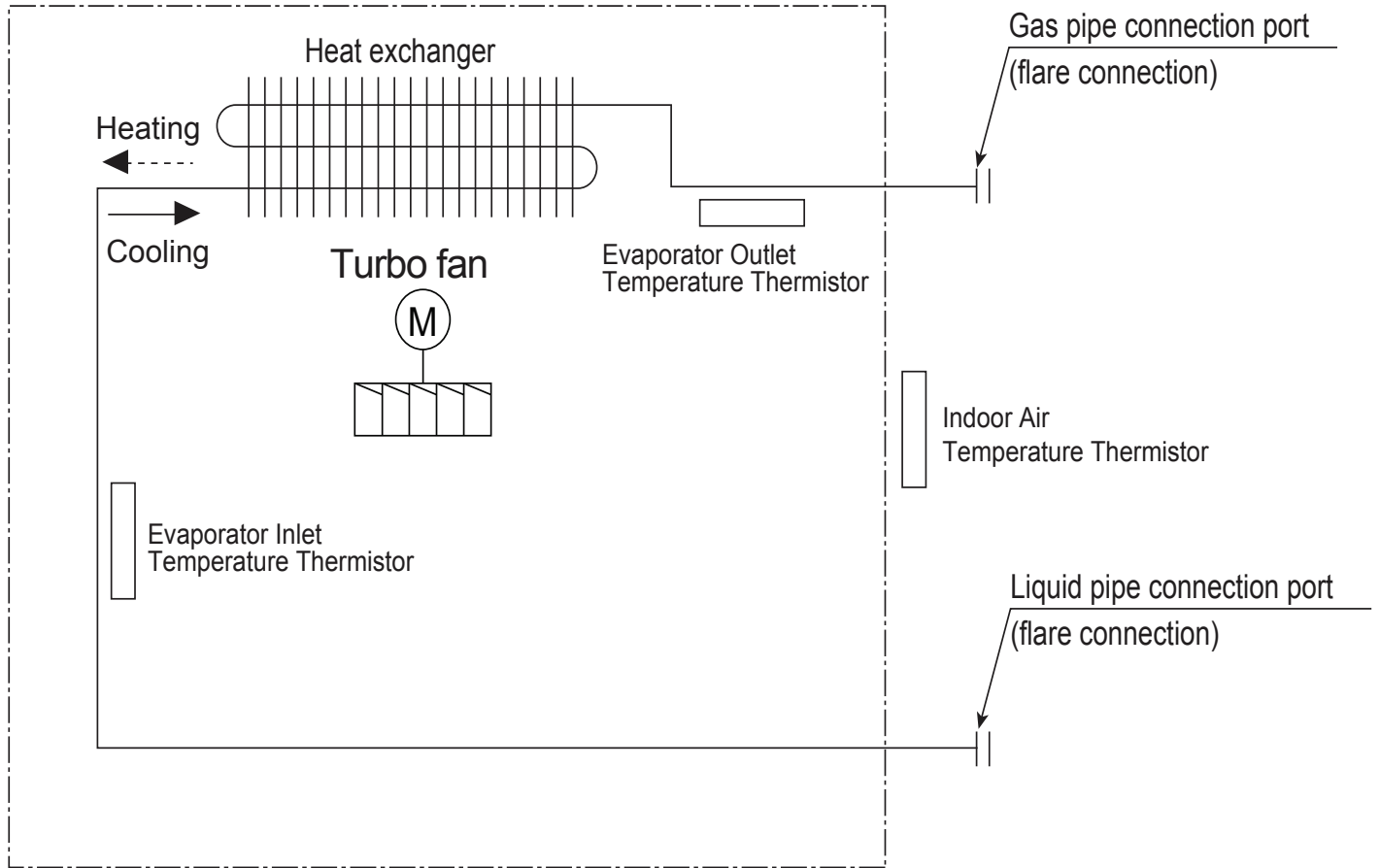

Product Data

Table 10: LCN098HV4, LCN128HV4 Four-Way Ceiling Cassette Indoor Unit Thermistor Details.

Description (Based on Cooling Mode)	PCB Connector
Indoor Air Temperature Thermistor	CN-ROOM
Evaporator Inlet Temperature Thermistor	CN-PIPE / IN
Evaporator Outlet Temperature Thermistor	CN-PIPE / OUT

Table 11: LCN098HV, LCN128HV4 Four-Way Ceiling Cassette Indoor Unit Refrigerant Pipe Connections.

Model No.	Vapor (inch)	Liquid (inch)
LCN098HV4, LCN128HV4	3/8	1/4

Table 12: LCN098HV, LCN128HV4 Four-Way Ceiling Cassette Indoor Unit Refrigerant Pipe Sizes.

Model No.	Vapor (inch)	Liquid (inch)
LCN098HV4, LCN128HV4	3/8	1/4

REFRIGERANT FLOW DIAGRAMS

LCN188HV4 Indoor Units

Figure 18: LCN188HV4 Refrigerant Flow Diagram.

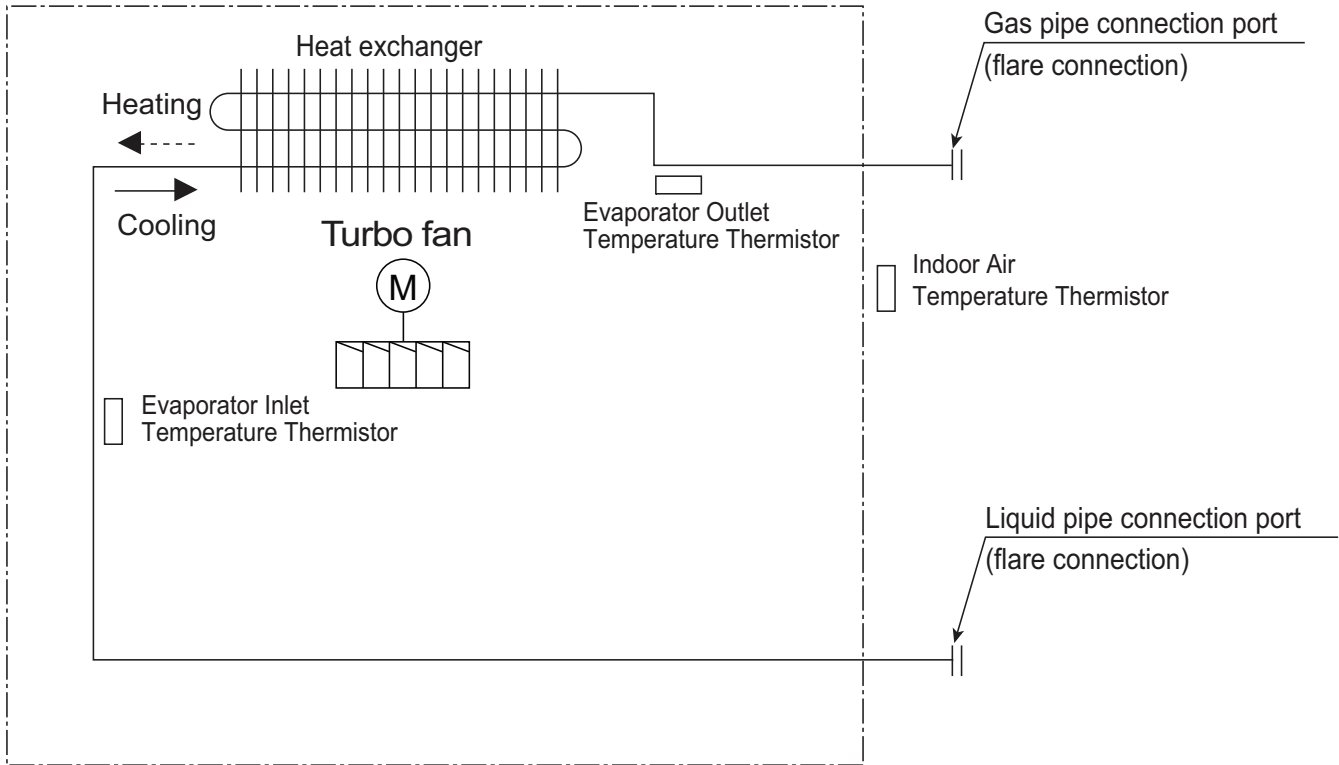

Table 13: LCN188HV4 Four-Way Ceiling Cassette Indoor Unit Thermistor Details.

Description (Based on Cooling Mode)	PCB Connector
Indoor Air Temperature Thermistor	CN-ROOM
Evaporator Inlet Temperature Thermistor	CN-PIPE / IN
Evaporator Outlet Temperature Thermistor	CN-PIPE / OUT

Table 14: LCN188HV4 Four-Way Ceiling Cassette Indoor Unit Refrigerant Pipe Connections.

Model No.	Vapor (inch)	Liquid (inch)
LCN188HV4	1/2	1/4

Table 15: LCN188HV4 Four-Way Ceiling Cassette Indoor Unit Refrigerant Pipe Sizes.

Model No.	Vapor (inch)	Liquid (inch)
LCN188HV4	5/8	3/8

Table 16: LCN188HV4 Connection Socket Dimensions.

Model No.	Vapor (inch)	Liquid (inch)
LCN188HV4	Ø1/2 – Ø5/8	Ø1/4 – Ø3/8

Figure 19: LCN188HV4 Refrigerant Pipe Connections.

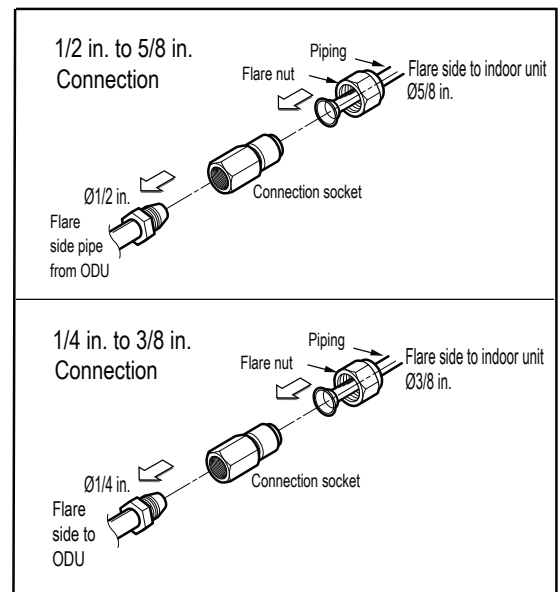

REFRIGERANT FLOW DIAGRAMS

LCN249HV, LCN369HV, LCN429HV Indoor Units

Figure 20: LCN249HV, LCN369HV, LCN429HV Refrigerant Flow Diagram.

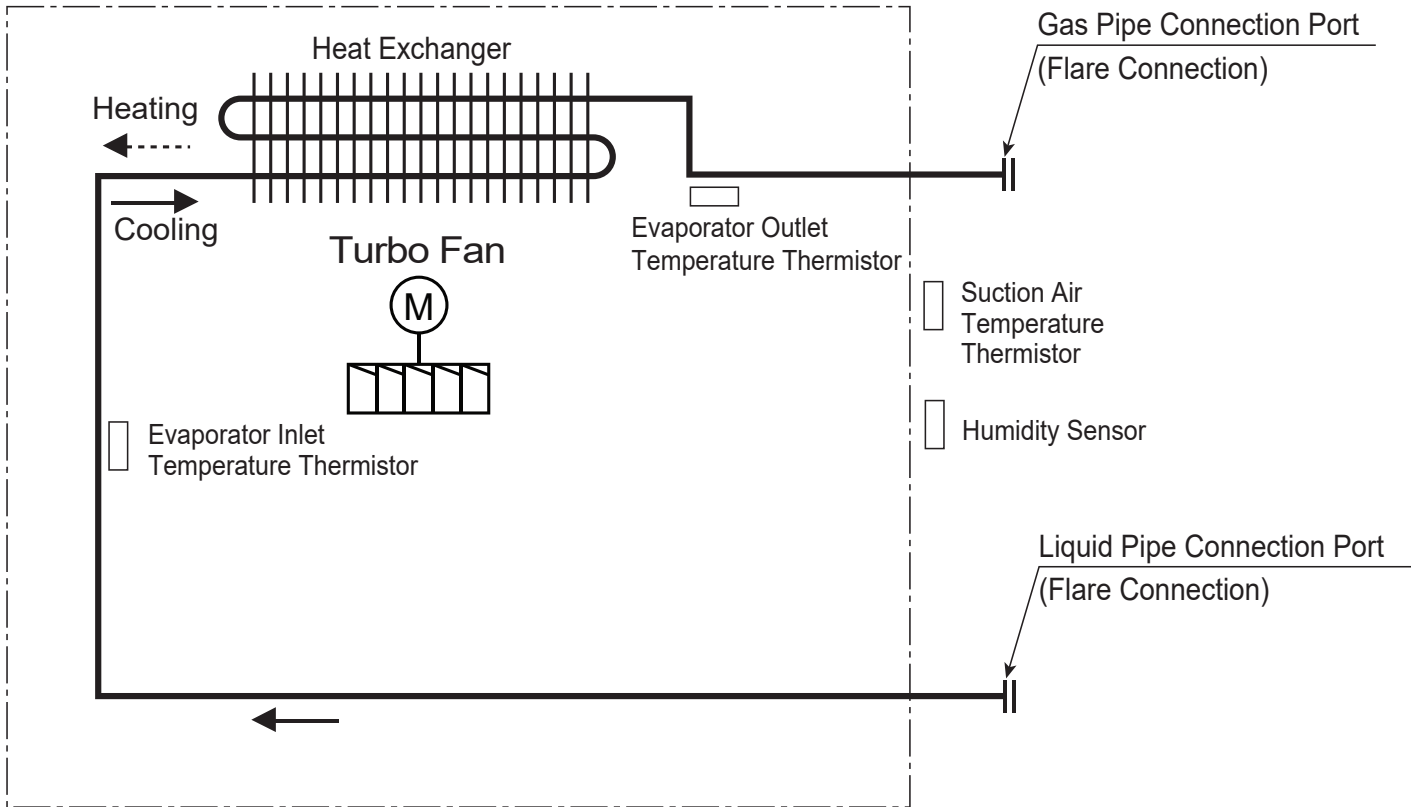

Product Data

Table 17: LCN249HV, LCN369HV, LCN429HV Four-Way Ceiling Cassette Indoor Unit Thermistor Details.

Description (Based on Cooling Mode)	PCB Connector
Suction Air Temperature Thermistor	CN_ROOM
Evaporator Inlet Temperature Thermistor	CN_PIPE_IN
Evaporator Outlet Temperature Thermistor	CN_PIPE_OUT
Humidity Sensor	CN_ROOM_HUMID

Table 18: LCN249HV, LCN369HV, LCN429HV Four-Way Ceiling Cassette Indoor Unit Refrigerant Pipe Connections.

Model No.	Vapor (inch)	Liquid (inch)
LCN249HV, LCN369HV, LCN429HV	5/8	3/8

Table 19: LCN249HV, LCN369HV, LCN429HV Four-Way Ceiling Cassette Indoor Unit Refrigerant Pipe Sizes.

Model No.	Vapor (inch)	Liquid (inch)
LCN249HV, LCN369HV, LCN429HV	5/8	3/8

REFRIGERANT FLOW DIAGRAMS

LUU090HV, LUU120HV Outdoor Units

Figure 21: LUU090HV, LUU120HV Refrigerant Flow Diagram.

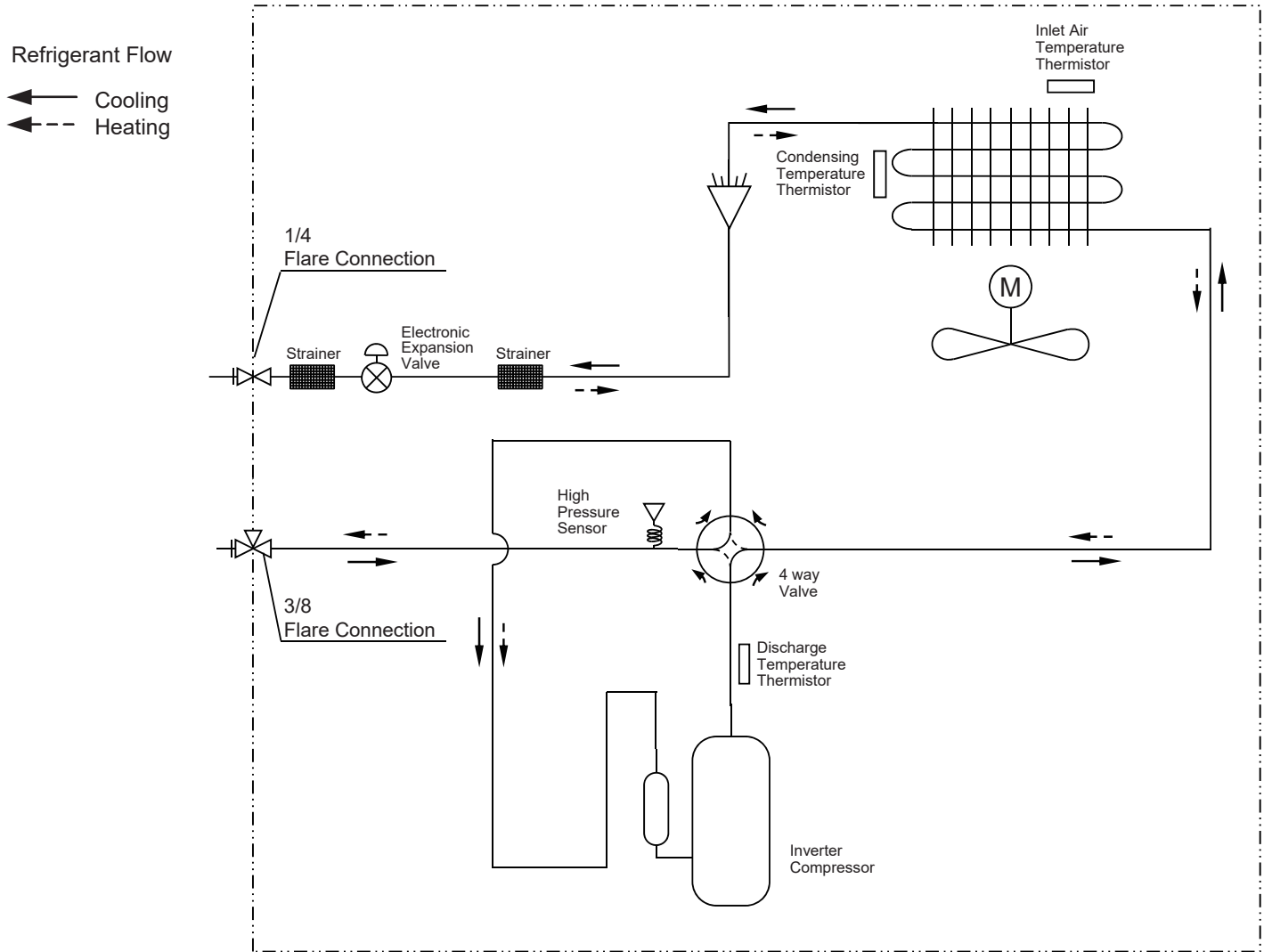

Table 20: LUU090HV, LUU120HV Four-Way Ceiling Cassette Outdoor Unit Thermistor Details.

Description	PCB Connector
Condenser Inlet Temperature Thermistor	CN-AIR
Discharge Temperature Thermistor	CN-DISCHARGE
Condensing Temperature Thermistor	CN-MID
High Pressure Sensor	CN-H_PRESSURE
Electronic Expansion Valve	CN-EEV_A

REFRIGERANT FLOW DIAGRAMS

LUU180HV, LUU240HV, LUU360HV, LUU420HV Outdoor Units

Figure 22: LUU180HV, LUU240HV, LUU360HV, LUU420HV Refrigerant Flow Diagram.

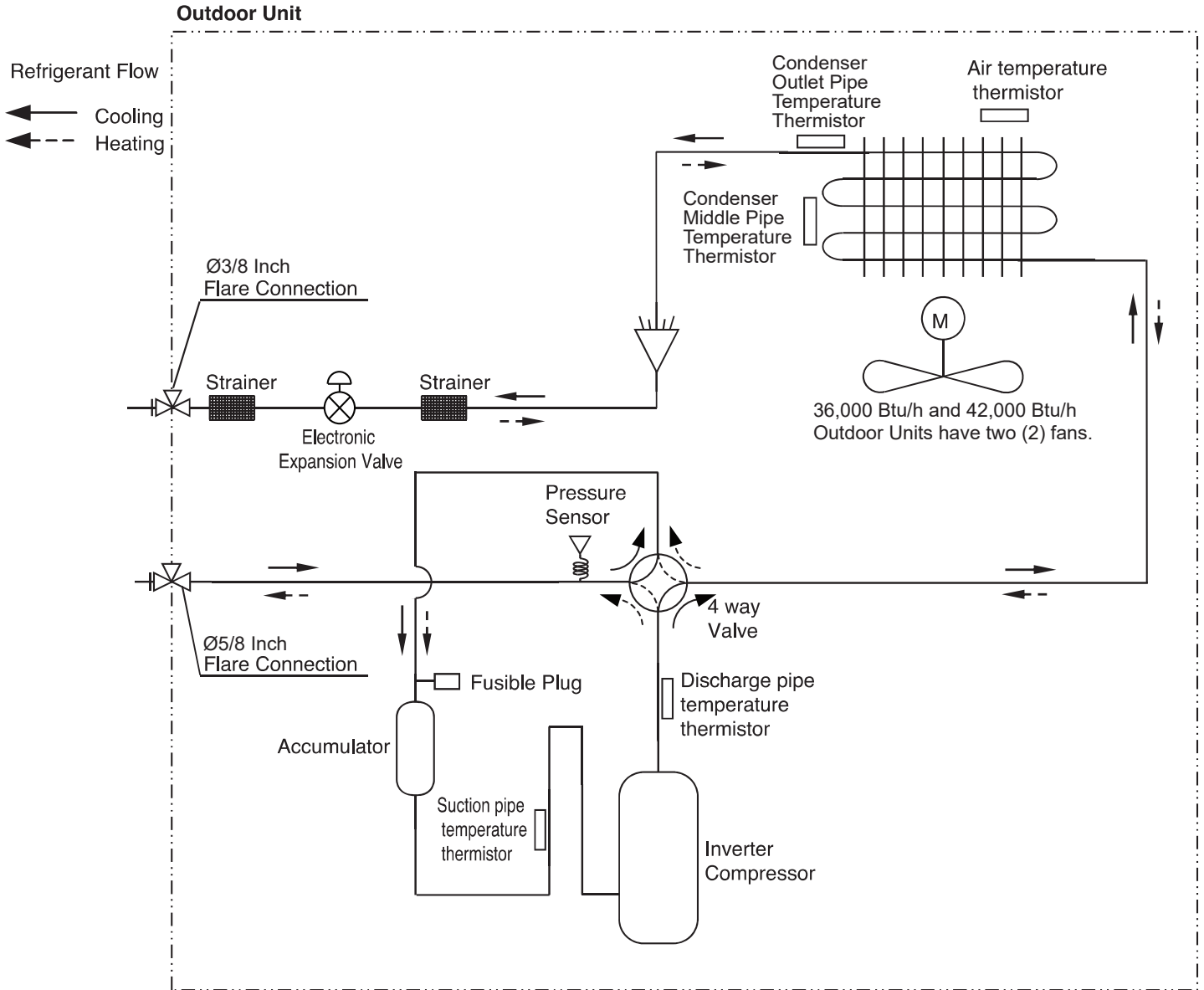

Product Data

Table 21: LUU180HV, LUU240HV, LUU360HV, LUU420HV Four-Way Ceiling Concealed Outdoor Unit Thermistor Details.

Description	PCB Connector
Discharge Pipe Temperature Thermistor	CN_DISCHA_BK
Suction Pipe Temperature Thermistor	CN_SUCTION_GR
Condenser Outlet Pipe Temperature Thermistor	CN_C_PIPE_VI
Air Temperature Thermistor	CN_AIR_YL
Condenser Middle Pipe Temperature Thermistor	CN_MID_BR
Pressure Sensor	CN_H_PRESS_RD

WIRING DIAGRAMS

LCN098HV4, LCN128HV4, LCN188HV4 Indoor Units

Figure 23: LCN098HV4, LCN128HV4, LCN188HV4 Four-Way Ceiling Cassette Indoor Unit Wiring Diagram.

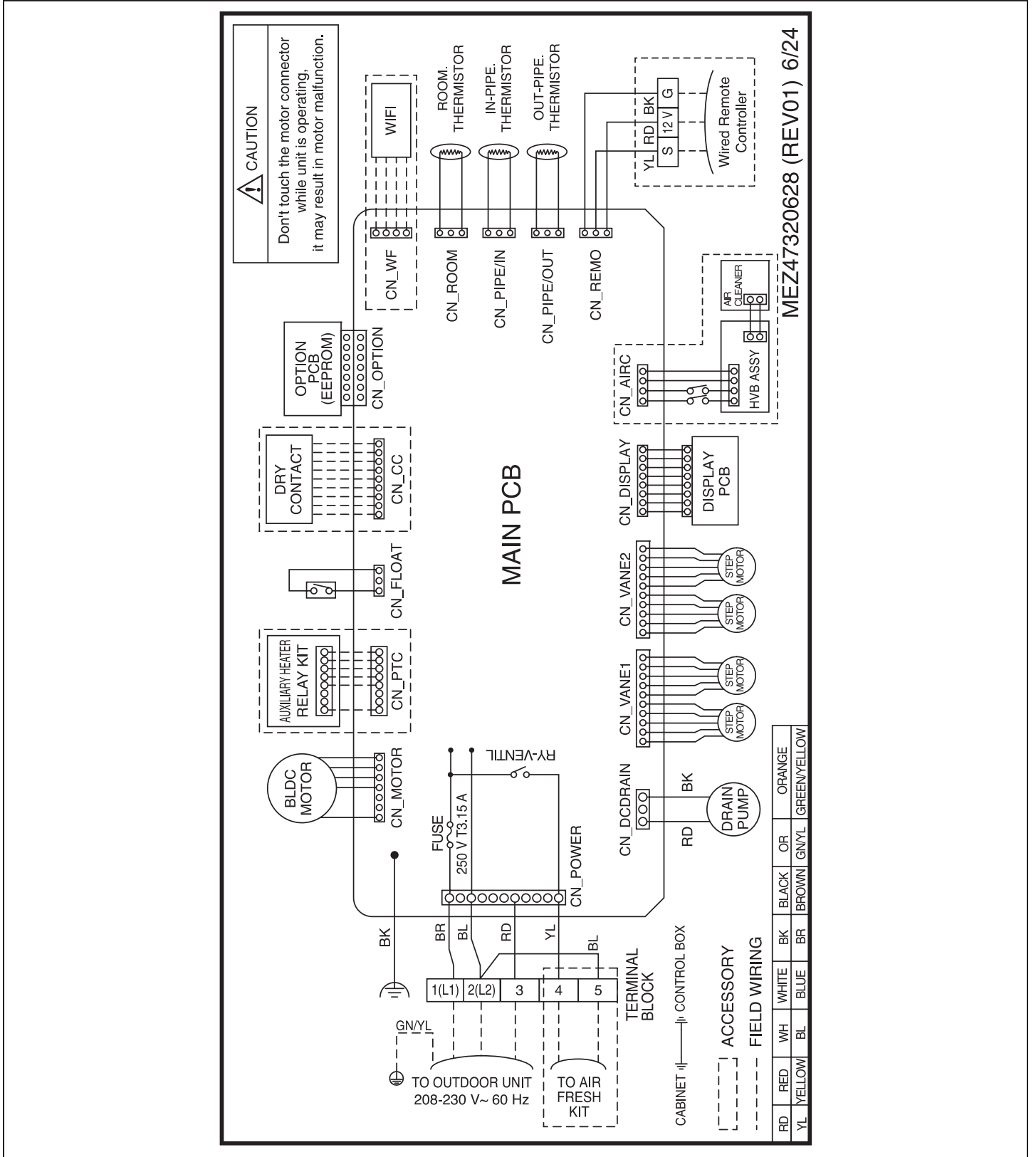

WIRING DIAGRAMS

LCN249HV, LCN369HV Indoor Units

Figure 24: LCN249HV, LCN369HV Four-Way Ceiling Cassette Indoor Unit Wiring Diagram.

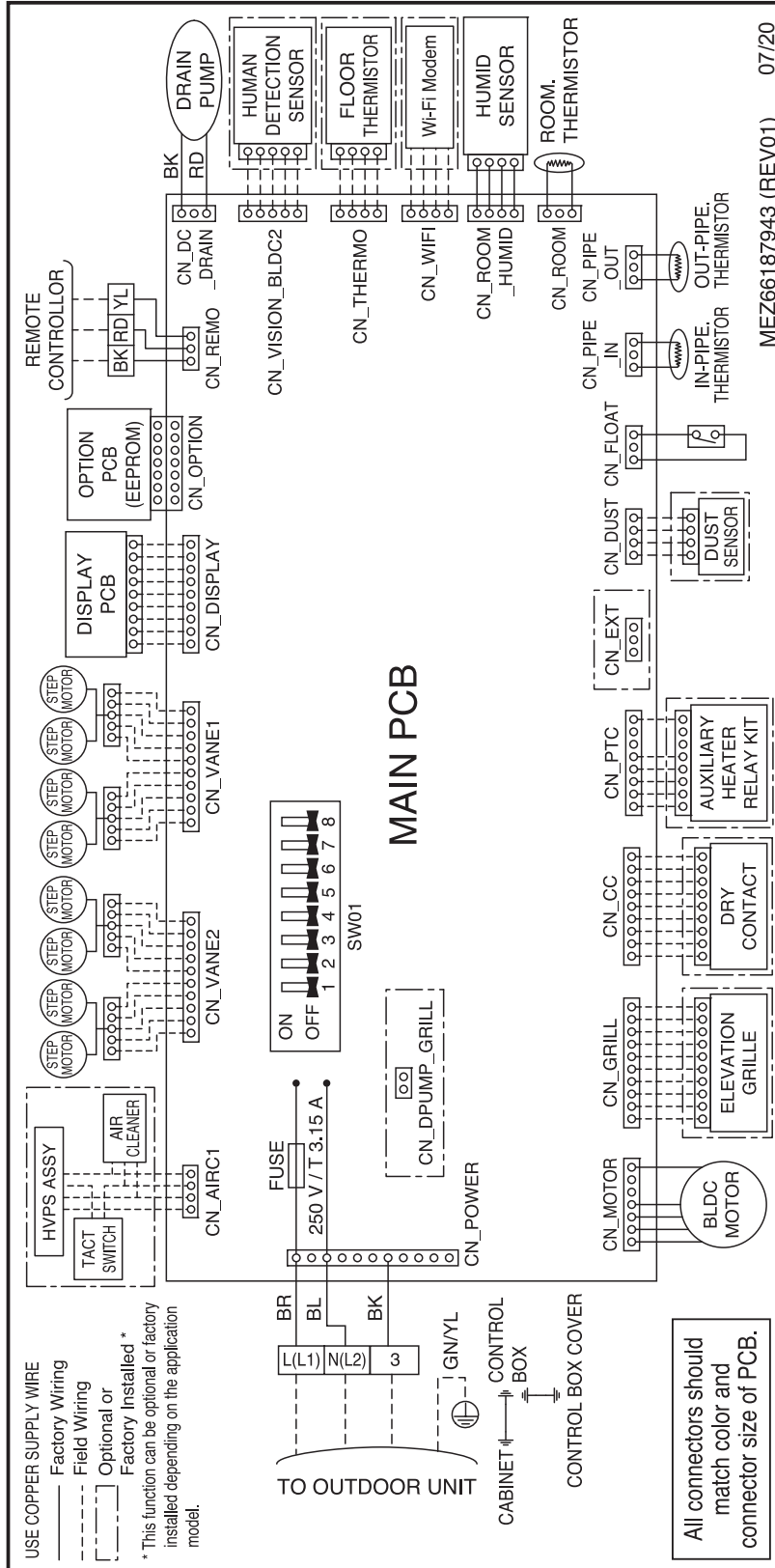

Product Data

WIRING DIAGRAMS

LCN429HV Indoor Units

Figure 25: LCN429HV Four-Way Ceiling Cassette Indoor Unit Wiring Diagram.

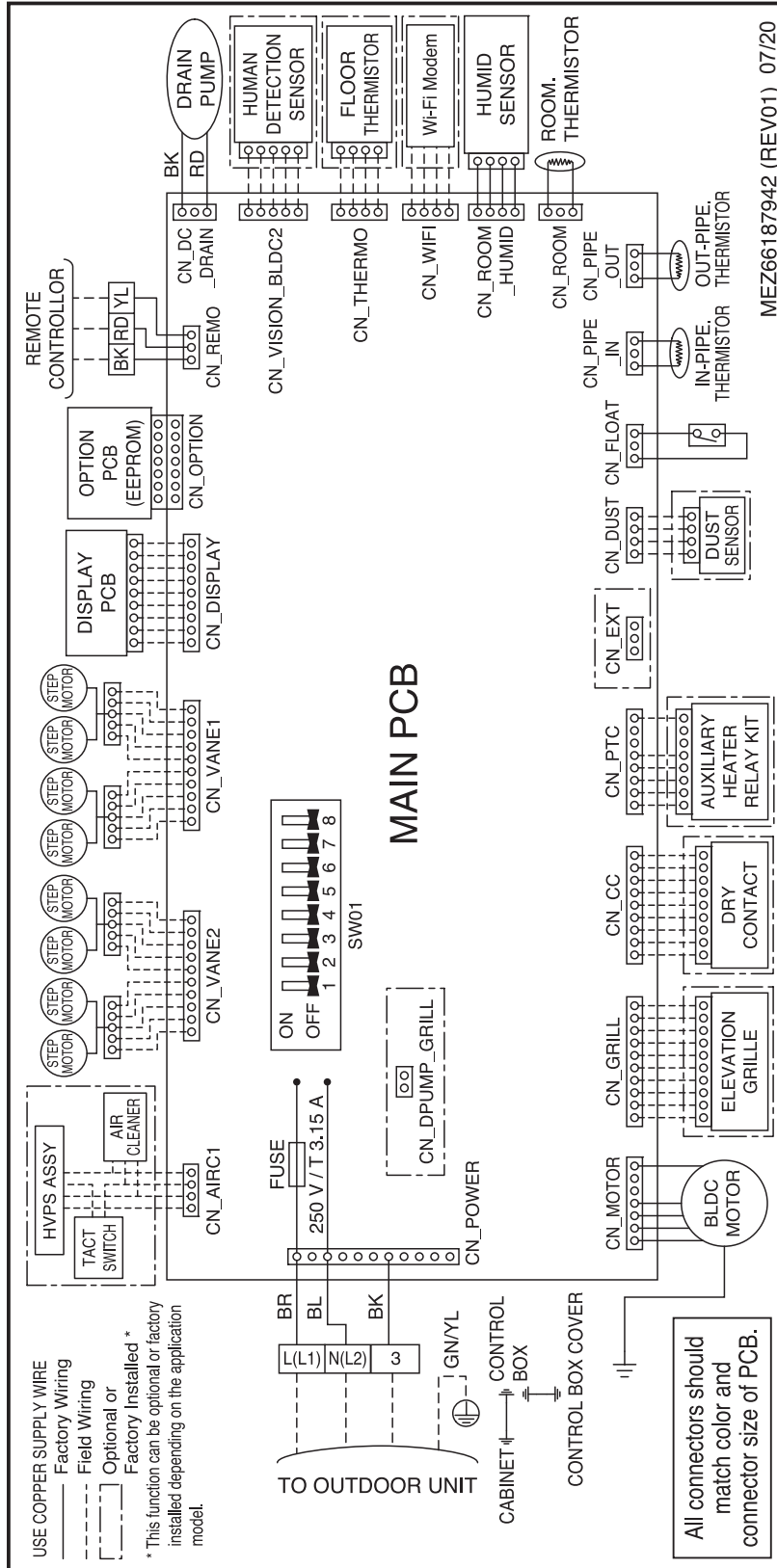

Due to our policy of continuous product innovation, some specifications may change without notification.
 © LG Electronics U.S.A., Inc., Englewood Cliffs, NJ. All rights reserved. "LG" is a registered trademark of LG Corp.

WIRING DIAGRAMS

LUU090HV, LUU120HV Outdoor Units

Figure 26: LUU090HV, LUU120HV Four-Way Ceiling Cassette Outdoor Unit Wiring Diagram.

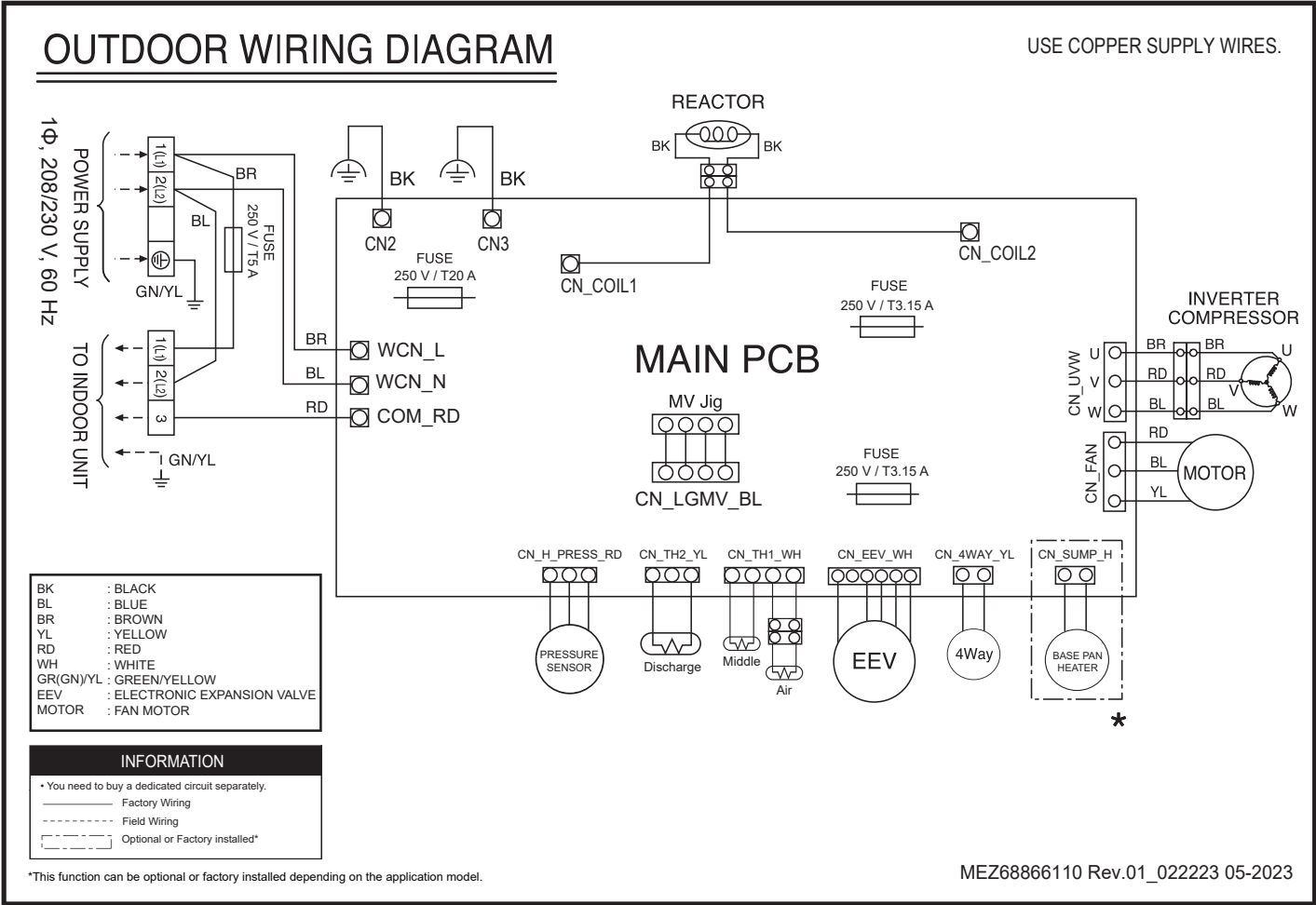

Product Data

WIRING DIAGRAMS

LUU180HV, LUU240HV Outdoor Units

Figure 27: LUU180HV, LUU240HV Four-Way Ceiling Cassette Outdoor Unit Wiring Diagram.

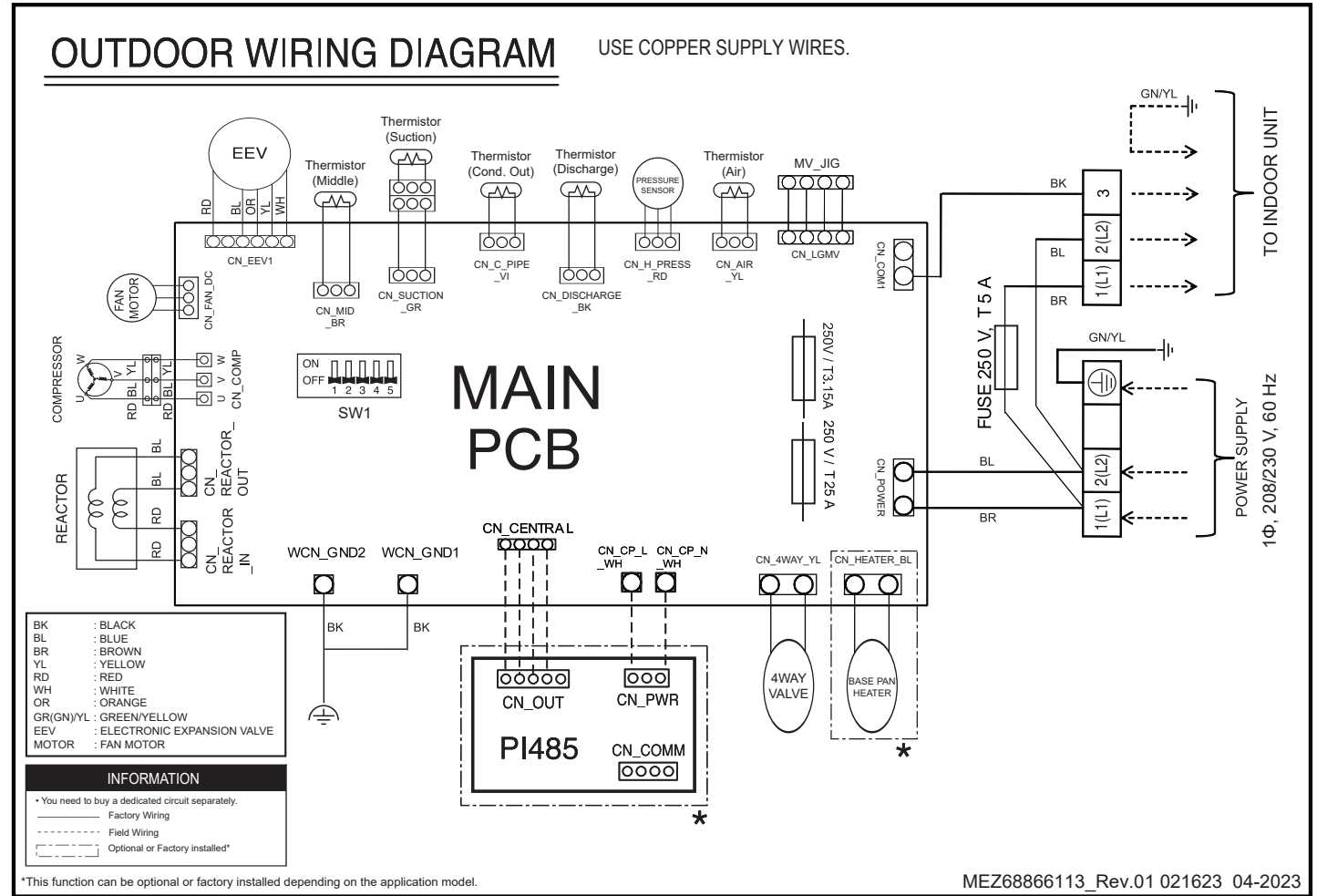

WIRING DIAGRAMS

LUU360HV, LUU420HV Outdoor Units

Figure 28: LUU360HV, LUU420HV Four-Way Ceiling Cassette Outdoor Unit Wiring Diagram.

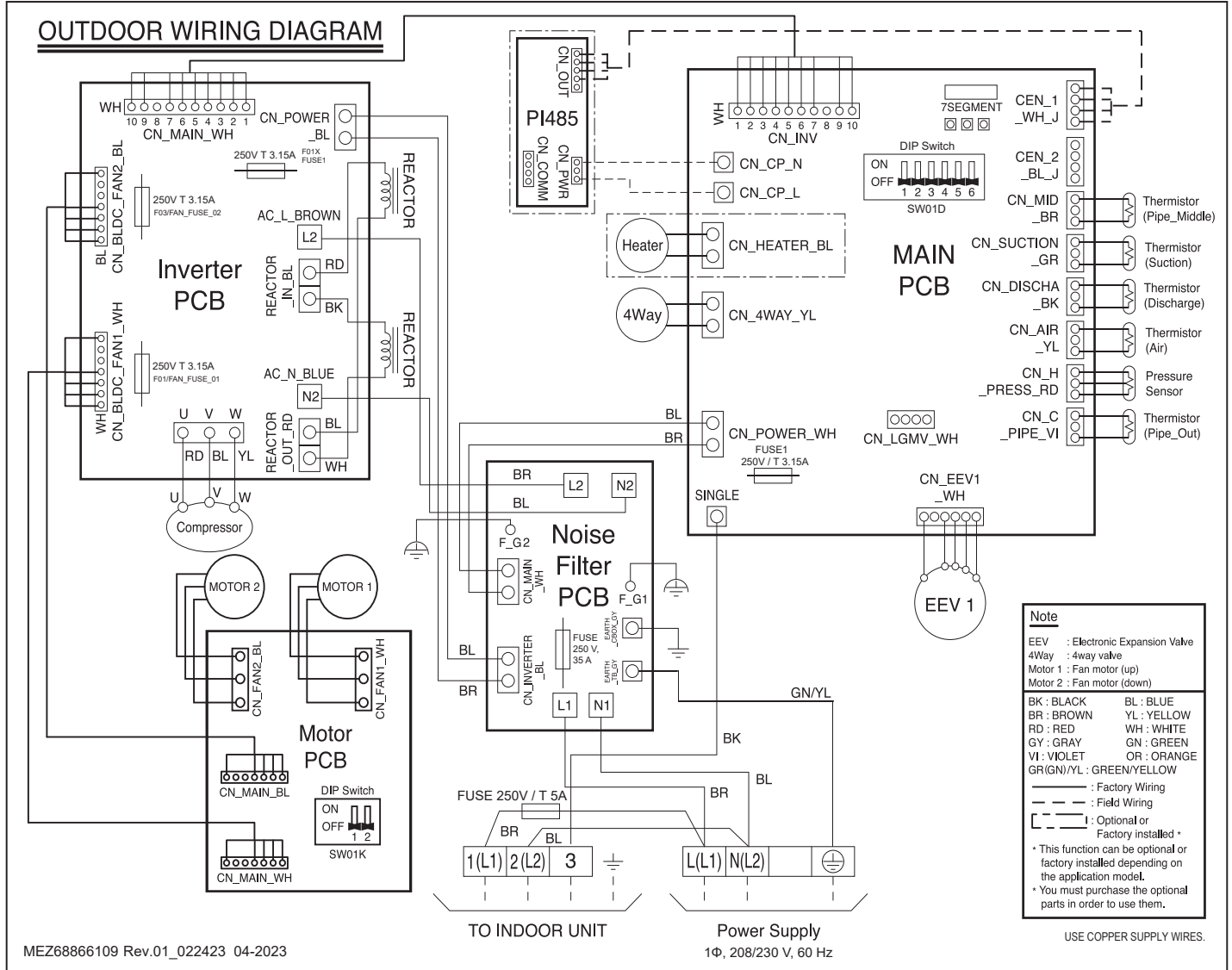

ELECTRICAL CONNECTIONS

General Power Wiring / Communications Cable Guidelines

- Follow manufacturer's circuit diagrams displayed on the inside of the control box cover.
- Confirm power source specifications.
- Properly ground the ODU and the IDU per National Electrical Code (NEC) and local codes.
- Connect the wiring firmly so that the wires cannot be easily pulled out.
- Confirm that the electrical capacity is sufficient.
- Power supply to the outdoor unit must be selected based on NEC and local codes. Maximum allowable voltage fluctuation $\pm 10\%$ or nameplate rated value.
- It is recommended that a circuit breaker is installed, especially if conditions could become wet or moist.
- Include a disconnect in the power wiring system. Add an air gap contact separation of at least 1/8 inch in each active (phase) conductor.
- Any openings where the field wiring enters the cabinet must be completely sealed.

Figure 29: General Four-Way Ceiling Cassette System Power / Communications System Schematic (Appearances May Vary).

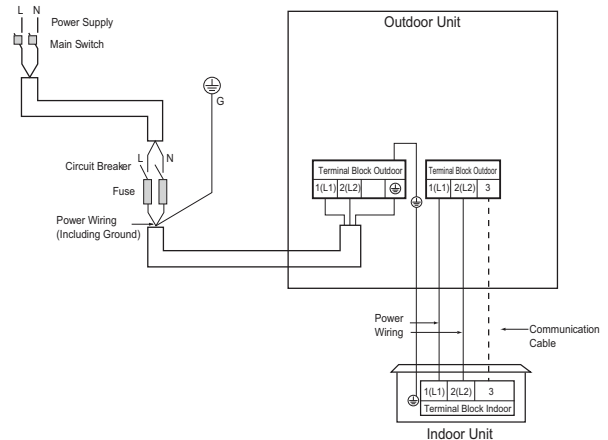

Power Supply / Power Wiring

- LG Single Zone Four-Way Cassette systems operate at 1Ø, 208-230V, 60Hz.
- Power wiring / power wiring gauge to the outdoor unit(s) must be solid or stranded, and must comply with all National Electrical Code (NEC), UL, and local electrical codes.
- The indoor unit is powered by the outdoor unit. See below and the next page for communication / connection (power) cable specifications from the outdoor unit to the indoor unit.
- Ground wire must be longer than the common power / communication wires.
- Connect the wiring firmly so the wires cannot be easily pulled out.
- Always match color codes of each wire and follow wiring diagram.
- ⚠ Do not install power wiring to the outdoor unit and the communication / connection (power) cable to the indoor unit in the same conduit. Use separate conduits.

⚠ WARNING

- Terminal screws will become loose during transport. Properly tighten the terminal connections during installation or risk electric shock, physical injury, or death.
- Loose wiring will cause unit to malfunction, overheat, and catch fire, resulting in severe injury or death.

⚠ NOTE

- Terminal screws will loosen during transport. Properly tighten the terminal connections during installation or risk equipment malfunction or property damage.
- Loose wiring will cause unit malfunction, the wires to burnout or the terminal to overheat and catch fire. There is a risk of equipment malfunction or property damage.

A voltage drop will cause the following problems:

- Magnetic switch vibration, fuse breaks, or disturbance to the normal function of an overload protection device.
- Compressor will not receive the proper starting current.

ELECTRICAL CONNECTIONS

Communication / Connection (Power) Cable Specifications from Outdoor Unit to Indoor Unit

- Communication / connection (power) cable from the single zone outdoor unit to the indoor unit must use a minimum of 14 AWG, four (4) conductor, stranded, shielded or unshielded (if shielded, it must be grounded to the chassis of the outdoor unit only), and must comply with applicable local and national codes.
- Use of 14 AWG, four (4) conductor, stranded, shielded or unshielded wire is allowed for lengths up to the published maximum pipe length, plus recommended slack at both ends.
- Insulation material as required by local code.
- Firmly attach the cable; provide slack but secure in a way to prevent external forces from being imparted on the terminal block.
- Wiring must be completed without splices.

Figure 30: Single Zone Outdoor Unit to Indoor Unit Wiring and Communications Cable Diagram.

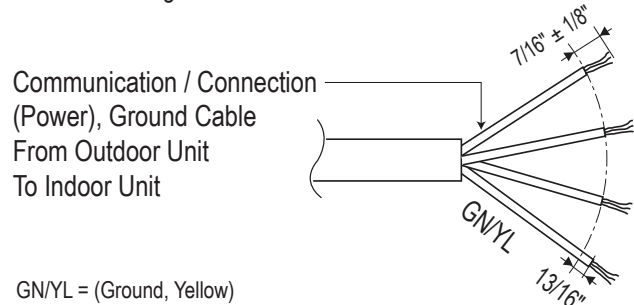

⚠ WARNING

All power wiring and communication cable installation must be performed by trained service providers working in accordance with local, state, and National Electrical Code (NEC) / UL / ETL federal regulations related to electrical equipment and wiring, and following the manufacturer product diagrams, requirements, and instructions in this manual. Failure to do so will lead to electric shock which can cause physical injury or death.

Note:

- Always verify the communication cable is connected to a communications terminal on the Single Zone unit. ⚡ Never apply line voltage power to the communication cable connection. If contact is made, the PCBs will be damaged.
- The shield of the communications cable connecting the outdoor unit to the indoor unit must be grounded only to the outdoor unit frame.
- Tie the shield of each cable segment together using a wire nut at the indoor unit. Maintain polarity throughout the communication network.
- Position the incoming power to the outdoor unit away from the power / communications cables from the outdoor unit to the indoor unit.
- ⚡ Never use a common multiple-core communications cable.

Figure 31: Single Zone Cassette Power / Communication System Diagram (Appearances May Vary Slightly).

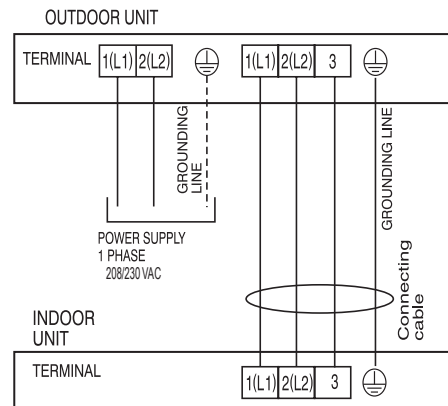

Note:

- Use a conduit for the communications cable / power wiring from the outdoor unit to the indoor units.
- Make sure the communications cable / power wiring from the outdoor unit to the indoor unit, and the power wiring to the outdoor unit are separate, otherwise, the outdoor unit operation will be affected by electrical noise and will malfunction or fail.

ELECTRICAL CONNECTIONS

Controller Options

Single Zone Four-Way Ceiling Cassette systems include a wireless handheld remote controller (For 9K, 12K, 18K Systems: Part No. AKB73757604, Model No. PQWRHQ0FDB; For 24, 36, 42K Systems: AKB75735404). Optional LG-supplied wired controllers are available. See “Functions, Controls, Options”, or contact an LG representative for more information.

Figure 32: AKB73757604 (PQWRHQ0FDB) Wireless Handheld Remote Controller.

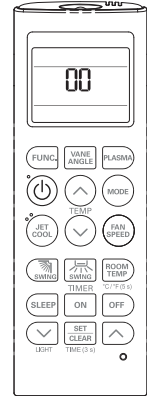

Wireless Handheld Remote Controller features:

- Display Panel: Displays operation conditions.
- On / Off Buttons: Turns system operation on and off.
- Mode Button: Selects the operation mode: Cooling, Heating, Auto, Dry (Dehumidification), or Fan.
- Temp Up / Down Buttons: Adjusts the desired room temperature in the different modes.
- Fan Speed Button: Sets desired fan speed.
- Reset: Initializes the handheld remote control settings.

Wired Controller Connections

Optional controllers (see “Functions, Controls, Options”, or contact an LG representative for more information) can connect to the Four-Way Ceiling Cassette indoor unit in one of two different ways.

1. LG Wired Remote Extension Cable with Molex plug (PZCWRC1; sold separately) that connects to the CN-REMO terminal on the indoor unit PCB.
2. Field-supplied controller cable that connects to the indoor unit terminal block (must be at least UL2547 or UL1007, and at least FT-6 rated if local electric and building codes require plenum cable usage). Communication cable from indoor unit to remote controller(s) is to be 22 AWG, 3-conductor, twisted, stranded, unshielded. Wiring must comply with all applicable local and national codes.

Note:

When using field-supplied controller cable, make sure to connect the yellow to yellow (communications wire), red to red (12V power wire), and black to black (ground wire) terminals from the remote controller to the indoor unit terminal blocks.

Figure 33: PZCWRC1 LG Wired Remote Extension Cable.

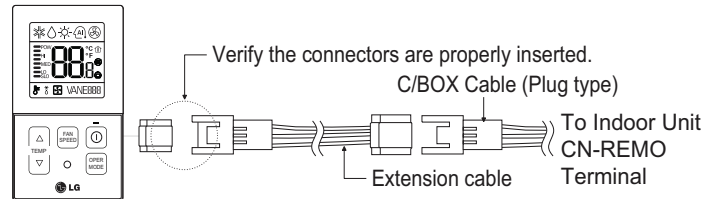

Figure 34: Wired Controller Connection (Example Only).

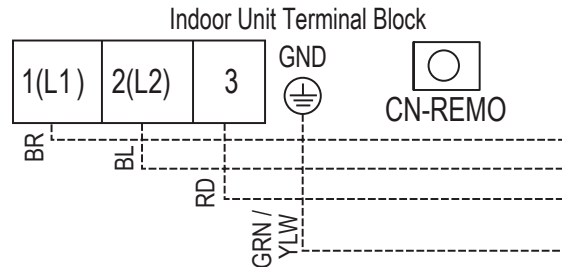
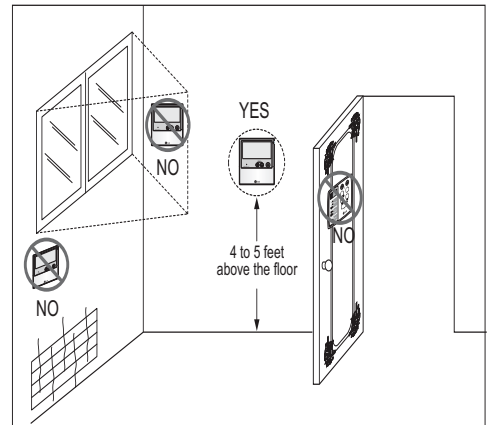

Figure 35: Proper Location for the Wired Controller.

Wired Controller Placement

Wired controllers include a sensor to detect room temperature. To maintain comfort levels in the conditioned space, the wired controller must be installed in a location away from direct sunlight, high humidity, and where it could be directly exposed to cold air. Controller must be installed four (4) to five (5) feet above the floor where its LED display can be read easily, in an area with good air circulation, and where it can detect an average room temperature.

- ⊘ Do not install the wired controller near or in:
 - Drafts or dead spots behind doors and in corners.
 - Hot or cold air from ducts.
 - Radiant heat from the sun or appliances.
 - Concealed pipes and chimneys.
 - An area where temperatures are uncontrolled, such as an outside wall.



Assigning the Thermistor for Temperature Detection

Each indoor unit includes a return air thermistor assigned to sense the temperature. If a wired controller is installed, there is a choice of sensing temperature with either the indoor unit return air thermistor or the thermistor in the wired controller. It is also an option to set both thermistors to sense temperature so that indoor unit bases its operation on the first thermistor to reach the designated temperature differential.

AIR VELOCITY AND TEMPERATURE DISTRIBUTION

Figure 36: LCN098HV4 Air Velocity and Temperature Distribution Charts.

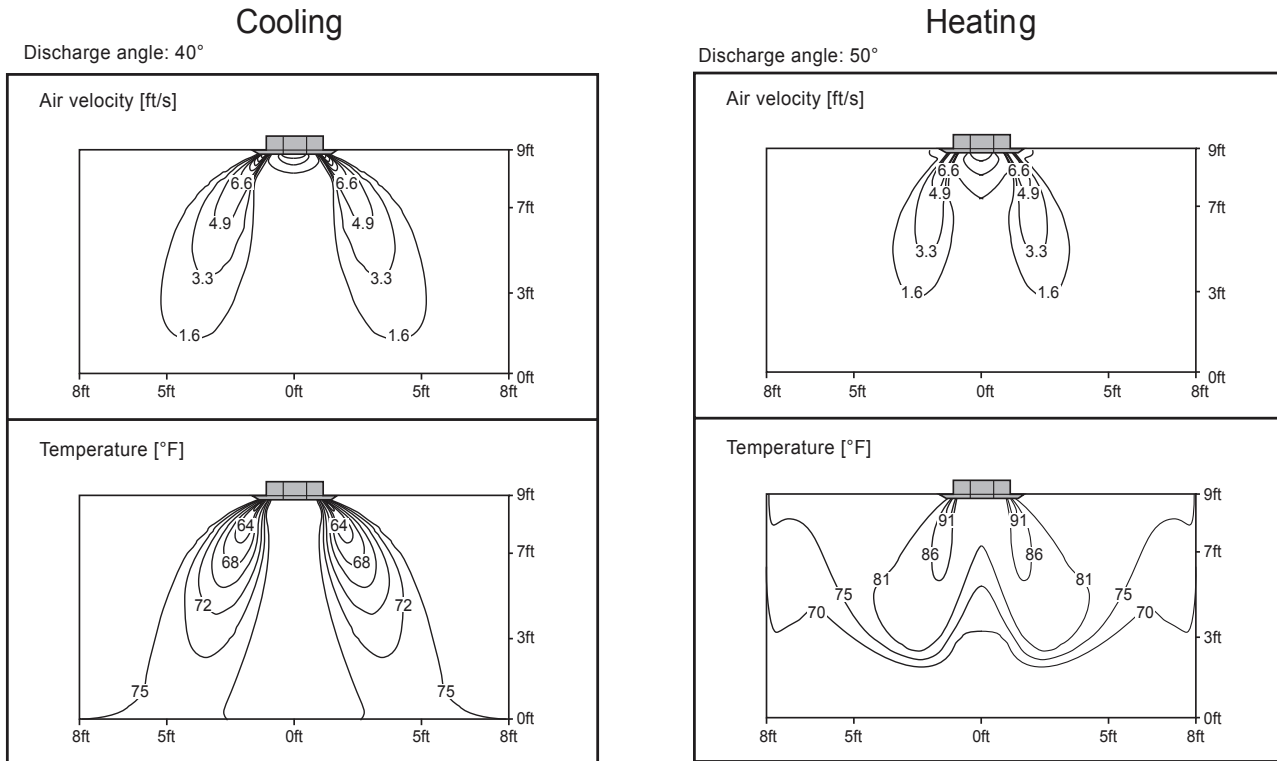
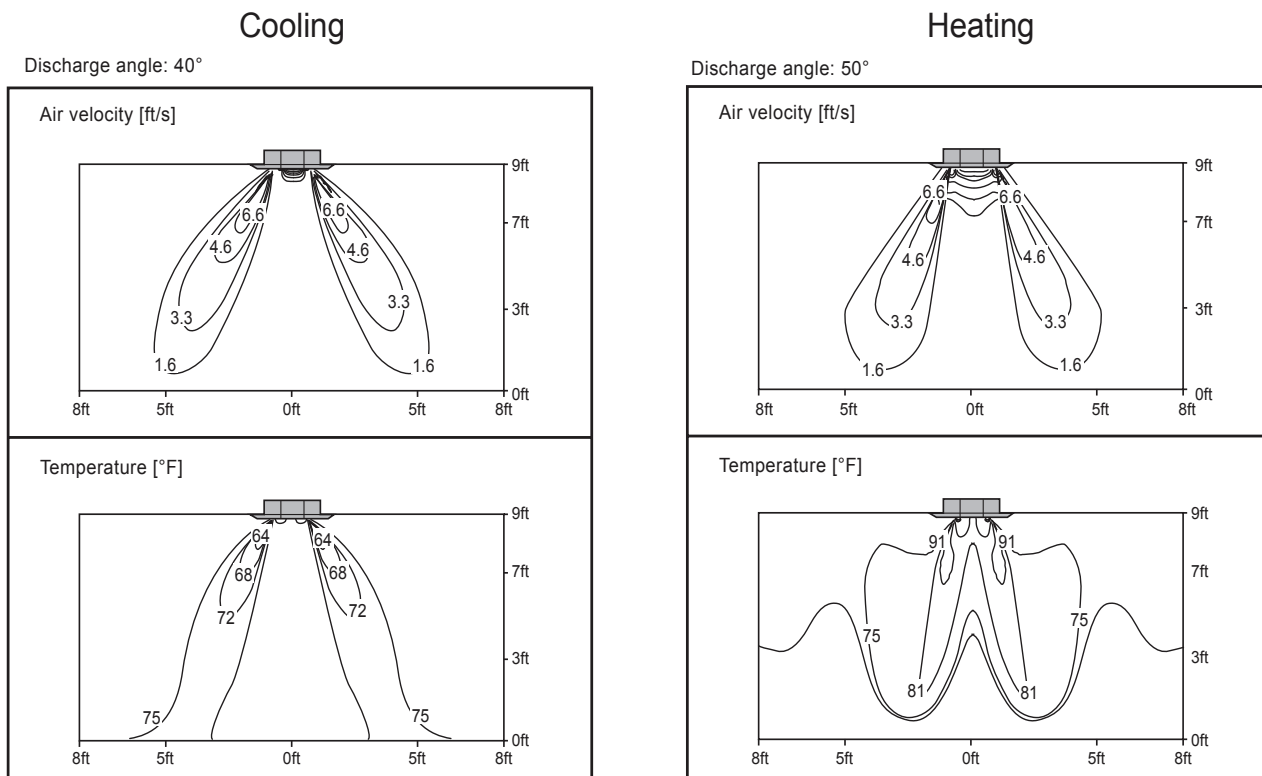

Figure 37: LCN128HV4 Air Velocity and Temperature Distribution Charts.



AIR VELOCITY AND TEMPERATURE DISTRIBUTION

Figure 38: LCN188HV4 Air Velocity and Temperature Distribution Charts.

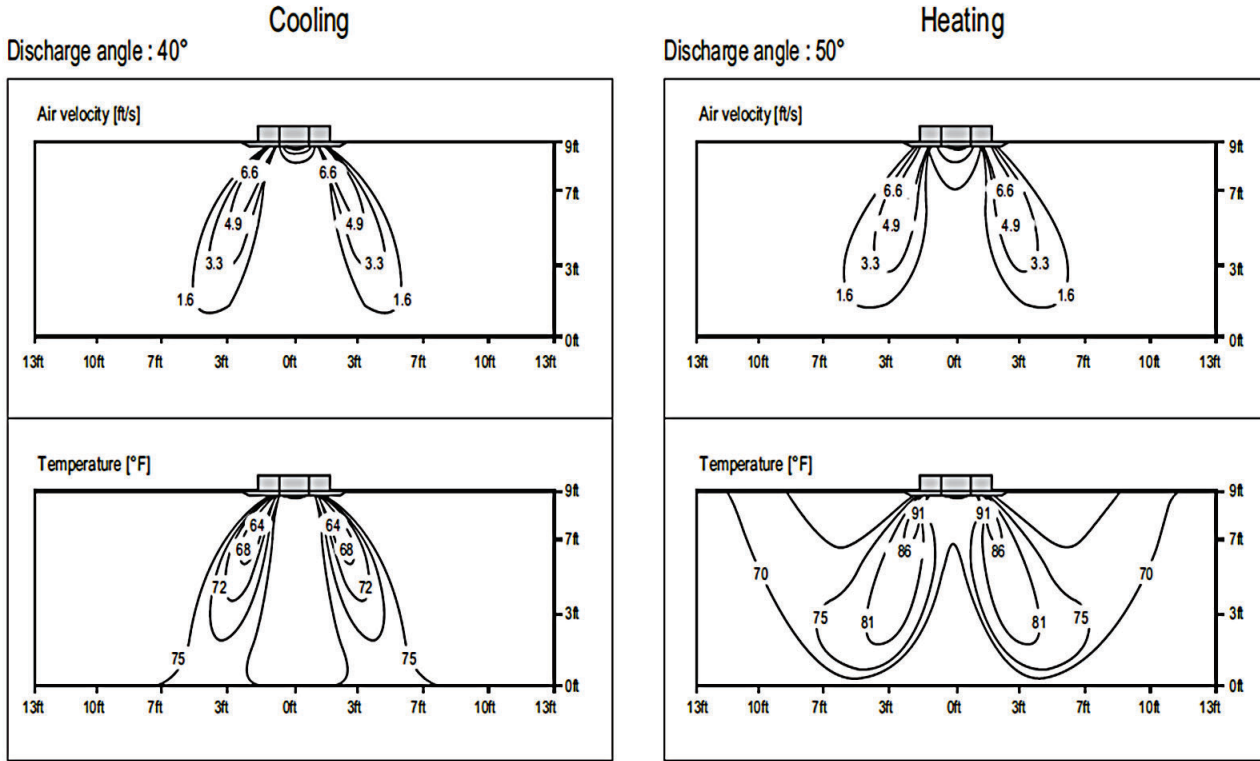
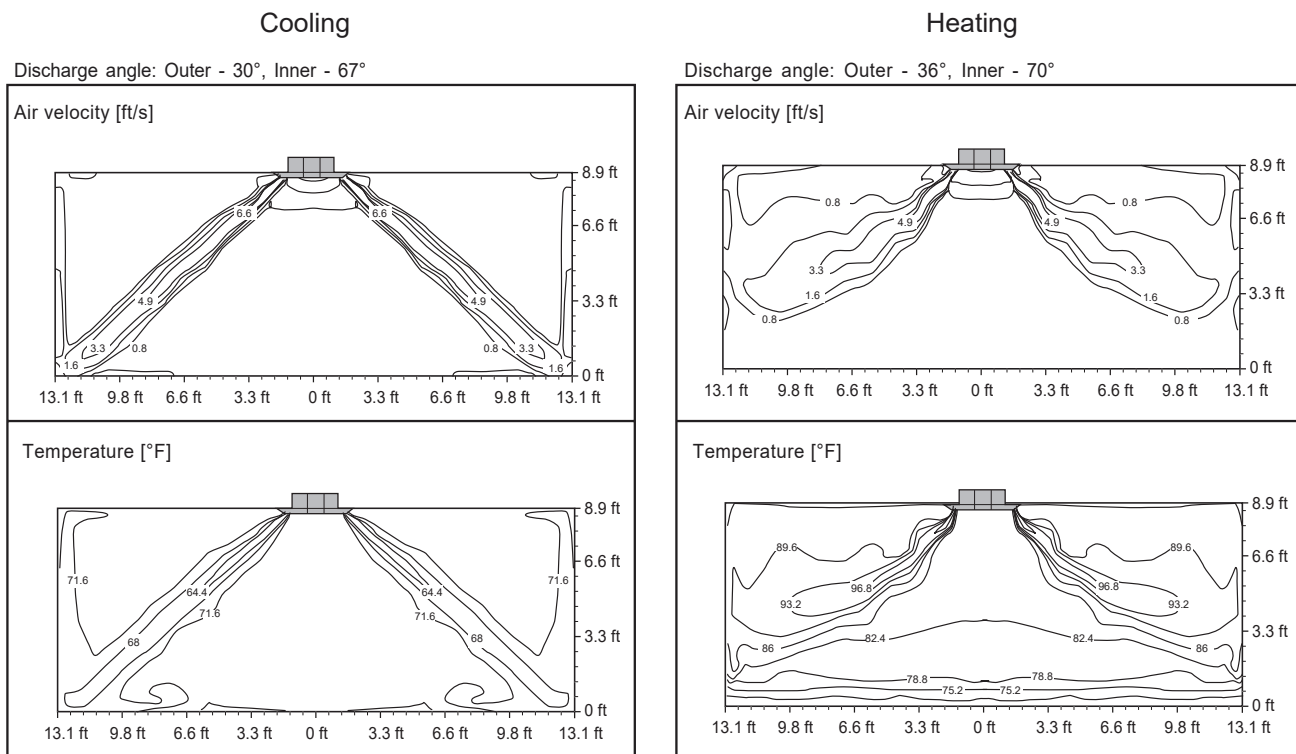

Figure 39: LCN249HV Air Velocity and Temperature Distribution Charts.



AIR VELOCITY AND TEMPERATURE DISTRIBUTION

Figure 40: LCN369HV Air Velocity and Temperature Distribution Charts.

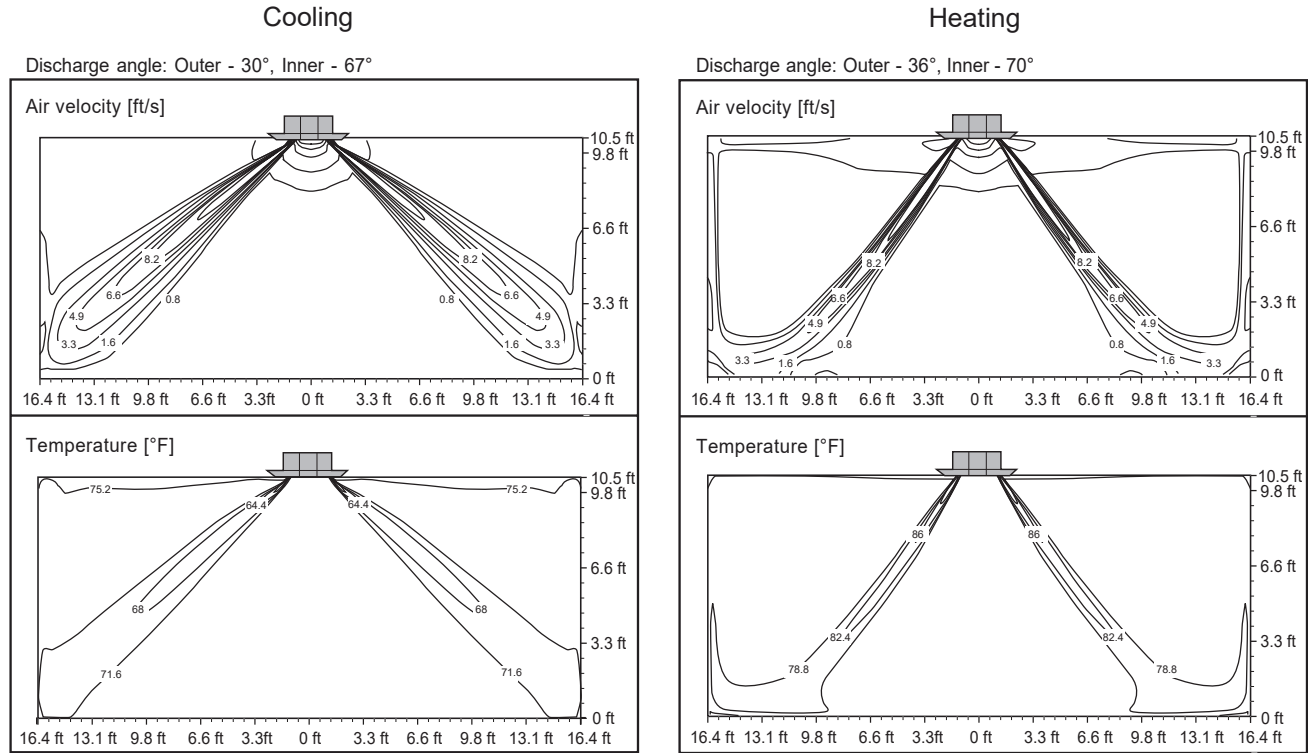
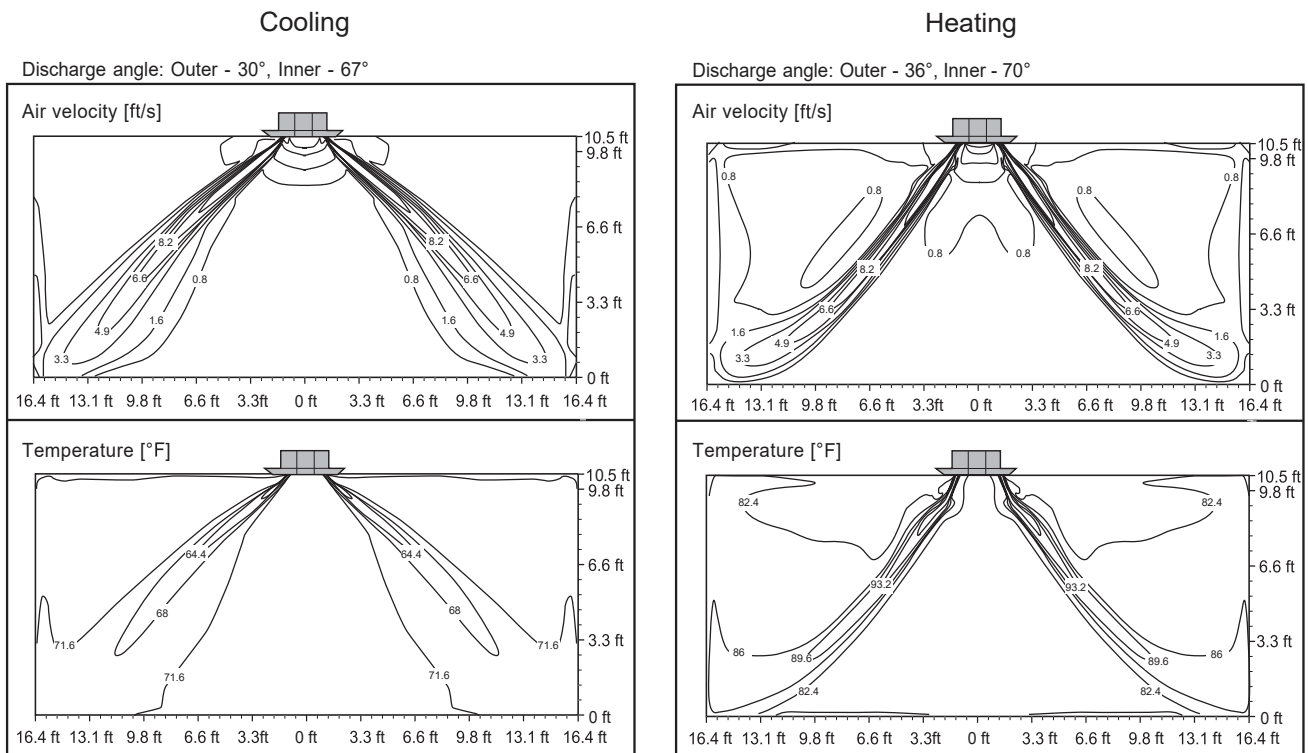

Figure 41: LCN429HV Air Velocity and Temperature Distribution Charts.



Product Data

ACCESSORIES

LG Monitoring View (LGMV) Diagnostic Software and Cable

LGMV software allows the service technician or commissioning agent to connect a computer USB port to the outdoor unit main printed circuit board (PCB) using an accessory cable without the need for a separate interface device. The main screen for LGMV allows user to view the following real time data on one screen:

- Actual inverter compressor speed
- Target inverter compressor speed
- Actual outdoor fan speed
- Target outdoor unit fan speed
- Actual superheat
- Target superheat
- Actual subcooler circuit superheat
- Target subcooler circuit superheat
- Main EEV position
- Subcooling EEV position
- Inverter compressor current transducer value
- Outdoor air temperature
- Actual high pressure/saturation temperature
- Actual low pressure/saturation temperature
- Suction temperature
- Inverter compressor discharge temperature
- Constant speed compressor discharge temperature
- temperature
- Front outdoor coil pipe temperature
- Back outdoor coil pipe temperature
- Liquid line pipe temperature
- Subcooler inlet temperature
- Subcooler outlet temperature
- Average indoor unit (IDU) pipe temperature
- Inverter compressor operation indicator light
- Four-way reversing valve operation indicator light
- Pressure graph showing actual low pressure and actual high pressure levels
- Error code display
- Operating mode indicator
- Target high pressure
- Target low pressure
- PCB (printed circuit board) version
- Software version
- Installer name
- Model no. of outdoor units
- Site name
- Total number of connected indoor units
- Communication indicator lights
- Indoor unit capacity
- Indoor unit operating mode
- Indoor unit fan speed
- Indoor unit EEV position
- Indoor unit room temperature
- Indoor unit inlet pipe temperature
- Indoor unit outlet pipe temperature
- Indoor unit error code



Figure 42: Sample Cycleview.

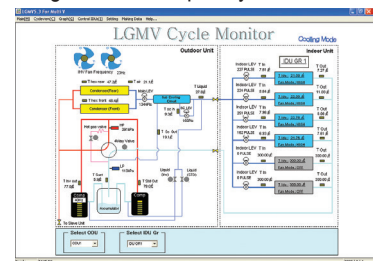

Additional screens can be accessed by tabs on the main screen:

1. Cycleview: Graphic of internal components including:
 - Compressors showing actual speeds
 - EEVs
 - Indoor Units
 - Liquid injection valves
 - Temperature and pressure sensors
 - Four-way reversing valve
 - Outdoor fans showing status and speeds
2. Graph: Full screen graph of actual high and low pressures and high and low pressure limits. A sliding bar enables user to go back in time and view data.
3. Control IDU: Enables user to turn on all IDU's default setpoints of 86°F in heat mode or 64°F in cool mode.
4. Setting: Converts metric values to imperial values.
5. Making Data: Recording of real time data to a separate file created to be stored on the user's computer.
6. Loading Data: Recorded data from a saved ".CSV" file can be loaded to create an LGMV session.
7. Electrical Data: The lower half of main screen is changed to show the following:
 - Inverter compressor
 - Amps
 - Volts
 - Power Hz
 - Inverter control board fan Hz
 - Constant compressor
 - Current transducer value
 - Phase

In lieu of connecting to the outdoor unit, user has the option to connect to the indoor unit with the use of a USB to RS-485 connector kit. When connected through the indoor unit, user will not be able to record data.

This software can be used to both commission new systems and troubleshoot existing systems. LGMV data can be recorded to a ".CSV" file and emailed to an LG representative to assist with diagnostic evaluations.

Recommended Minimum PC Configuration:

- CPU: Pentium® IV 1.6 GHz
- Operating System: Windows® NT/2000/XP/Vista
- Main Memory: 256 MB
- Hard Disk: 600 MB when operating
- Web Browser: Internet Explorer® 5.0

LGMV is available in different formats, including Mobile LGMV, which is a app for use on wireless devices. Contact your LG Sales Representative for more information.

Four-Way Ceiling-Cassette Accessories Overview

Table 22: Four-Way Ceiling-Cassette Accessories Overview.

Accessory	Model Number
24-13/32" x 24-13/32" (2' x 2') Four-Way Ceiling Cassette Panel — White (One Required) For Use with TR Frame for 2'x2' 9,000 Btu/h and 12,000 Btu/h Indoor Units; TQ Frame for 2'x2' 18,000 Btu/h Four-Way Ceiling Cassette Indoor Units	PT-QAGW0 / PT-QCHW0
Standard Panel — White (One Required) For Use with TP-B Frame for 3'x3' 24,000 Btu/h Indoor Units; TM-A Frame for 3'x3' 36,000 Btu/h and 42,000 Btu/h Indoor Units	PT-AAGW0
Premium Panel (Includes Panel PT-AFGW0 + Air Purification Kit PTAHMP0) For Use with TP-B Frame for 3'x3' 24,000 Btu/h Indoor Units; TM-A Frame for 3'x3' 36,000 Btu/h and 42,000 Btu/h Indoor Units	PT-AFGW0S
Air Purification Kit (Only Available with Premium Panel PTAFGW0S) For Use with TP-B Frame for 3'x3' 24,000 Btu/h Indoor Units; TM-A Frame for 3'x3' 36,000 Btu/h and 42,000 Btu/h Indoor Units	PTAHMP0
Cassette Decorative Cover For Use with TP-B Frame for 3'x3' 24,000 Btu/h Indoor Units; TM-A Frame for 3'x3' 36,000 Btu/h and 42,000 Btu/h Indoor Units	PTDCA
Ventilation Kit For Use with TP-B Frame for 3'x3' 24,000 Btu/h Indoor Units; TM-A Frame for 3'x3' 36,000 Btu/h and 42,000 Btu/h Indoor Units	PTVK410 + PTVK420
Ventilation Flange For Use with All Four-Way Ceiling Cassette Indoor Units	PTVK430
Low Ambient Wind Baffle For Use with 9 and 12k Capacities	ZLABGP01A
Low Ambient Wind Baffle For 18k and 24k Capacities (One [1] Required), 36k and 42k Capacities (Two [2] Required)	ZLABGP04A
Auto Elevation Kit For Use with TP-B Frame for 3'x3' 24,000 Btu/h Indoor Units; TM-A Frame for 3'x3' 36,000 Btu/h and 42,000 Btu/h Indoor Units	PTEGM0
120W Drain Pan Heater For Use with 9K and 12K Outdoor Units	PQSH1202
120W Drain Pan Heater For Use with 18k ~ 42k Outdoor Units	PQSH1200
PI-485 For Use with 18k ~ 42k Outdoor Units	PMNFP14A1
AHU Communication Kit For Use with All Four-Way Ceiling Cassette Indoor Units	PAHCMR000
Auxiliary Heater Kit1 For Use with All Four-Way Ceiling Cassette Indoor Units	PRARH1
Wi-Fi Module For Use with All Four-Way Ceiling Cassette Indoor Units	PWFMD200

PERFORMANCE DATA

Cooling Capacity Data on page 49

Heating Capacity Data on page 55

Maximum Cooling Capacity Data on page 58

Maximum Heating Capacity Data on page 61

Equipment Selection Procedure on page 64

PERFORMANCE DATA

Cooling Capacity LC098HV

Cooling Capacity Table for LC098HV (LCN098HV4 + LUU090HV)

Table 23: LCN098HV4 / LUU090HV Cooling Capacities.

Outdoor Air Temp. (°F DB)	Indoor Air Temp. °F DB / °F WB																	
	68 / 57			73 / 61			77 / 64			80 / 67			86 / 72			90 / 75		
	TC	SHC	PI	TC	SHC	PI	TC	SHC	PI	TC	SHC	PI	TC	SHC	PI	TC	SHC	PI
-4	8.85	6.84	0.39	9.40	7.23	0.40	9.95	7.00	0.42	10.34	7.15	0.42	11.05	7.21	0.43	11.60	7.34	0.44
0	8.84	6.88	0.39	9.39	7.27	0.41	9.94	7.04	0.42	10.34	7.19	0.43	11.04	7.25	0.44	11.59	7.39	0.45
5	8.84	6.94	0.40	9.38	7.33	0.42	9.93	7.10	0.43	10.33	7.25	0.44	11.03	7.31	0.44	11.58	7.45	0.45
10	8.83	7.00	0.41	9.38	7.39	0.42	9.93	7.16	0.44	10.32	7.31	0.44	11.02	7.37	0.45	11.57	7.51	0.46
15	8.82	7.05	0.41	9.37	7.45	0.43	9.92	7.21	0.44	10.31	7.37	0.45	11.01	7.43	0.46	11.56	7.57	0.47
20	8.82	7.11	0.42	9.36	7.51	0.43	9.91	7.27	0.45	10.31	7.42	0.46	11.01	7.49	0.46	11.55	7.63	0.47
25	8.81	7.16	0.42	9.36	7.57	0.44	9.90	7.33	0.46	10.30	7.48	0.46	11.00	7.54	0.47	11.54	7.69	0.48
30	8.80	7.22	0.43	9.35	7.63	0.45	9.90	7.38	0.46	10.29	7.54	0.47	10.99	7.60	0.48	11.54	7.75	0.49
35	8.80	7.27	0.44	9.34	7.68	0.45	9.89	7.44	0.47	10.28	7.60	0.47	10.98	7.66	0.48	11.53	7.81	0.49
40	8.79	7.33	0.44	9.33	7.74	0.46	9.88	7.50	0.48	10.27	7.65	0.48	10.97	7.72	0.49	11.52	7.86	0.50
45	8.78	7.38	0.45	9.33	7.80	0.47	9.87	7.55	0.48	10.27	7.71	0.49	10.96	7.78	0.50	11.51	7.92	0.51
50	8.78	7.44	0.45	9.32	7.86	0.47	9.87	7.61	0.49	10.26	7.77	0.49	10.96	7.83	0.50	11.50	7.98	0.51
55	8.77	7.49	0.46	9.31	7.91	0.48	9.86	7.66	0.49	10.25	7.82	0.50	10.95	7.89	0.51	11.49	8.04	0.52
60	8.76	7.55	0.47	9.31	7.97	0.48	9.85	7.72	0.50	10.24	7.88	0.51	10.94	7.95	0.52	11.48	8.10	0.53
65	8.76	7.60	0.47	9.30	8.03	0.49	9.84	7.77	0.51	10.24	7.94	0.51	10.93	8.00	0.52	11.47	8.16	0.53
70	8.75	7.65	0.48	9.29	8.09	0.50	9.84	7.83	0.51	10.23	7.99	0.52	10.92	8.06	0.53	11.47	8.21	0.54
75	8.54	7.53	0.50	9.08	7.96	0.52	9.62	7.72	0.54	10.01	7.89	0.55	10.71	7.96	0.56	11.25	8.12	0.57
80	8.33	7.40	0.53	8.87	7.84	0.55	9.41	7.61	0.57	9.80	7.78	0.58	10.49	7.86	0.59	11.03	8.03	0.60
85	8.12	7.27	0.56	8.66	7.71	0.58	9.20	7.49	0.60	9.59	7.66	0.60	10.28	7.76	0.62	10.82	7.92	0.63
90	7.91	7.13	0.58	8.45	7.57	0.60	8.99	7.37	0.62	9.37	7.55	0.63	10.06	7.65	0.64	10.60	7.82	0.66
95	7.68	7.05	0.61	8.22	7.50	0.63	8.75	7.31	0.65	9.00	7.38	0.66	9.83	7.61	0.67	10.36	7.79	0.69
100	7.50	6.86	0.63	8.03	7.31	0.66	8.57	7.14	0.68	8.88	7.27	0.69	9.64	7.44	0.70	10.17	7.63	0.72
105	7.31	6.68	0.66	7.84	7.13	0.68	8.38	6.96	0.71	8.77	7.15	0.72	9.45	7.28	0.73	9.99	7.47	0.74
110	7.12	6.45	0.68	7.66	6.89	0.71	8.19	6.75	0.74	8.58	6.94	0.74	9.26	7.07	0.76	9.80	7.26	0.77
115	6.94	6.25	0.71	7.47	6.70	0.74	8.01	6.57	0.76	8.39	6.76	0.77	9.08	6.90	0.79	9.61	7.10	0.80
118	6.82	6.21	0.73	7.36	6.66	0.75	7.89	6.54	0.78	8.28	6.73	0.79	8.96	6.88	0.80	9.50	7.08	0.82
122	6.79	6.19	0.75	7.32	6.65	0.77	7.86	6.52	0.80	8.24	6.72	0.81	8.93	6.87	0.83	9.46	7.07	0.84

DB: Dry Bulb Temperature (°F) WB: Wet Bulb Temperature (°F) TC: Total Capacity (kBtu/h)

SHC: Sensible Capacity (kBtu/h) PI: Power Input (kW) (includes compressor, indoor fan motor and outdoor fan motor)

1. All capacities are net, evaporator fan motor heat is deducted.
2. Cooling range can be extended from 0°F down to -4°F using the Low Ambient Wind Baffle Kit (sold separately).
3. Grey shading indicates reference data. When operating at this temperature, these values can be different if the system is not running consistently.

4. Direct interpolation is permissible. ⚠ Do not extrapolate.

Capacity as rated: 0 ft. above sea level with 24.6 ft. of refrigerant piping. 0 ft. level difference between outdoor and indoor units.

Cooling capacity rating obtained with air entering the indoor unit at 80°F dry bulb (DB) and 67°F wet bulb (WB), and outdoor ambient conditions of 95°F dry bulb (DB) and 75°F wet bulb (WB).

PERFORMANCE DATA

Cooling Capacity LC128HV

Cooling Capacity Table for LC128HV (LCN128HV4 + LUU120HV)

Table 24: LCN128HV4 / LUU120HV Cooling Capacities.

Outdoor Air Temp. (°F DB)	Indoor Air Temp. °F DB / °F WB																	
	68 / 57			73 / 61			77 / 64			80 / 67			86 / 72			90 / 75		
	TC	SHC	PI	TC	SHC	PI	TC	SHC	PI	TC	SHC	PI	TC	SHC	PI	TC	SHC	PI
-4	10.91	7.83	0.52	11.59	8.27	0.54	12.27	8.00	0.56	12.76	8.17	0.57	13.62	8.24	0.58	14.30	8.40	0.59
0	10.91	7.87	0.53	11.58	8.32	0.55	12.26	8.05	0.57	12.75	8.22	0.57	13.62	8.29	0.58	14.29	8.45	0.59
5	10.90	7.94	0.53	11.57	8.38	0.55	12.25	8.12	0.57	12.74	8.29	0.58	13.61	8.36	0.59	14.28	8.52	0.60
10	10.89	8.00	0.54	11.57	8.45	0.56	12.24	8.18	0.58	12.73	8.35	0.59	13.59	8.42	0.60	14.27	8.58	0.61
15	10.88	8.06	0.55	11.56	8.52	0.57	12.23	8.25	0.59	12.72	8.42	0.60	13.58	8.49	0.61	14.26	8.65	0.62
20	10.87	8.13	0.56	11.55	8.58	0.58	12.22	8.31	0.60	12.71	8.49	0.61	13.57	8.56	0.62	14.25	8.72	0.63
25	10.86	8.19	0.57	11.54	8.65	0.59	12.21	8.38	0.61	12.70	8.55	0.62	13.56	8.62	0.63	14.24	8.79	0.64
30	10.86	8.25	0.57	11.53	8.72	0.60	12.20	8.44	0.62	12.69	8.62	0.62	13.55	8.69	0.64	14.23	8.85	0.65
35	10.85	8.31	0.58	11.52	8.78	0.60	12.20	8.50	0.63	12.68	8.68	0.63	13.54	8.76	0.64	14.22	8.92	0.66
40	10.84	8.38	0.59	11.51	8.85	0.61	12.19	8.57	0.63	12.67	8.75	0.64	13.53	8.82	0.65	14.21	8.99	0.67
45	10.83	8.44	0.60	11.50	8.91	0.62	12.18	8.63	0.64	12.66	8.81	0.65	13.52	8.89	0.66	14.19	9.06	0.68
50	10.82	8.50	0.61	11.50	8.98	0.63	12.17	8.70	0.65	12.65	8.88	0.66	13.51	8.95	0.67	14.18	9.12	0.68
55	10.81	8.56	0.61	11.49	9.05	0.64	12.16	8.76	0.66	12.64	8.94	0.67	13.50	9.02	0.68	14.17	9.19	0.69
60	10.81	8.63	0.62	11.48	9.11	0.64	12.15	8.82	0.67	12.63	9.01	0.68	13.49	9.08	0.69	14.16	9.26	0.70
65	10.80	8.69	0.63	11.47	9.18	0.65	12.14	8.89	0.68	12.62	9.07	0.68	13.48	9.15	0.70	14.15	9.32	0.71
70	10.79	8.75	0.64	11.46	9.24	0.66	12.13	8.95	0.69	12.61	9.14	0.69	13.47	9.22	0.71	14.14	9.39	0.72
75	10.53	8.61	0.67	11.20	9.10	0.70	11.87	8.82	0.72	12.35	9.02	0.73	13.20	9.10	0.74	13.87	9.28	0.76
80	10.27	8.46	0.71	10.94	8.96	0.73	11.60	8.70	0.76	12.09	8.89	0.77	12.94	8.99	0.78	13.60	9.17	0.80
85	10.01	8.30	0.74	10.68	8.81	0.77	11.34	8.56	0.80	11.82	8.76	0.81	12.67	8.87	0.82	13.34	9.06	0.84
90	9.76	8.15	0.78	10.42	8.65	0.80	11.08	8.42	0.83	11.56	8.63	0.84	12.41	8.74	0.86	13.07	8.94	0.88
95	9.48	8.06	0.81	10.14	8.58	0.84	10.80	8.36	0.87	11.10	8.44	0.88	12.12	8.70	0.90	12.78	8.90	0.91
100	9.25	7.85	0.84	9.91	8.36	0.87	10.57	8.16	0.91	10.96	8.31	0.92	11.89	8.51	0.93	12.55	8.72	0.95
105	9.02	7.63	0.88	9.68	8.14	0.91	10.34	7.96	0.94	10.81	8.18	0.95	11.66	8.32	0.97	12.32	8.54	0.99
110	8.78	7.37	0.91	9.44	7.88	0.95	10.10	7.71	0.98	10.58	7.93	0.99	11.43	8.09	1.01	12.09	8.30	1.03
115	8.55	7.15	0.95	9.21	7.66	0.98	9.87	7.51	1.02	10.35	7.73	1.03	11.19	7.89	1.05	11.85	8.11	1.07
118	8.42	7.10	0.97	9.08	7.61	1.00	9.74	7.47	1.04	10.21	7.69	1.05	11.06	7.87	1.07	11.72	8.09	1.09
122	8.37	7.08	1.00	9.03	7.60	1.03	9.69	7.46	1.07	10.17	7.68	1.08	11.01	7.86	1.10	11.67	8.08	1.12

DB: Dry Bulb Temperature (°F) WB: Wet Bulb Temperature (°F) TC: Total Capacity (kBtu/h)

SHC: Sensible Capacity (kBtu/h) PI: Power Input (kW) (includes compressor, indoor fan motor and outdoor fan motor)

- All capacities are net, evaporator fan motor heat is deducted.
- Cooling range can be extended from 0°F down to -4°F using the Low Ambient Wind Baffle Kit (sold separately).
- Grey shading indicates reference data. When operating at this temperature, these values can be different if the system is not running consistently.

4. Direct interpolation is permissible. ⚠ Do not extrapolate.

Capacity as rated: 0 ft. above sea level with 24.6 ft. of refrigerant piping. 0 ft. level difference between outdoor and indoor units.

Cooling capacity rating obtained with air entering the indoor unit at 80°F dry bulb (DB) and 67°F wet bulb (WB), and outdoor ambient conditions of 95°F dry bulb (DB) and 75°F wet bulb (WB).

PERFORMANCE DATA

Cooling Capacity

LC188HV

Cooling Capacity Table for LC188HV (LCN188HV4 + LUU180HV)

Table 25: LCN188HV4 / LUU180HV Cooling Capacities.

Outdoor Air Temp. (°F DB)	Indoor Air Temp. °F DB / °F WB																	
	68 / 57			73 / 61			77 / 64			80 / 67			86 / 72			90 / 75		
	TC	SHC	PI	TC	SHC	PI	TC	SHC	PI	TC	SHC	PI	TC	SHC	PI	TC	SHC	PI
-4	17.70	11.95	0.85	18.80	12.62	0.88	19.89	12.22	0.92	20.69	12.48	0.93	22.09	12.59	0.94	23.19	12.82	0.96
0	17.69	12.02	0.86	18.79	12.70	0.89	19.88	12.29	0.93	20.68	12.55	0.94	22.08	12.66	0.95	23.18	12.90	0.97
5	17.67	12.12	0.88	18.77	12.81	0.91	19.87	12.40	0.94	20.66	12.66	0.95	22.06	12.77	0.97	23.16	13.01	0.99
10	17.66	12.22	0.89	18.76	12.91	0.92	19.85	12.50	0.95	20.64	12.76	0.97	22.05	12.87	0.98	23.14	13.11	1.00
15	17.65	12.32	0.90	18.74	13.01	0.93	19.84	12.60	0.97	20.63	12.86	0.98	22.03	12.97	1.00	23.12	13.22	1.02
20	17.63	12.41	0.91	18.73	13.11	0.95	19.82	12.70	0.98	20.61	12.96	0.99	22.01	13.07	1.01	23.11	13.32	1.03
25	17.62	12.51	0.93	18.71	13.22	0.96	19.81	12.80	1.00	20.60	13.06	1.01	22.00	13.18	1.03	23.09	13.42	1.05
30	17.60	12.61	0.94	18.70	13.32	0.97	19.79	12.89	1.01	20.58	13.17	1.02	21.98	13.28	1.04	23.07	13.53	1.06
35	17.59	12.70	0.95	18.68	13.42	0.99	19.78	12.99	1.02	20.57	13.27	1.04	21.96	13.38	1.05	23.05	13.63	1.08
40	17.58	12.80	0.97	18.67	13.52	1.00	19.76	13.09	1.04	20.55	13.37	1.05	21.94	13.48	1.07	23.04	13.73	1.09
45	17.56	12.89	0.98	18.66	13.62	1.01	19.75	13.19	1.05	20.53	13.46	1.06	21.93	13.58	1.08	23.02	13.84	1.11
50	17.55	12.99	0.99	18.64	13.72	1.03	19.73	13.28	1.07	20.52	13.56	1.08	21.91	13.68	1.10	23.00	13.94	1.12
55	17.54	13.08	1.00	18.63	13.82	1.04	19.72	13.38	1.08	20.50	13.66	1.09	21.89	13.78	1.11	22.98	14.04	1.13
60	17.52	13.18	1.02	18.61	13.92	1.05	19.70	13.48	1.09	20.49	13.76	1.11	21.88	13.88	1.13	22.97	14.14	1.15
65	17.51	13.27	1.03	18.60	14.02	1.07	19.69	13.58	1.11	20.47	13.86	1.12	21.86	13.98	1.14	22.95	14.24	1.16
70	17.50	13.37	1.04	18.58	14.12	1.08	19.67	13.67	1.12	20.46	13.96	1.13	21.84	14.08	1.16	22.93	14.35	1.18
75	17.08	13.15	1.10	18.16	13.91	1.14	19.24	13.48	1.18	20.03	13.78	1.20	21.41	13.91	1.22	22.50	14.18	1.24
80	16.66	12.92	1.16	17.74	13.69	1.20	18.82	13.28	1.24	19.60	13.58	1.26	20.98	13.73	1.28	22.06	14.02	1.31
85	16.24	12.69	1.21	17.32	13.46	1.26	18.40	13.08	1.30	19.17	13.38	1.32	20.55	13.55	1.34	21.63	13.84	1.37
90	15.82	12.45	1.27	16.90	13.22	1.32	17.97	12.87	1.36	18.75	13.18	1.38	20.12	13.36	1.40	21.20	13.66	1.43
95	15.37	12.32	1.33	16.44	13.10	1.37	17.51	12.77	1.42	18.00	12.89	1.44	19.65	13.29	1.47	20.72	13.60	1.50
100	14.99	11.99	1.38	16.06	12.77	1.43	17.13	12.46	1.48	17.77	12.69	1.50	19.28	13.00	1.53	20.35	13.32	1.56
105	14.62	11.66	1.44	15.69	12.44	1.49	16.76	12.16	1.54	17.53	12.49	1.56	18.90	12.71	1.59	19.97	13.04	1.62
110	14.24	11.26	1.49	15.32	12.04	1.55	16.39	11.78	1.61	17.16	12.12	1.62	18.53	12.35	1.65	19.60	12.68	1.69
115	13.87	10.92	1.55	14.94	11.70	1.61	16.01	11.47	1.67	16.79	11.81	1.68	18.15	12.06	1.72	19.22	12.39	1.75
118	13.65	10.84	1.58	14.72	11.63	1.64	15.79	11.41	1.70	16.56	11.75	1.72	17.93	12.02	1.75	19.00	12.36	1.79
122	13.57	10.82	1.63	14.64	11.61	1.69	15.71	11.39	1.75	16.49	11.74	1.77	17.85	12.00	1.80	18.92	12.35	1.84

DB: Dry Bulb Temperature (°F) WB: Wet Bulb Temperature (°F) TC: Total Capacity (kBtu/h)
 SHC: Sensible Capacity (kBtu/h) PI: Power Input (kW) (includes compressor, indoor fan motor and outdoor fan motor)

1. All capacities are net, evaporator fan motor heat is deducted.
2. Cooling range can be extended from 5°F down to -4°F using the Low Ambient Wind Baffle Kit (sold separately).
3. Grey shading indicates reference data. When operating at this temperature, these values can be different if the system is not running consistently.

4. Direct interpolation is permissible. ☹ Do not extrapolate.
 Capacity as rated: 0 ft. above sea level with 24.6 ft. of refrigerant piping, 0 ft. level difference between outdoor and indoor units.
 Cooling capacity rating obtained with air entering the indoor unit at 80°F dry bulb (DB) and 67°F wet bulb (WB), and outdoor ambient conditions of 95°F dry bulb (DB) and 75°F wet bulb (WB).

Performance Data



PERFORMANCE DATA

Cooling Capacity

LC249HV

Cooling Capacity Table for LC249HV (LCN249HV + LUU240HV)

Table 26: LCN249HV / LUU240HV Cooling Capacities.

Outdoor Air Temp. (°F DB)	Indoor Air Temp. °F DB / °F WB																	
	68 / 57			73 / 61			77 / 64			80 / 67			86 / 72			90 / 75		
	TC	SHC	PI	TC	SHC	PI	TC	SHC	PI	TC	SHC	PI	TC	SHC	PI	TC	SHC	PI
-4	22.61	18.08	1.16	24.02	19.10	1.20	25.42	18.49	1.25	26.44	18.88	1.26	28.23	19.04	1.28	29.63	19.40	1.31
-0.4	22.60	18.19	1.17	24.00	19.21	1.22	25.41	18.60	1.26	26.42	18.99	1.27	28.21	19.15	1.30	29.62	19.52	1.32
5	22.58	18.34	1.19	23.98	19.38	1.23	25.39	18.76	1.28	26.40	19.16	1.29	28.19	19.32	1.32	29.59	19.69	1.35
10	22.56	18.49	1.21	23.97	19.53	1.25	25.37	18.91	1.30	26.38	19.31	1.31	28.17	19.47	1.34	29.57	19.84	1.37
15	22.55	18.64	1.23	23.95	19.69	1.27	25.35	19.06	1.32	26.36	19.46	1.33	28.15	19.63	1.36	29.55	20.00	1.39
20	22.53	18.78	1.24	23.93	19.84	1.29	25.33	19.21	1.34	26.34	19.62	1.35	28.13	19.78	1.38	29.53	20.16	1.41
25	22.51	18.93	1.26	23.91	19.99	1.31	25.31	19.36	1.36	26.32	19.77	1.37	28.10	19.93	1.40	29.50	20.31	1.43
30	22.50	19.07	1.28	23.89	20.15	1.33	25.29	19.51	1.37	26.30	19.92	1.39	28.08	20.09	1.42	29.48	20.47	1.44
35	22.48	19.22	1.30	23.87	20.30	1.34	25.27	19.66	1.39	26.28	20.07	1.41	28.06	20.24	1.44	29.46	20.62	1.46
40	22.46	19.36	1.31	23.86	20.45	1.36	25.25	19.81	1.41	26.26	20.22	1.43	28.04	20.39	1.46	29.44	20.78	1.48
45	22.44	19.51	1.33	23.84	20.61	1.38	25.23	19.95	1.43	26.24	20.37	1.45	28.02	20.54	1.47	29.41	20.93	1.50
50	22.43	19.65	1.35	23.82	20.76	1.40	25.21	20.10	1.45	26.22	20.52	1.47	28.00	20.70	1.49	29.39	21.09	1.52
55	22.41	19.80	1.37	23.80	20.91	1.42	25.19	20.25	1.47	26.20	20.67	1.49	27.98	20.85	1.51	29.37	21.24	1.54
60	22.39	19.94	1.39	23.78	21.06	1.44	25.17	20.39	1.49	26.18	20.82	1.51	27.95	21.00	1.53	29.35	21.40	1.56
65	22.37	20.08	1.40	23.76	21.21	1.45	25.15	20.54	1.51	26.16	20.97	1.52	27.93	21.15	1.55	29.32	21.55	1.58
70	22.36	20.23	1.42	23.75	21.37	1.47	25.13	20.69	1.53	26.14	21.12	1.54	27.91	21.30	1.57	29.30	21.70	1.60
75	21.82	19.89	1.50	23.20	21.04	1.55	24.59	20.40	1.61	25.59	20.84	1.63	27.36	21.04	1.66	28.75	21.46	1.69
80	21.28	19.55	1.57	22.66	20.71	1.63	24.04	20.10	1.69	25.04	20.55	1.71	26.81	20.78	1.74	28.19	21.21	1.78
85	20.75	19.20	1.65	22.13	20.36	1.71	23.50	19.79	1.77	24.50	20.25	1.79	26.26	20.50	1.83	27.64	20.94	1.86
90	20.22	18.83	1.73	21.59	20.01	1.79	22.96	19.47	1.86	23.96	19.94	1.88	25.71	20.21	1.91	27.09	20.67	1.95
95	19.64	18.64	1.80	21.00	19.83	1.87	22.37	19.32	1.94	23.00	19.50	1.96	25.11	20.10	2.00	26.48	20.58	2.04
100	19.16	18.14	1.88	20.53	19.33	1.95	21.89	18.86	2.02	22.70	19.20	2.04	24.63	19.67	2.08	26.00	20.15	2.12
105	18.68	17.64	1.96	20.05	18.83	2.03	21.42	18.40	2.10	22.40	18.90	2.13	24.15	19.24	2.17	25.52	19.73	2.21
110	18.20	17.03	2.03	19.57	18.22	2.11	20.94	17.83	2.18	21.93	18.33	2.21	23.67	18.69	2.25	25.04	19.19	2.30
115	17.72	16.53	2.11	19.09	17.70	2.19	20.46	17.36	2.27	21.45	17.86	2.29	23.20	18.24	2.34	24.56	18.75	2.38
118	17.44	16.41	2.16	18.80	17.60	2.23	20.17	17.27	2.32	21.16	17.79	2.34	22.91	18.18	2.39	24.28	18.70	2.43
122	17.34	16.36	2.22	18.71	17.56	2.30	20.08	17.24	2.38	21.07	17.76	2.41	22.81	18.16	2.45	24.18	18.69	2.50

DB: Dry Bulb Temperature (°F) WB: Wet Bulb Temperature (°F) TC: Total Capacity (kBtu/h)
 SHC: Sensible Capacity (kBtu/h) PI: Power Input (kW) (includes compressor, indoor fan motor and outdoor fan motor)

- All capacities are net, evaporator fan motor heat is deducted.
- Cooling range can be extended from 5°F down to -4°F using the Low Ambient Wind Baffle Kit (sold separately).
- Grey shading indicates reference data. When operating at this temperature, these values can be different if the system is not running consistently.

4. Direct interpolation is permissible. ⚠ Do not extrapolate.

Capacity as rated: 0 ft. above sea level with 24.6 ft. of refrigerant piping. 0 ft. level difference between outdoor and indoor units.

Cooling capacity rating obtained with air entering the indoor unit at 80°F dry bulb (DB) and 67°F wet bulb (WB), and outdoor ambient conditions of 95°F dry bulb (DB) and 75°F wet bulb (WB).

PERFORMANCE DATA

Cooling Capacity LC369HV

Cooling Capacity Table for LC369HV (LCN369HV + LUU360HV)

Table 27: LCN369HV / LUU360HV Cooling Capacities.

Outdoor Air Temp. (°F DB)	Indoor Air Temp. °F DB / °F WB																	
	68 / 57			73 / 61			77 / 64			80 / 67			86 / 72			90 / 75		
	TC	SHC	PI	TC	SHC	PI	TC	SHC	PI	TC	SHC	PI	TC	SHC	PI	TC	SHC	PI
-4	35.39	26.04	1.70	37.59	27.50	1.77	39.79	26.63	1.83	41.38	27.19	1.85	44.19	27.42	1.89	46.38	27.94	1.92
-0.4	35.37	26.19	1.72	37.57	27.66	1.79	39.77	26.79	1.85	41.35	27.35	1.87	44.16	27.58	1.91	46.36	28.10	1.95
5	35.34	26.42	1.75	37.54	27.91	1.81	39.73	27.02	1.88	41.32	27.59	1.90	44.12	27.82	1.94	46.32	28.35	1.98
10	35.32	26.63	1.78	37.51	28.13	1.84	39.70	27.24	1.91	41.29	27.81	1.93	44.09	28.04	1.97	46.28	28.57	2.01
15	35.29	26.84	1.80	37.48	28.35	1.87	39.67	27.45	1.94	41.26	28.03	1.96	44.06	28.26	2.00	46.25	28.80	2.04
20	35.26	27.05	1.83	37.45	28.57	1.89	39.64	27.66	1.96	41.23	28.25	1.99	44.02	28.49	2.02	46.21	29.02	2.06
25	35.24	27.26	1.85	37.43	28.79	1.92	39.61	27.88	1.99	41.19	28.47	2.01	43.99	28.71	2.05	46.18	29.25	2.09
30	35.21	27.47	1.88	37.40	29.01	1.95	39.58	28.09	2.02	41.16	28.68	2.04	43.96	28.93	2.08	46.14	29.47	2.12
35	35.18	27.67	1.91	37.37	29.23	1.98	39.55	28.31	2.05	41.13	28.90	2.07	43.92	29.15	2.11	46.11	29.70	2.15
40	35.16	27.88	1.93	37.34	29.45	2.00	39.52	28.52	2.08	41.10	29.12	2.10	43.89	29.37	2.14	46.07	29.92	2.18
45	35.13	28.09	1.96	37.31	29.67	2.03	39.49	28.73	2.10	41.07	29.34	2.13	43.86	29.58	2.17	46.04	30.14	2.21
50	35.10	28.30	1.98	37.28	29.89	2.06	39.46	28.94	2.13	41.04	29.55	2.16	43.82	29.80	2.20	46.00	30.37	2.24
55	35.08	28.51	2.01	37.25	30.11	2.08	39.43	29.16	2.16	41.01	29.77	2.18	43.79	30.02	2.22	45.97	30.59	2.27
60	35.05	28.71	2.04	37.23	30.33	2.11	39.40	29.37	2.19	40.97	29.99	2.21	43.76	30.24	2.25	45.93	30.81	2.30
65	35.02	28.92	2.06	37.20	30.55	2.14	39.37	29.58	2.21	40.94	30.20	2.24	43.72	30.46	2.28	45.90	31.03	2.33
70	34.99	29.13	2.09	37.17	30.77	2.16	39.34	29.79	2.24	40.91	30.42	2.27	43.69	30.67	2.31	45.86	31.26	2.36
75	34.15	28.65	2.20	36.32	30.30	2.28	38.49	29.37	2.36	40.05	30.01	2.39	42.82	30.30	2.44	44.99	30.90	2.48
80	33.31	28.16	2.31	35.47	29.82	2.40	37.64	28.94	2.48	39.20	29.60	2.51	41.96	29.92	2.56	44.12	30.54	2.61
85	32.48	27.64	2.42	34.63	29.32	2.51	36.79	28.49	2.61	38.35	29.16	2.64	41.10	29.52	2.68	43.26	30.15	2.74
90	31.64	27.12	2.54	33.79	28.81	2.63	35.94	28.03	2.73	37.50	28.71	2.76	40.25	29.10	2.81	42.40	29.76	2.87
95	30.74	26.84	2.65	32.88	28.55	2.75	35.02	27.82	2.85	36.00	28.08	2.88	39.30	28.95	2.93	41.44	29.63	2.99
100	29.99	26.12	2.76	32.13	27.83	2.86	34.27	27.15	2.97	35.53	27.65	3.00	38.55	28.32	3.06	40.69	29.02	3.12
105	29.24	25.40	2.88	31.38	27.11	2.98	33.52	26.49	3.09	35.07	27.21	3.12	37.80	27.70	3.18	39.94	28.41	3.25
110	28.49	24.53	2.99	30.63	26.23	3.10	32.77	25.67	3.21	34.32	26.40	3.25	37.05	26.92	3.31	39.20	27.64	3.37
115	27.74	23.80	3.10	29.88	25.49	3.21	32.02	24.99	3.33	33.57	25.72	3.37	36.31	26.27	3.43	38.45	27.01	3.50
118	27.29	23.62	3.17	29.43	25.34	3.28	31.57	24.87	3.40	33.12	25.61	3.44	35.86	26.18	3.51	38.00	26.93	3.58
122	27.14	23.56	3.26	29.28	25.29	3.38	31.43	24.82	3.50	32.97	25.57	3.54	35.71	26.15	3.61	37.85	26.91	3.68

DB: Dry Bulb Temperature (°F) WB: Wet Bulb Temperature (°F) TC: Total Capacity (kBtu/h)
 SHC: Sensible Capacity (kBtu/h) PI: Power Input (kW) (includes compressor, indoor fan motor and outdoor fan motor)

- All capacities are net, evaporator fan motor heat is deducted.
- Cooling range can be extended from 5°F down to -4°F using the Low Ambient Wind Baffle Kit (sold separately).
- Grey shading indicates reference data. When operating at this temperature, these values can be different if the system is not running consistently.

4. Direct interpolation is permissible. ⚠ Do not extrapolate.

Capacity as rated: 0 ft. above sea level with 24.6 ft. of refrigerant piping. 0 ft. level difference between outdoor and indoor units.

Cooling capacity rating obtained with air entering the indoor unit at 80°F dry bulb (DB) and 67°F wet bulb (WB), and outdoor ambient conditions of 95°F dry bulb (DB) and 75°F wet bulb (WB).

PERFORMANCE DATA

Cooling Capacity

LC429HV

Cooling Capacity Table for LC429HV (LCN429HV + LUU420HV)

Table 28: LCN429HV / LUU420HV Cooling Capacities.

Outdoor Air Temp. (°F DB)	Indoor Air Temp. °F DB / °F WB																	
	68 / 57			73 / 61			77 / 64			80 / 67			86 / 72			90 / 75		
	TC	SHC	PI	TC	SHC	PI	TC	SHC	PI	TC	SHC	PI	TC	SHC	PI	TC	SHC	PI
-4	41.29	30.64	2.37	43.86	32.37	2.46	46.42	31.34	2.55	48.27	32.00	2.58	51.55	32.27	2.63	54.11	32.89	2.68
-0.4	41.27	30.82	2.40	43.83	32.56	2.49	46.40	31.53	2.58	48.25	32.19	2.61	51.52	32.46	2.66	54.08	33.08	2.71
5	41.24	31.09	2.44	43.80	32.84	2.53	46.36	31.80	2.62	48.21	32.47	2.65	51.48	32.75	2.70	54.04	33.37	2.75
10	41.20	31.34	2.47	43.76	33.11	2.56	46.32	32.06	2.66	48.17	32.73	2.69	51.44	33.01	2.74	54.00	33.63	2.79
15	41.17	31.59	2.51	43.73	33.37	2.60	46.29	32.31	2.70	48.13	32.99	2.73	51.40	33.27	2.78	53.96	33.90	2.83
20	41.14	31.83	2.55	43.70	33.63	2.64	46.25	32.56	2.73	48.10	33.25	2.77	51.36	33.53	2.82	53.92	34.16	2.87
25	41.11	32.08	2.58	43.66	33.89	2.68	46.22	32.81	2.77	48.06	33.50	2.81	51.32	33.79	2.86	53.88	34.43	2.92
30	41.08	32.33	2.62	43.63	34.15	2.71	46.18	33.06	2.81	48.02	33.76	2.84	51.28	34.05	2.90	53.83	34.69	2.96
35	41.05	32.57	2.65	43.60	34.41	2.75	46.15	33.32	2.85	47.99	34.02	2.88	51.24	34.30	2.94	53.79	34.95	3.00
40	41.02	32.82	2.69	43.56	34.67	2.79	46.11	33.57	2.89	47.95	34.27	2.92	51.20	34.56	2.98	53.75	35.22	3.04
45	40.98	33.06	2.73	43.53	34.93	2.83	46.07	33.82	2.93	47.91	34.53	2.96	51.17	34.82	3.02	53.71	35.48	3.08
50	40.95	33.31	2.76	43.50	35.18	2.86	46.04	34.07	2.97	47.88	34.78	3.00	51.13	35.08	3.06	53.67	35.74	3.12
55	40.92	33.55	2.80	43.46	35.44	2.90	46.00	34.32	3.01	47.84	35.04	3.04	51.09	35.33	3.10	53.63	36.00	3.16
60	40.89	33.79	2.83	43.43	35.70	2.94	45.97	34.57	3.04	47.80	35.29	3.08	51.05	35.59	3.14	53.59	36.27	3.20
65	40.86	34.04	2.87	43.40	35.96	2.97	45.93	34.81	3.08	47.77	35.55	3.12	51.01	35.85	3.18	53.55	36.53	3.24
70	40.83	34.28	2.91	43.36	36.21	3.01	45.90	35.06	3.12	47.73	35.80	3.16	50.97	36.10	3.22	53.50	36.79	3.28
75	39.84	33.72	3.06	42.37	35.66	3.17	44.90	34.57	3.29	46.73	35.32	3.33	49.96	35.67	3.39	52.49	36.37	3.46
80	38.86	33.14	3.22	41.39	35.10	3.34	43.91	34.07	3.46	45.73	34.84	3.50	48.95	35.22	3.56	51.48	35.94	3.64
85	37.89	32.54	3.38	40.41	34.51	3.50	42.92	33.53	3.63	44.74	34.32	3.67	47.96	34.74	3.74	50.47	35.49	3.81
90	36.91	31.92	3.53	39.43	33.91	3.66	41.94	32.99	3.80	43.75	33.80	3.84	46.96	34.25	3.91	49.47	35.03	3.99
95	35.86	31.59	3.69	38.36	33.60	3.82	40.85	32.74	3.96	42.00	33.05	4.01	45.85	34.07	4.09	48.35	34.87	4.17
100	34.98	30.74	3.85	37.48	32.75	3.99	39.98	31.96	4.13	41.46	32.54	4.18	44.98	33.34	4.26	47.47	34.16	4.34
105	34.11	29.89	4.00	36.61	31.91	4.15	39.11	31.18	4.30	40.91	32.03	4.35	44.10	32.61	4.43	46.60	33.44	4.52
110	33.24	28.87	4.16	35.74	30.87	4.31	38.23	30.22	4.47	40.04	31.07	4.52	43.23	31.68	4.61	45.73	32.53	4.70
115	32.37	28.01	4.32	34.86	30.01	4.47	37.36	29.42	4.64	39.17	30.28	4.69	42.36	30.92	4.78	44.86	31.79	4.88
118	31.84	27.81	4.41	34.34	29.82	4.57	36.84	29.27	4.74	38.64	30.14	4.79	41.83	30.82	4.88	44.33	31.70	4.98
122	31.67	27.74	4.54	34.16	29.76	4.70	36.66	29.22	4.87	38.47	30.10	4.93	41.66	30.78	5.02	44.16	31.67	5.12

DB: Dry Bulb Temperature (°F) WB: Wet Bulb Temperature (°F) TC: Total Capacity (kBtu/h)

SHC: Sensible Capacity (kBtu/h) PI: Power Input (kW) (includes compressor, indoor fan motor and outdoor fan motor)

1. All capacities are net, evaporator fan motor heat is deducted.
2. Cooling range can be extended from 5°F down to -4°F using the Low Ambient Wind Baffle Kit (sold separately).
3. Grey shading indicates reference data. When operating at this temperature, these values can be different if the system is not running consistently.

4. Direct interpolation is permissible. ⚠ Do not extrapolate.

Capacity as rated: 0 ft. above sea level with 24.6 ft. of refrigerant piping. 0 ft. level difference between outdoor and indoor units.

Cooling capacity rating obtained with air entering the indoor unit at 80°F dry bulb (DB) and 67°F wet bulb (WB), and outdoor ambient conditions of 95°F dry bulb (DB) and 75°F wet bulb (WB).

PERFORMANCE DATA

Heating Capacity LC098HV, LC128HV

Heating Capacity Table for LC098HV (LCN098HV4 + LUU090HV)

Table 29: LCN098HV4 / LUU090HV Heating Capacities.

Outdoor Air Temp.		Indoor Air Temp. °F DB											
°F DB	°F WB	61		64		68		70		72		75	
		TC	PI	TC	PI	TC	PI	TC	PI	TC	PI	TC	PI
-4	-4.4	4.38	0.61	4.06	0.63	4.03	0.64	3.99	0.64	3.95	0.65	3.77	0.67
0	-0.4	5.22	0.62	4.91	0.64	4.84	0.65	4.77	0.65	4.71	0.66	4.51	0.68
5	4.5	6.22	0.63	5.93	0.65	5.79	0.66	5.70	0.67	5.62	0.68	5.39	0.70
10	9	6.89	0.63	6.61	0.66	6.43	0.67	6.32	0.68	6.23	0.69	5.98	0.71
17	15	7.63	0.65	7.36	0.67	7.13	0.69	7.00	0.70	6.90	0.71	6.63	0.73
20	19	8.07	0.66	7.82	0.68	7.55	0.70	7.41	0.71	7.30	0.72	7.02	0.74
25	23	8.82	0.67	8.56	0.69	8.26	0.72	8.10	0.73	7.98	0.74	7.68	0.76
30	28	9.57	0.69	9.28	0.71	8.96	0.73	8.79	0.75	8.66	0.76	8.34	0.78
35	32	10.33	0.71	10.00	0.73	9.66	0.75	9.48	0.77	9.35	0.78	9.01	0.80
40	36	10.85	0.73	10.55	0.75	10.21	0.78	10.04	0.79	9.89	0.81	9.54	0.83
45	41	11.51	0.75	11.24	0.78	10.91	0.80	10.72	0.82	10.58	0.83	10.20	0.86
47	43	11.77	0.77	11.51	0.79	11.18	0.82	11.00	0.83	10.85	0.84	10.46	0.87
50	46	11.81	0.76	11.57	0.78	11.28	0.81	11.12	0.82	10.99	0.83	10.62	0.85
55	51	11.87	0.75	11.67	0.77	11.45	0.79	11.32	0.80	11.22	0.81	10.89	0.82
60	56	11.92	0.74	11.77	0.76	11.62	0.77	11.53	0.78	11.45	0.78	11.15	0.80
63	59	11.96	0.74	11.83	0.75	11.73	0.76	11.65	0.77	11.58	0.77	11.31	0.78
68	64	11.99	0.73	11.89	0.74	11.83	0.75	11.77	0.75	11.72	0.76	11.48	0.76

Heating Capacity Table for LC128HV (LCN128HV4 + LUU120HV)

Table 30: LCN128HV4 / LUU120HV Heating Capacities.

Outdoor Air Temp.		Indoor Air Temp. °F DB											
°F DB	°F WB	61		64		68		70		72		75	
		TC	PI	TC	PI	TC	PI	TC	PI	TC	PI	TC	PI
-4	-4.4	6.04	0.83	5.61	0.86	5.56	0.87	5.50	0.88	5.44	0.88	5.20	0.92
0	-0.4	7.04	0.85	6.63	0.88	6.52	0.89	6.43	0.90	6.36	0.91	6.09	0.94
5	4.5	8.24	0.87	7.85	0.90	7.66	0.92	7.54	0.93	7.44	0.93	7.14	0.97
10	9	9.03	0.88	8.67	0.91	8.43	0.94	8.28	0.95	8.17	0.96	7.85	0.99
17	15	9.91	0.91	9.57	0.94	9.27	0.96	9.10	0.98	8.97	0.99	8.62	1.02
20	19	10.45	0.92	10.11	0.95	9.78	0.98	9.60	1.00	9.45	1.02	9.09	1.04
25	23	11.34	0.95	11.00	0.98	10.62	1.01	10.42	1.04	10.26	1.05	9.87	1.08
30	28	12.24	0.98	11.86	1.02	11.46	1.05	11.25	1.07	11.08	1.09	10.67	1.12
35	32	13.14	1.02	12.73	1.05	12.29	1.08	12.07	1.10	11.89	1.12	11.46	1.15
40	36	13.81	1.05	13.43	1.08	13.00	1.11	12.77	1.14	12.59	1.15	12.14	1.18
45	41	14.65	1.08	14.30	1.12	13.88	1.15	13.65	1.17	13.46	1.19	12.98	1.23
47	43	14.99	1.10	14.65	1.13	14.23	1.17	14.00	1.19	13.81	1.21	13.31	1.24
50	46	15.03	1.09	14.73	1.12	14.36	1.16	14.15	1.17	13.99	1.19	13.52	1.22
55	51	15.10	1.08	14.85	1.11	14.58	1.13	14.41	1.14	14.28	1.15	13.85	1.18
60	56	15.18	1.07	14.98	1.09	14.80	1.11	14.67	1.12	14.57	1.12	14.19	1.14
63	59	15.22	1.06	15.05	1.08	14.92	1.09	14.82	1.10	14.74	1.10	14.40	1.12
68	64	15.26	1.05	15.13	1.07	15.06	1.08	14.98	1.08	14.92	1.08	14.61	1.09

DB: Dry Bulb Temperature (°F) WB: Wet Bulb Temperature (°F) TC: Total Capacity (kBtu/h)
PI: Power Input (kW) (includes compressor, indoor fan motor and outdoor fan motor)

1. All capacities are net, evaporator fan motor heat is deducted.
2. Direct interpolation is permissible. ⊙ Do not extrapolate.

Capacity as rated: 0 ft. above sea level with 24.6 ft. of refrigerant piping, 0 ft. level difference between outdoor and indoor units.

Heating capacity rating obtained with air entering the indoor unit at 70°F dry bulb (DB) and 60°F wet bulb (WB), and outdoor ambient conditions of 47°F dry bulb (DB) and 43°F wet bulb (WB).

PERFORMANCE DATA

Heating Capacity

LC188HV, LC249HV

Heating Capacity Table for LC188HV (LCN188HV4 + LUU180HV)

Table 32: LCN188HV4 / LUU180HV Heating Capacities.

Outdoor Air Temp.		Indoor Air Temp. °F DB											
°F DB	°F WB	61		64		68		70		72		75	
		TC	PI	TC	PI	TC	PI	TC	PI	TC	PI	TC	PI
-4	-4.4	9.61	6.86	8.97	7.08	8.87	7.30	8.76	7.42	8.67	7.51	8.29	7.73
0	-0.4	10.70	6.43	10.10	6.64	9.92	6.84	9.78	6.96	9.66	7.05	9.26	7.25
5	4.5	12.01	5.91	11.46	6.10	11.18	6.29	10.99	6.39	10.85	6.47	10.41	6.66
10	9	12.88	5.43	12.36	5.60	12.01	5.78	11.81	5.87	11.64	5.95	11.18	6.12
17	15	13.84	4.79	13.36	4.94	12.93	5.10	12.70	5.18	12.51	5.25	12.03	5.40
20	19	14.42	4.36	13.96	4.50	13.49	4.64	13.24	4.72	13.04	4.78	12.55	4.92
25	23	15.39	3.93	14.94	4.06	14.42	4.19	14.15	4.26	13.93	4.31	13.40	4.44
30	28	16.38	3.40	15.87	3.51	15.33	3.62	15.05	3.68	14.82	3.73	14.28	3.84
35	32	17.37	2.97	16.82	3.07	16.24	3.17	15.95	3.22	15.72	3.26	15.15	3.36
40	36	18.25	2.55	17.74	2.63	17.18	2.71	16.88	2.76	16.64	2.79	16.04	2.88
45	41	19.36	2.01	18.90	2.08	18.34	2.14	18.04	2.18	17.79	2.21	17.15	2.28
47	43	19.80	1.80	19.36	1.86	18.81	1.92	18.50	1.95	18.25	1.98	17.59	2.04
50	46	19.86	1.79	19.46	1.84	18.98	1.89	18.70	1.92	18.48	1.94	17.86	2.00
55	51	19.96	1.77	19.63	1.81	19.26	1.85	19.04	1.88	18.87	1.89	18.31	1.93
60	56	20.06	1.75	19.79	1.78	19.55	1.82	19.38	1.83	19.25	1.84	18.76	1.87
63	59	20.11	1.74	19.89	1.77	19.72	1.79	19.59	1.80	19.48	1.81	19.03	1.83
68	64	20.17	1.73	19.99	1.75	19.90	1.77	19.79	1.77	19.71	1.78	19.30	1.79

Heating Capacity Table for LC249HV (LCN249HV + LUU240HV)

Table 31: LCN249HV / LUU240HV Heating Capacities.

Outdoor Air Temp.		Indoor Air Temp. °F DB											
°F DB	°F WB	61		64		68		70		72		75	
		TC	PI	TC	PI	TC	PI	TC	PI	TC	PI	TC	PI
-4	-4.4	13.03	1.46	12.24	1.50	12.06	1.55	11.89	1.57	11.76	1.59	11.26	1.64
0	-0.4	14.47	1.51	13.71	1.56	13.44	1.61	13.23	1.63	13.07	1.65	12.53	1.70
5	4.5	16.07	1.58	15.34	1.63	14.96	1.68	14.72	1.71	14.52	1.73	13.94	1.78
10	9	17.43	1.65	16.73	1.7	16.26	1.75	15.98	1.78	15.76	1.8	15.14	1.85
17	15	18.63	1.75	18.21	1.81	17.69	1.87	17.40	1.90	17.17	1.93	16.54	1.98
20	19	20.09	1.80	19.64	1.86	19.08	1.92	18.77	1.95	18.52	1.98	17.85	2.04
25	23	21.56	1.84	21.08	1.91	20.48	1.97	20.14	2.00	19.88	2.03	19.15	2.09
30	28	23.40	1.90	22.87	1.96	22.22	2.03	21.86	2.06	21.57	2.09	20.78	2.15
35	32	24.86	1.95	24.31	2.01	23.61	2.08	23.23	2.11	22.92	2.14	22.09	2.21
40	36	26.33	1.99	25.74	2.06	25.01	2.13	24.60	2.16	24.27	2.19	23.39	2.26
45	41	28.17	2.05	27.54	2.12	26.75	2.19	26.31	2.23	25.96	2.26	25.02	2.32
47	43	28.90	2.07	28.26	2.14	27.45	2.21	27	2.25	26.64	2.28	25.67	2.35
50	46	28.99	2.06	28.40	2.12	27.70	2.18	27.30	2.22	26.98	2.24	26.07	2.30
55	51	29.13	2.04	28.65	2.09	28.12	2.14	27.79	2.16	27.54	2.18	26.72	2.23
60	56	29.27	2.02	28.89	2.06	28.53	2.09	28.29	2.11	28.09	2.12	27.38	2.16
63	59	29.35	2.01	29.03	2.04	28.78	2.07	28.59	2.08	28.43	2.09	27.77	2.11
68	64	29.44	1.99	29.18	2.02	29.04	2.04	28.89	2.05	28.77	2.05	28.17	2.07

DB: Dry Bulb Temperature (°F) WB: Wet Bulb Temperature (°F) TC: Total Capacity (kBtu/h)
 PI: Power Input (kW) (includes compressor, indoor fan motor and outdoor fan motor)

1. All capacities are net, evaporator fan motor heat is deducted.
2. Direct interpolation is permissible. ⚠ Do not extrapolate.

Capacity as rated: 0 ft. above sea level with 24.6 ft. of refrigerant piping. 0 ft. level difference between outdoor and indoor units.

Heating capacity rating obtained with air entering the indoor unit at 70°F dry bulb (DB) and 60°F wet bulb (WB), and outdoor ambient conditions of 47°F dry bulb (DB) and 43°F wet bulb (WB).

PERFORMANCE DATA

Heating Capacity LC369HV, LC429HV

Heating Capacity Table for LC369HV (LCN369HV + LUU360HV)

Table 33: LCN369HV / LUU360HV Heating Capacities.

Outdoor Air Temp.		Indoor Air Temp. °F DB											
°F DB	°F WB	61		64		68		70		72		75	
		TC	PI	TC	PI	TC	PI	TC	PI	TC	PI	TC	PI
-4	-4.4	15.17	2.04	14.16	2.10	14.01	2.17	13.83	2.20	13.68	2.23	13.08	2.29
0	-0.4	17.79	2.12	16.81	2.18	16.50	2.25	16.26	2.29	16.06	2.31	15.39	2.38
5	4.5	20.70	2.21	19.74	2.28	19.26	2.35	18.95	2.39	18.70	2.42	17.95	2.49
10	9	23.18	2.30	22.24	2.37	21.62	2.44	21.25	2.48	20.95	2.52	20.12	2.59
17	15	25.69	2.41	25.12	2.49	24.40	2.57	24.00	2.61	23.68	2.65	22.82	2.73
20	19	28.14	2.50	27.51	2.58	26.72	2.66	26.29	2.71	25.94	2.74	24.99	2.83
25	23	30.58	2.58	29.90	2.67	29.05	2.75	28.57	2.80	28.19	2.84	27.17	2.92
30	28	33.64	2.69	32.89	2.78	31.95	2.87	31.43	2.91	31.01	2.95	29.88	3.04
35	32	36.09	2.77	35.28	2.86	34.27	2.96	33.71	3.01	33.27	3.05	32.06	3.14
40	36	38.54	2.86	37.67	2.95	36.60	3.05	36.00	3.10	35.52	3.14	34.23	3.24
45	41	41.59	2.96	40.66	3.06	39.50	3.16	38.86	3.21	38.34	3.26	36.95	3.36
47	43	42.82	3.01	41.86	3.11	40.66	3.20	40.00	3.26	39.47	3.30	38.03	3.40
50	46	42.94	2.99	42.08	3.08	41.04	3.17	40.44	3.21	39.97	3.25	38.62	3.34
55	51	43.15	2.96	42.44	3.03	41.65	3.10	41.18	3.14	40.79	3.16	39.59	3.23
60	56	43.36	2.92	42.80	2.98	42.27	3.04	41.91	3.06	41.62	3.08	40.56	3.12
63	59	43.49	2.91	43.01	2.95	42.64	3.00	42.35	3.01	42.12	3.02	41.14	3.06
68	64	43.61	2.89	43.23	2.92	43.02	2.96	42.80	2.97	42.62	2.97	41.73	3.00

Heating Capacity Table for LC429HV (LCN429HV + LUU420HV)

Table 34: LCN429HV / LUU420HV Heating Capacities.

Outdoor Air Temp.		Indoor Air Temp. °F DB											
°F DB	°F WB	61		64		68		70		72		75	
		TC	PI	TC	PI	TC	PI	TC	PI	TC	PI	TC	PI
-4	-4.4	13.09	2.11	12.11	2.18	12.05	2.24	11.91	2.28	11.80	2.31	11.27	2.37
0	-0.4	16.74	2.25	15.75	2.32	15.50	2.39	15.28	2.43	15.11	2.46	14.47	2.53
5	4.5	20.77	2.43	19.78	2.50	19.32	2.58	19.01	2.62	18.76	2.65	18.00	2.73
10	9	24.20	2.58	23.22	2.66	22.57	2.75	22.19	2.79	21.88	2.83	21.02	2.91
17	15	29.97	2.57	29.30	2.65	28.47	2.73	28.00	2.78	27.63	2.82	26.62	2.90
20	19	32.88	2.68	32.14	2.77	31.22	2.85	30.71	2.90	30.31	2.94	29.20	3.03
25	23	35.78	2.79	34.98	2.88	33.98	2.97	33.43	3.02	32.98	3.07	31.78	3.16
30	28	39.41	2.93	38.53	3.03	37.43	3.12	36.82	3.18	36.33	3.22	35.01	3.32
35	32	42.32	3.04	41.37	3.14	40.19	3.24	39.54	3.30	39.01	3.34	37.59	3.44
40	36	45.23	3.15	44.22	3.26	42.95	3.36	42.25	3.42	41.69	3.46	40.17	3.57
45	41	48.86	3.29	47.77	3.40	46.40	3.51	45.64	3.57	45.04	3.62	43.40	3.73
47	43	50.31	3.35	49.19	3.46	47.78	3.57	47.00	3.63	46.38	3.68	44.69	3.79
50	46	50.46	3.33	49.44	3.43	48.22	3.52	47.52	3.58	46.96	3.62	45.37	3.72
55	51	50.70	3.29	49.86	3.37	48.94	3.45	48.38	3.49	47.93	3.52	46.51	3.60
60	56	50.95	3.26	50.29	3.32	49.67	3.38	49.24	3.40	48.90	3.43	47.65	3.48
63	59	51.10	3.23	50.54	3.29	50.10	3.34	49.76	3.35	49.49	3.37	48.34	3.41
68	64	51.25	3.21	50.80	3.25	50.54	3.29	50.29	3.30	50.08	3.31	49.03	3.34

DB: Dry Bulb Temperature (°F) WB: Wet Bulb Temperature (°F) TC: Total Capacity (kBtu/h)
PI: Power Input (kW) (includes compressor, indoor fan motor and outdoor fan motor)

1. All capacities are net, evaporator fan motor heat is deducted.
2. Direct interpolation is permissible. Ⓞ Do not extrapolate.

Capacity as rated: 0 ft. above sea level with 24.6 ft. of refrigerant piping, 0 ft. level difference between outdoor and indoor units.

Heating capacity rating obtained with air entering the indoor unit at 70°F dry bulb (DB) and 60°F wet bulb (WB), and outdoor ambient conditions of 47°F dry bulb (DB) and 43°F wet bulb (WB).



PERFORMANCE DATA

Maximum Cooling Capacity

LC249HV

Maximum Cooling Capacity Table for LC249HV (LCN249HV + LUU240HV)

Table 35: LCN249HV / LUU240HV Maximum Cooling Capacities.

Outdoor Air Temp. (°F DB)	Indoor Air Temp. °F DB / °F WB																	
	68 / 57			73 / 61			77 / 64			80 / 67			86 / 72			90 / 75		
	TC	SHC	PI	TC	SHC	PI	TC	SHC	PI	TC	SHC	PI	TC	SHC	PI	TC	SHC	PI
-4	27.53	18.69	1.80	29.24	19.75	1.86	30.95	19.12	1.93	32.18	19.52	1.95	34.37	19.69	1.99	36.08	20.06	2.03
-0.4	27.51	18.80	1.82	29.22	19.86	1.88	30.93	19.23	1.95	32.16	19.64	1.98	34.35	19.80	2.01	36.06	20.18	2.05
5	27.49	18.97	1.85	29.20	20.03	1.92	30.90	19.40	1.99	32.14	19.81	2.01	34.32	19.97	2.05	36.03	20.35	2.09
10	27.47	19.12	1.88	29.18	20.19	1.94	30.88	19.55	2.01	32.11	19.96	2.04	34.29	20.13	2.08	36.00	20.51	2.12
15	27.45	19.27	1.90	29.15	20.35	1.97	30.86	19.71	2.04	32.09	20.12	2.07	34.27	20.29	2.11	35.97	20.68	2.15
20	27.43	19.42	1.93	29.13	20.51	2.00	30.83	19.86	2.07	32.06	20.28	2.10	34.24	20.45	2.14	35.94	20.84	2.18
25	27.41	19.57	1.96	29.11	20.67	2.03	30.81	20.02	2.10	32.04	20.44	2.13	34.21	20.61	2.17	35.92	21.00	2.21
30	27.39	19.72	1.98	29.09	20.83	2.06	30.79	20.17	2.13	32.02	20.59	2.16	34.19	20.77	2.20	35.89	21.16	2.24
35	27.36	19.87	2.01	29.06	20.99	2.09	30.76	20.32	2.16	31.99	20.75	2.19	34.16	20.93	2.23	35.86	21.32	2.27
40	27.34	20.02	2.04	29.04	21.15	2.11	30.74	20.48	2.19	31.97	20.91	2.22	34.14	21.08	2.26	35.83	21.48	2.30
45	27.32	20.17	2.07	29.02	21.30	2.14	30.72	20.63	2.22	31.94	21.06	2.25	34.11	21.24	2.29	35.81	21.64	2.33
50	27.30	20.32	2.09	29.00	21.46	2.17	30.69	20.78	2.25	31.92	21.22	2.28	34.08	21.40	2.32	35.78	21.80	2.36
55	27.28	20.47	2.12	28.98	21.62	2.20	30.67	20.93	2.28	31.89	21.37	2.31	34.06	21.55	2.35	35.75	21.96	2.40
60	27.26	20.61	2.15	28.95	21.78	2.23	30.65	21.08	2.31	31.87	21.53	2.33	34.03	21.71	2.38	35.72	22.12	2.43
65	27.24	20.76	2.18	28.93	21.93	2.26	30.62	21.24	2.34	31.84	21.68	2.36	34.01	21.87	2.41	35.70	22.28	2.46
70	27.22	20.91	2.20	28.91	22.09	2.28	30.60	21.39	2.37	31.82	21.84	2.39	33.98	22.02	2.44	35.67	22.44	2.49
75	26.56	20.57	2.32	28.25	21.75	2.41	29.94	21.09	2.49	31.15	21.55	2.52	33.31	21.76	2.57	34.99	22.19	2.62
80	25.91	20.21	2.44	27.59	21.41	2.53	29.27	20.78	2.62	30.49	21.25	2.65	32.64	21.48	2.70	34.32	21.93	2.76
85	25.26	19.85	2.56	26.94	21.05	2.65	28.61	20.46	2.75	29.83	20.94	2.78	31.97	21.19	2.83	33.65	21.65	2.89
90	24.61	19.47	2.68	26.28	20.68	2.78	27.96	20.12	2.88	29.17	20.61	2.91	31.30	20.89	2.97	32.98	21.37	3.02
95	23.91	19.27	2.80	25.57	20.50	2.90	27.24	19.97	3.01	28.00	20.16	3.04	30.57	20.78	3.10	32.23	21.27	3.16
100	23.32	18.75	2.92	24.99	19.98	3.02	26.65	19.49	3.13	27.64	19.85	3.17	29.98	20.33	3.23	31.65	20.83	3.29
105	22.74	18.23	3.04	24.41	19.46	3.15	26.07	19.02	3.26	27.27	19.54	3.30	29.40	19.89	3.36	31.07	20.40	3.43
110	22.16	17.61	3.15	23.82	18.83	3.27	25.49	18.43	3.39	26.69	18.95	3.43	28.82	19.32	3.49	30.49	19.84	3.56
115	21.58	17.08	3.27	23.24	18.30	3.39	24.91	17.94	3.52	26.11	18.47	3.56	28.24	18.86	3.62	29.90	19.39	3.70
118	21.23	16.96	3.34	22.89	18.19	3.47	24.56	17.85	3.59	25.76	18.39	3.63	27.89	18.80	3.70	29.55	19.34	3.78
122	21.11	16.92	3.44	22.78	18.15	3.56	24.44	17.82	3.69	25.64	18.36	3.74	27.77	18.78	3.81	29.44	19.32	3.88

DB: Dry Bulb Temperature (°F) WB: Wet Bulb Temperature (°F) TC: Total Capacity (kBtu/h)
 SHC: Sensible Capacity (kBtu/h) PI: Power Input (kW) (includes compressor, indoor fan motor and outdoor fan motor)

1. All capacities are net, evaporator fan motor heat is deducted.
2. Cooling range can be extended from 5°F down to -4°F using the Low Ambient Wind Baffle Kit (sold separately).
3. Grey shading indicates reference data. When operating at this temperature, these values can be different if the system is not running consistently.

4. Direct interpolation is permissible. ⊘ Do not extrapolate.

Capacity as rated: 0 ft. above sea level with 24.6 ft. of refrigerant piping, 0 ft. level difference between outdoor and indoor units.

Cooling capacity rating obtained with air entering the indoor unit at 80°F dry bulb (DB) and 67°F wet bulb (WB), and outdoor ambient conditions of 95°F dry bulb (DB) and 75°F wet bulb (WB).

PERFORMANCE DATA

Maximum Cooling Capacity LC369HV

Maximum Cooling Capacity Table for LC369HV (LCN369HV + LUU360HV)

Table 36: LCN369HV / LUU360HV Maximum Cooling Capacities.

Outdoor Air Temp. (°F DB)	Indoor Air Temp. °F DB / °F WB																	
	68 / 57			73 / 61			77 / 64			80 / 67			86 / 72			90 / 75		
	TC	SHC	PI	TC	SHC	PI	TC	SHC	PI	TC	SHC	PI	TC	SHC	PI	TC	SHC	PI
-4	41.29	28.43	2.31	43.86	30.03	2.39	46.42	29.08	2.48	48.27	29.69	2.51	51.55	29.94	2.55	54.11	30.51	2.61
-0.4	41.27	28.59	2.33	43.83	30.21	2.42	46.40	29.25	2.51	48.25	29.86	2.53	51.52	30.12	2.58	54.08	30.69	2.63
5	41.24	28.84	2.37	43.80	30.47	2.46	46.36	29.50	2.55	48.21	30.12	2.58	51.48	30.38	2.62	54.04	30.95	2.68
10	41.20	29.07	2.41	43.76	30.71	2.49	46.32	29.74	2.58	48.17	30.36	2.61	51.44	30.62	2.66	54.00	31.20	2.72
15	41.17	29.30	2.44	43.73	30.95	2.53	46.29	29.97	2.62	48.13	30.60	2.65	51.40	30.86	2.70	53.96	31.45	2.76
20	41.14	29.53	2.48	43.70	31.20	2.57	46.25	30.21	2.66	48.10	30.84	2.69	51.36	31.10	2.74	53.92	31.69	2.80
25	41.11	29.76	2.51	43.66	31.44	2.60	46.22	30.44	2.70	48.06	31.08	2.73	51.32	31.34	2.78	53.88	31.94	2.84
30	41.08	29.99	2.55	43.63	31.68	2.64	46.18	30.67	2.74	48.02	31.32	2.77	51.28	31.58	2.82	53.83	32.18	2.88
35	41.05	30.22	2.58	43.60	31.92	2.68	46.15	30.91	2.77	47.99	31.56	2.80	51.24	31.82	2.86	53.79	32.43	2.91
40	41.02	30.44	2.62	43.56	32.16	2.71	46.11	31.14	2.81	47.95	31.80	2.84	51.20	32.06	2.90	53.75	32.67	2.95
45	40.98	30.67	2.65	43.53	32.40	2.75	46.07	31.37	2.85	47.91	32.03	2.88	51.17	32.30	2.93	53.71	32.91	2.99
50	40.95	30.90	2.69	43.50	32.64	2.78	46.04	31.60	2.89	47.88	32.27	2.92	51.13	32.54	2.97	53.67	33.16	3.03
55	40.92	31.12	2.72	43.46	32.88	2.82	46.00	31.84	2.92	47.84	32.51	2.96	51.09	32.78	3.01	53.63	33.40	3.07
60	40.89	31.35	2.76	43.43	33.12	2.86	45.97	32.07	2.96	47.80	32.74	3.00	51.05	33.02	3.05	53.59	33.64	3.11
65	40.86	31.58	2.79	43.40	33.36	2.89	45.93	32.30	3.00	47.77	32.98	3.03	51.01	33.26	3.09	53.55	33.89	3.15
70	40.83	31.80	2.83	43.36	33.59	2.93	45.90	32.53	3.04	47.73	33.21	3.07	50.97	33.49	3.13	53.50	34.13	3.19
75	39.84	31.28	2.98	42.37	33.08	3.09	44.90	32.07	3.20	46.73	32.77	3.24	49.96	33.09	3.30	52.49	33.74	3.36
80	38.86	30.74	3.13	41.39	32.56	3.25	43.91	31.60	3.36	45.73	32.32	3.40	48.95	32.67	3.47	51.48	33.35	3.54
85	37.89	30.18	3.28	40.41	32.01	3.40	42.92	31.11	3.53	44.74	31.84	3.57	47.96	32.23	3.64	50.47	32.92	3.71
90	36.91	29.61	3.44	39.43	31.46	3.56	41.94	30.61	3.69	43.75	31.35	3.73	46.96	31.78	3.80	49.47	32.49	3.88
95	35.86	29.30	3.59	38.36	31.17	3.72	40.85	30.37	3.86	42.00	30.66	3.90	45.85	31.61	3.97	48.35	32.35	4.05
100	34.98	28.51	3.74	37.48	30.39	3.88	39.98	29.65	4.02	41.46	30.19	4.07	44.98	30.93	4.14	47.47	31.69	4.23
105	34.11	27.73	3.89	36.61	29.60	4.04	39.11	28.93	4.18	40.91	29.71	4.23	44.10	30.25	4.31	46.60	31.02	4.40
110	33.24	26.78	4.05	35.74	28.64	4.19	38.23	28.03	4.35	40.04	28.82	4.40	43.23	29.39	4.48	45.73	30.17	4.57
115	32.37	25.98	4.20	34.86	27.84	4.35	37.36	27.29	4.51	39.17	28.09	4.56	42.36	28.69	4.65	44.86	29.49	4.74
118	31.84	25.79	4.29	34.34	27.67	4.45	36.84	27.15	4.61	38.64	27.96	4.66	41.83	28.59	4.75	44.33	29.41	4.85
122	31.67	25.73	4.41	34.16	27.61	4.57	36.66	27.10	4.74	38.47	27.92	4.79	41.66	28.56	4.88	44.16	29.38	4.98

DB: Dry Bulb Temperature (°F) WB: Wet Bulb Temperature (°F) TC: Total Capacity (kBtu/h)
SHC: Sensible Capacity (kBtu/h) PI: Power Input (kW) (includes compressor, indoor fan motor and outdoor fan motor)

1. All capacities are net, evaporator fan motor heat is deducted.
2. Cooling range can be extended from 5°F down to -4°F using the Low Ambient Wind Baffle Kit (sold separately).
3. Grey shading indicates reference data. When operating at this temperature, these values can be different if the system is not running consistently.

4. Direct interpolation is permissible. ⊘ Do not extrapolate.

Capacity as rated: 0 ft. above sea level with 24.6 ft. of refrigerant piping, 0 ft. level difference between outdoor and indoor units.

Cooling capacity rating obtained with air entering the indoor unit at 80°F dry bulb (DB) and 67°F wet bulb (WB), and outdoor ambient conditions of 95°F dry bulb (DB) and 75°F wet bulb (WB).

PERFORMANCE DATA

Maximum Cooling Capacity

LC429HV

Maximum Cooling Capacity Table for LC429HV (LCN429HV + LUU420HV)

Table 37: LCN429HV / LUU420HV Maximum Cooling Capacities.

Outdoor Air Temp. (°F DB)	Indoor Air Temp. °F DB / °F WB																	
	68 / 57			73 / 61			77 / 64			80 / 67			86 / 72			90 / 75		
	TC	SHC	PI	TC	SHC	PI	TC	SHC	PI	TC	SHC	PI	TC	SHC	PI	TC	SHC	PI
-4	47.88	33.87	3.25	50.85	35.78	3.37	53.83	34.64	3.50	55.97	35.37	3.54	59.77	35.67	3.60	62.75	36.34	3.67
-0.4	47.85	34.06	3.29	50.82	35.98	3.41	53.80	34.84	3.53	55.94	35.58	3.57	59.74	35.88	3.64	62.71	36.56	3.72
5	47.81	34.36	3.34	50.78	36.30	3.47	53.75	35.15	3.59	55.90	35.89	3.63	59.69	36.19	3.70	62.66	36.87	3.78
10	47.78	34.63	3.39	50.74	36.59	3.52	53.71	35.43	3.64	55.85	36.17	3.69	59.65	36.48	3.76	62.61	37.17	3.83
15	47.74	34.91	3.44	50.71	36.88	3.57	53.67	35.71	3.70	55.81	36.46	3.74	59.60	36.76	3.81	62.56	37.46	3.89
20	47.70	35.18	3.49	50.67	37.16	3.62	53.63	35.98	3.75	55.77	36.74	3.79	59.55	37.05	3.87	62.52	37.75	3.94
25	47.67	35.45	3.54	50.63	37.45	3.67	53.59	36.26	3.80	55.73	37.03	3.85	59.51	37.34	3.92	62.47	38.05	4.00
30	47.63	35.73	3.59	50.59	37.74	3.72	53.55	36.54	3.86	55.68	37.31	3.90	59.46	37.63	3.97	62.42	38.34	4.05
35	47.59	36.00	3.64	50.55	38.03	3.77	53.51	36.82	3.91	55.64	37.59	3.96	59.42	37.91	4.03	62.37	38.63	4.11
40	47.56	36.27	3.69	50.51	38.31	3.82	53.47	37.10	3.96	55.60	37.88	4.01	59.37	38.20	4.08	62.33	38.92	4.17
45	47.52	36.54	3.74	50.47	38.60	3.88	53.42	37.37	4.02	55.56	38.16	4.06	59.33	38.48	4.14	62.28	39.21	4.22
50	47.49	36.81	3.79	50.43	38.88	3.93	53.38	37.65	4.07	55.51	38.44	4.12	59.28	38.77	4.19	62.23	39.50	4.28
55	47.45	37.08	3.84	50.40	39.17	3.98	53.34	37.93	4.12	55.47	38.72	4.17	59.24	39.05	4.25	62.18	39.79	4.33
60	47.41	37.35	3.89	50.36	39.45	4.03	53.30	38.20	4.18	55.43	39.00	4.22	59.19	39.33	4.30	62.14	40.08	4.39
65	47.38	37.62	3.94	50.32	39.74	4.08	53.26	38.48	4.23	55.39	39.29	4.28	59.15	39.62	4.36	62.09	40.37	4.45
70	47.34	37.88	3.99	50.28	40.02	4.13	53.22	38.75	4.28	55.34	39.57	4.33	59.10	39.90	4.41	62.04	40.65	4.50
75	46.20	37.26	4.20	49.13	39.41	4.35	52.07	38.21	4.51	54.18	39.04	4.57	57.93	39.42	4.65	60.86	40.20	4.74
80	45.06	36.62	4.42	47.99	38.79	4.58	50.91	37.65	4.74	53.03	38.50	4.80	56.76	38.92	4.89	59.69	39.72	4.99
85	43.93	35.96	4.63	46.85	38.14	4.80	49.77	37.06	4.98	51.88	37.93	5.03	55.61	38.39	5.13	58.52	39.22	5.23
90	42.80	35.28	4.85	45.71	37.47	5.02	48.63	36.46	5.21	50.73	37.35	5.27	54.45	37.86	5.36	57.36	38.71	5.47
95	41.58	34.91	5.06	44.47	37.14	5.25	47.37	36.18	5.44	48.70	36.53	5.50	53.16	37.65	5.60	56.06	38.54	5.72
100	40.57	33.97	5.28	43.46	36.20	5.47	46.36	35.32	5.67	48.07	35.96	5.73	52.15	36.84	5.84	55.05	37.75	5.96
105	39.55	33.04	5.49	42.45	35.26	5.69	45.35	34.46	5.90	47.44	35.40	5.97	51.14	36.03	6.08	54.04	36.96	6.20
110	38.54	31.91	5.71	41.44	34.12	5.91	44.33	33.39	6.13	46.43	34.34	6.20	50.13	35.01	6.32	53.02	35.95	6.44
115	37.53	30.95	5.92	40.42	33.16	6.14	43.32	32.51	6.36	45.41	33.46	6.43	49.11	34.17	6.56	52.01	35.13	6.69
118	36.92	30.73	6.05	39.82	32.96	6.27	42.71	32.34	6.50	44.81	33.31	6.57	48.51	34.06	6.70	51.40	35.03	6.83
122	36.72	30.65	6.22	39.61	32.89	6.45	42.51	32.29	6.68	44.60	33.26	6.76	48.30	34.02	6.89	51.20	35.00	7.03

DB: Dry Bulb Temperature (°F) WB: Wet Bulb Temperature (°F) TC: Total Capacity (kBtu/h)
 SHC: Sensible Capacity (kBtu/h) PI: Power Input (kW) (includes compressor, indoor fan motor and outdoor fan motor)

- All capacities are net, evaporator fan motor heat is deducted.
- Cooling range can be extended from 5°F down to -4°F using the Low Ambient Wind Baffle Kit (sold separately).
- Grey shading indicates reference data. When operating at this temperature, these values can be different if the system is not running consistently.

4. Direct interpolation is permissible. ⊖ Do not extrapolate.

Capacity as rated: 0 ft. above sea level with 24.6 ft. of refrigerant piping. 0 ft. level difference between outdoor and indoor units.

Cooling capacity rating obtained with air entering the indoor unit at 80°F dry bulb (DB) and 67°F wet bulb (WB), and outdoor ambient conditions of 95°F dry bulb (DB) and 75°F wet bulb (WB).

PERFORMANCE DATA

Maximum Heating Capacity

LC098HV, LC128HV

Maximum Heating Capacity Table for LC098HV (LCN098HV4 + LUU090HV)

Table 38: LCN098HV4 / LUU090HV Maximum Heating Capacities.

Outdoor Air Temp.		Indoor Air Temp. °F DB											
°F DB	°F WB	61		64		68		70		72		75	
		TC	PI	TC	PI	TC	PI	TC	PI	TC	PI	TC	PI
-13	-13.4	8.71	1.11	8.51	1.15	8.27	1.18	8.14	1.20	8.03	1.22	7.74	1.26
-4	-4.4	9.67	1.19	9.46	1.23	9.19	1.27	9.04	1.29	8.92	1.31	8.59	1.34
0	-0.4	10.18	1.23	9.95	1.27	9.67	1.32	9.51	1.34	9.38	1.36	9.04	1.40
5	4.5	10.81	1.29	10.57	1.33	10.27	1.38	10.10	1.40	9.97	1.42	9.60	1.46
10	9	11.22	1.26	10.97	1.31	10.66	1.35	10.49	1.37	10.35	1.39	9.97	1.43
17	15	11.77	1.24	11.51	1.29	11.18	1.33	11.00	1.35	10.85	1.37	10.46	1.41
20	19	11.94	1.21	11.68	1.25	11.34	1.29	11.16	1.31	11.01	1.32	10.61	1.36
25	23	12.11	1.17	11.84	1.20	11.50	1.24	11.31	1.26	11.16	1.28	10.76	1.32
30	28	12.32	1.12	12.05	1.15	11.70	1.19	11.51	1.21	11.36	1.23	10.94	1.26
35	32	12.49	1.08	12.21	1.11	11.86	1.15	11.67	1.17	11.51	1.18	11.09	1.22
40	36	12.66	1.04	12.38	1.07	12.02	1.11	11.83	1.13	11.67	1.14	11.24	1.17
45	41	12.87	0.99	12.58	1.02	12.22	1.05	12.02	1.07	11.86	1.09	11.43	1.12
47	43	12.95	0.97	12.66	1.00	12.30	1.03	12.10	1.05	11.94	1.06	11.51	1.10
50	46	12.99	0.96	12.73	0.99	12.41	1.02	12.23	1.03	12.09	1.05	11.68	1.08
55	51	13.05	0.95	12.84	0.98	12.60	1.00	12.46	1.01	12.34	1.02	11.97	1.04
60	56	13.12	0.94	12.95	0.96	12.79	0.98	12.68	0.98	12.59	0.99	12.27	1.01
63	59	13.16	0.94	13.01	0.95	12.90	0.96	12.81	0.97	12.74	0.97	12.44	0.99
68	64	13.19	0.93	13.08	0.94	13.01	0.95	12.95	0.96	12.89	0.96	12.62	0.97

DB: Dry Bulb Temperature (°F) WB: Wet Bulb Temperature (°F) TC: Total Capacity (kBtu/h)
 PI: Power Input (kW) (includes compressor, indoor fan motor and outdoor fan motor)

1. All capacities are net, evaporator fan motor heat is deducted.
2. Direct interpolation is permissible. ⚠ Do not extrapolate.
3. Grey shading indicates reference data. When operating at this temperature, these values can be different if the system is not running consistently.

Capacity as rated: 0 ft. above sea level with 24.6 ft. of refrigerant piping, 0 ft. level difference between outdoor and indoor units.

Heating capacity rating obtained with air entering the indoor unit at 70°F dry bulb (DB) and 60°F wet bulb (WB), and outdoor ambient conditions of 47°F dry bulb (DB) and 43°F wet bulb (WB).

Maximum Heating Capacity Table for LC128HV (LCN128HV4 + LUU120HV)

Table 39: LCN128HV4 / LUU120HV Maximum Heating Capacities.

Outdoor Air Temp.		Indoor Air Temp. °F DB											
°F DB	°F WB	61		64		68		70		72		75	
		TC	PI	TC	PI	TC	PI	TC	PI	TC	PI	TC	PI
-13	-13.4	8.65	1.17	8.46	1.20	8.22	1.24	8.08	1.26	7.97	1.28	7.68	1.32
-4	-4.4	9.93	1.25	9.71	1.29	9.44	1.33	9.28	1.35	9.16	1.37	8.82	1.41
0	-0.4	10.61	1.30	10.37	1.34	10.08	1.38	9.91	1.40	9.78	1.42	9.42	1.47
5	4.5	11.45	1.36	11.20	1.40	10.88	1.45	10.70	1.47	10.56	1.49	10.17	1.53
10	9	12.00	1.36	11.74	1.40	11.40	1.45	11.21	1.47	11.07	1.49	10.66	1.53
17	15	12.74	1.36	12.45	1.40	12.10	1.45	11.90	1.47	11.74	1.49	11.31	1.53
20	19	13.29	1.36	12.99	1.40	12.62	1.45	12.41	1.47	12.25	1.49	11.80	1.54
25	23	13.84	1.36	13.53	1.41	13.14	1.45	12.93	1.48	12.76	1.50	12.29	1.54
30	28	14.53	1.37	14.20	1.41	13.80	1.46	13.57	1.48	13.39	1.50	12.90	1.55
35	32	15.08	1.37	14.74	1.42	14.32	1.46	14.09	1.49	13.90	1.51	13.39	1.55
40	36	15.63	1.38	15.28	1.42	14.84	1.47	14.60	1.49	14.41	1.51	13.88	1.56
45	41	16.32	1.38	15.95	1.43	15.50	1.47	15.24	1.50	15.04	1.52	14.49	1.56
47	43	16.59	1.38	16.22	1.43	15.76	1.47	15.50	1.50	15.29	1.52	14.74	1.57
50	46	16.64	1.37	16.30	1.42	15.90	1.46	15.67	1.48	15.49	1.50	14.96	1.54
55	51	16.72	1.36	16.44	1.39	16.14	1.43	15.96	1.44	15.81	1.46	15.34	1.49
60	56	16.80	1.35	16.58	1.37	16.38	1.40	16.24	1.41	16.13	1.42	15.72	1.44
63	59	16.85	1.34	16.67	1.36	16.52	1.38	16.41	1.39	16.32	1.39	15.94	1.41
68	64	16.90	1.33	16.75	1.34	16.67	1.36	16.58	1.36	16.52	1.37	16.17	1.38

DB: Dry Bulb Temperature (°F) WB: Wet Bulb Temperature (°F) TC: Total Capacity (kBtu/h)
 PI: Power Input (kW) (includes compressor, indoor fan motor and outdoor fan motor)

1. All capacities are net, evaporator fan motor heat is deducted.
2. Direct interpolation is permissible. ⚠ Do not extrapolate.
3. Grey shading indicates reference data. When operating at this temperature, these values can be different if the system is not running consistently.

Capacity as rated: 0 ft. above sea level with 24.6 ft. of refrigerant piping, 0 ft. level difference between outdoor and indoor units.

Heating capacity rating obtained with air entering the indoor unit at 70°F dry bulb (DB) and 60°F wet bulb (WB), and outdoor ambient conditions of 47°F dry bulb (DB) and 43°F wet bulb (WB).



PERFORMANCE DATA

Maximum Heating Capacity

LC188HV, LC249HV

Maximum Heating Capacity Table for LC188HV (LCN188HV4 + LUU180HV)

Table 41: LCN188HV4 / LUU180HV Maximum Heating Capacities.

Outdoor Air Temp.		Indoor Air Temp. °F DB											
°F DB	°F WB	61		64		68		70		72		75	
		TC	PI	TC	PI	TC	PI	TC	PI	TC	PI	TC	PI
-13	-13.4	15.47	2.04	15.13	2.11	14.69	2.17	14.45	2.21	14.26	2.24	13.74	2.31
-4	-4.4	16.33	2.18	15.96	2.25	15.51	2.32	15.25	2.36	15.05	2.40	14.50	2.47
0	-0.4	16.78	2.26	16.40	2.34	15.93	2.41	15.67	2.46	15.47	2.49	14.90	2.56
5	4.5	17.34	2.37	16.95	2.45	16.47	2.53	16.20	2.57	15.98	2.60	15.40	2.68
10	9	17.71	2.09	17.31	2.16	16.82	2.23	16.54	2.27	16.32	2.30	15.73	2.37
17	15	18.20	1.89	17.79	1.95	17.28	2.02	17.00	2.05	16.77	2.08	16.16	2.14
20	19	19.18	1.96	18.75	2.03	18.21	2.09	17.91	2.13	17.68	2.16	17.03	2.22
25	23	20.15	2.04	19.70	2.10	19.14	2.17	18.83	2.21	18.58	2.24	17.90	2.30
30	28	21.38	2.13	20.90	2.20	20.30	2.27	19.97	2.31	19.71	2.34	18.99	2.41
35	32	22.36	2.20	21.86	2.27	21.23	2.34	20.89	2.38	20.61	2.42	19.86	2.49
40	36	23.34	2.27	22.81	2.35	22.16	2.42	21.80	2.46	21.51	2.50	20.73	2.57
45	41	24.56	2.36	24.01	2.44	23.32	2.52	22.94	2.56	22.64	2.60	21.81	2.67
47	43	25.05	2.40	24.49	2.48	23.79	2.56	23.40	2.60	23.09	2.64	22.25	2.71
50	46	25.12	2.38	24.61	2.45	24.01	2.52	23.66	2.56	23.38	2.59	22.59	2.66
55	51	25.24	2.36	24.83	2.42	24.37	2.47	24.09	2.50	23.86	2.52	23.16	2.58
60	56	25.37	2.33	25.04	2.38	24.73	2.42	24.52	2.44	24.35	2.45	23.73	2.49
63	59	25.44	2.32	25.16	2.35	24.95	2.39	24.78	2.40	24.64	2.41	24.07	2.44
68	64	25.51	2.30	25.29	2.33	25.16	2.36	25.04	2.36	24.93	2.37	24.41	2.39

DB: Dry Bulb Temperature (°F) WB: Wet Bulb Temperature (°F) TC: Total Capacity (kBtu/h)
PI: Power Input (kW) (includes compressor, indoor fan motor and outdoor fan motor)

1. All capacities are net, evaporator fan motor heat is deducted.
2. Direct interpolation is permissible. Ⓞ Do not extrapolate.
3. Grey shading indicates reference data. When operating at this temperature, these values can be different if the system is not running consistently.

Capacity as rated: 0 ft. above sea level with 24.6 ft. of refrigerant piping, 0 ft. level difference between outdoor and indoor units.

Heating capacity rating obtained with air entering the indoor unit at 70°F dry bulb (DB) and 60°F wet bulb (WB), and outdoor ambient conditions of 47°F dry bulb (DB) and 43°F wet bulb (WB).

Maximum Heating Capacity Table for LC249HV (LCN249HV + LUU240HV)

Table 40: LCN249HV / LUU240HV Maximum Heating Capacities.

Outdoor Air Temp.		Indoor Air Temp. °F DB											
°F DB	°F WB	61		64		68		70		72		75	
		TC	PI	TC	PI	TC	PI	TC	PI	TC	PI	TC	PI
-13	-13.4	19.66	2.75	19.22	2.84	18.67	2.93	18.36	2.98	18.12	3.02	17.46	3.12
-4	-4.4	22.22	2.94	21.73	3.04	21.11	3.14	20.76	3.19	20.49	3.24	19.74	3.33
0	-0.4	23.57	3.06	23.05	3.16	22.39	3.26	22.02	3.32	21.73	3.36	20.94	3.46
5	4.5	22.69	2.77	22.19	2.86	21.55	2.95	21.20	3.00	20.92	3.04	20.16	3.13
10	9	24.90	2.70	24.34	2.79	23.64	2.88	23.26	2.93	22.95	2.97	22.11	3.06
17	15	27.83	2.66	27.21	2.74	26.43	2.83	26.00	2.88	25.65	2.92	24.72	3.01
20	19	28.44	2.70	27.81	2.79	27.01	2.88	26.57	2.93	26.22	2.97	25.26	3.05
25	23	29.05	2.74	28.41	2.83	27.59	2.92	27.14	2.97	26.78	3.01	25.81	3.10
30	28	29.82	2.79	29.15	2.88	28.32	2.98	27.86	3.03	27.49	3.07	26.49	3.16
35	32	30.43	2.83	29.75	2.93	28.90	3.02	28.43	3.07	28.05	3.12	27.03	3.21
40	36	31.04	2.88	30.35	2.97	29.48	3.07	29.00	3.12	28.61	3.16	27.57	3.26
45	41	31.81	2.93	31.10	3.03	30.21	3.12	29.71	3.18	29.32	3.22	28.25	3.32
47	43	32.11	2.95	31.40	3.05	30.50	3.15	30	3.2	29.60	3.24	28.52	3.34
50	46	32.21	2.93	31.56	3.02	30.78	3.11	30.33	3.15	29.97	3.19	28.96	3.28
55	51	32.36	2.90	31.83	2.97	31.24	3.04	30.88	3.08	30.59	3.11	29.69	3.17
60	56	32.52	2.87	32.10	2.93	31.70	2.98	31.43	3.00	31.22	3.02	30.42	3.07
63	59	32.62	2.85	32.26	2.90	31.98	2.94	31.76	2.96	31.59	2.97	30.85	3.00
68	64	32.71	2.83	32.42	2.87	32.26	2.90	32.10	2.91	31.96	2.92	31.30	2.94

DB: Dry Bulb Temperature (°F) WB: Wet Bulb Temperature (°F) TC: Total Capacity (kBtu/h)
PI: Power Input (kW) (includes compressor, indoor fan motor and outdoor fan motor)

1. All capacities are net, evaporator fan motor heat is deducted.
2. Direct interpolation is permissible. Ⓞ Do not extrapolate.
3. Grey shading indicates reference data. When operating at this temperature, these values can be different if the system is not running consistently.

Capacity as rated: 0 ft. above sea level with 24.6 ft. of refrigerant piping, 0 ft. level difference between outdoor and indoor units.

Heating capacity rating obtained with air entering the indoor unit at 70°F dry bulb (DB) and 60°F wet bulb (WB), and outdoor ambient conditions of 47°F dry bulb (DB) and 43°F wet bulb (WB).

PERFORMANCE DATA

Maximum Heating Capacity

LC369HV, LC429HV

Maximum Heating Capacity Table for LC369HV (LCN369HV + LUU360HV)

Table 42: LCN369HV / LUU360HV Maximum Heating Capacities.

Outdoor Air Temp.		Indoor Air Temp. °F DB											
°F DB	°F WB	61		64		68		70		72		75	
		TC	PI	TC	PI	TC	PI	TC	PI	TC	PI	TC	PI
-13	-13.4	30.46	4.36	29.78	4.51	28.93	4.65	28.45	4.73	28.08	4.79	27.05	4.94
-4	-4.4	33.67	4.67	32.92	4.82	31.98	4.97	31.45	5.06	31.03	5.13	29.91	5.28
0	-0.4	35.36	4.85	34.57	5.01	33.58	5.17	33.03	5.26	32.59	5.33	31.41	5.49
5	4.5	37.47	4.50	36.63	4.65	35.58	4.80	35.00	4.88	34.53	4.95	33.28	5.10
10	9	38.84	4.83	37.97	4.99	36.89	5.15	36.29	5.24	35.80	5.31	34.50	5.47
17	15	40.68	5.06	39.77	5.23	38.63	5.40	38.00	5.49	37.50	5.56	36.13	5.73
20	19	41.32	4.89	40.40	5.05	39.24	5.22	38.60	5.31	38.09	5.38	36.70	5.54
25	23	41.96	4.72	41.02	4.88	39.85	5.03	39.20	5.12	38.68	5.19	37.27	5.35
30	28	42.76	4.51	41.81	4.66	40.61	4.81	39.95	4.89	39.42	4.96	37.99	5.11
35	32	43.41	4.34	42.44	4.48	41.22	4.63	40.55	4.71	40.01	4.77	38.56	4.91
40	36	44.05	4.17	43.06	4.31	41.83	4.45	41.15	4.52	40.60	4.58	39.13	4.72
45	41	44.85	3.96	43.85	4.09	42.60	4.22	41.90	4.29	41.34	4.35	39.84	4.48
47	43	45.17	3.87	44.16	4.00	42.90	4.13	42.2	4.2	41.64	4.26	40.13	4.38
50	46	45.30	3.85	44.39	3.96	43.29	4.08	42.66	4.14	42.16	4.19	40.74	4.30
55	51	45.53	3.81	44.77	3.90	43.94	3.99	43.44	4.04	43.04	4.08	41.76	4.16
60	56	45.75	3.77	45.15	3.84	44.60	3.91	44.21	3.94	43.91	3.96	42.79	4.02
63	59	45.88	3.74	45.38	3.80	44.99	3.86	44.68	3.88	44.43	3.90	43.40	3.94
68	64	46.01	3.72	45.61	3.77	45.38	3.81	45.15	3.82	44.96	3.83	44.02	3.86

DB: Dry Bulb Temperature (°F) WB: Wet Bulb Temperature (°F) TC: Total Capacity (kBtu/h)

PI: Power Input (kW) (includes compressor, indoor fan motor and outdoor fan motor)

1. All capacities are net, evaporator fan motor heat is deducted.
2. Direct interpolation is permissible. ⊙ Do not extrapolate.
3. Grey shading indicates reference data. When operating at this temperature, these values can be different if the system is not running consistently.

Capacity as rated: 0 ft. above sea level with 24.6 ft. of refrigerant piping, 0 ft. level difference between outdoor and indoor units.

Heating capacity rating obtained with air entering the indoor unit at 70°F dry bulb (DB) and 60°F wet bulb (WB), and outdoor ambient conditions of 47°F dry bulb (DB) and 43°F wet bulb (WB).

Maximum Heating Capacity Table for LC429HV (LCN429HV + LUU420HV)

Table 43: LCN429HV / LUU420HV Maximum Heating Capacities.

Outdoor Air Temp.		Indoor Air Temp. °F DB											
°F DB	°F WB	61		64		68		70		72		75	
		TC	PI	TC	PI	TC	PI	TC	PI	TC	PI	TC	PI
-13	-13.4	39.31	4.68	38.44	4.83	37.34	4.99	36.73	5.07	36.24	5.14	34.92	5.30
-4	-4.4	40.92	5.01	40.00	5.17	38.86	5.34	38.23	5.43	37.72	5.50	36.35	5.67
0	-0.4	41.76	5.20	40.83	5.37	39.66	5.54	39.01	5.64	38.50	5.71	37.10	5.89
5	4.5	41.75	5.38	40.81	5.56	39.65	5.73	39.00	5.83	38.48	5.91	37.08	6.09
10	9	42.89	5.29	41.94	5.47	40.74	5.64	40.07	5.74	39.54	5.82	38.10	5.99
17	15	44.42	5.23	43.43	5.40	42.19	5.57	41.50	5.67	40.95	5.75	39.46	5.92
20	19	45.69	5.13	44.67	5.30	43.39	5.47	42.69	5.56	42.12	5.64	40.59	5.81
25	23	46.96	5.03	45.91	5.20	44.60	5.37	43.87	5.46	43.29	5.53	41.71	5.70
30	28	48.55	4.91	47.46	5.07	46.11	5.24	45.35	5.33	44.75	5.40	43.12	5.56
35	32	49.82	4.81	48.70	4.97	47.31	5.13	46.54	5.22	45.92	5.29	44.25	5.45
40	36	51.09	4.72	49.94	4.87	48.52	5.03	47.73	5.12	47.09	5.18	45.38	5.34
45	41	52.67	4.59	51.50	4.75	50.02	4.90	49.21	4.98	48.55	5.05	46.79	5.20
47	43	53.31	4.55	52.12	4.70	50.63	4.85	49.8	4.93	49.14	5.00	47.35	5.15
50	46	53.46	4.52	52.39	4.65	51.09	4.79	50.35	4.86	49.76	4.92	48.08	5.05
55	51	53.73	4.47	52.83	4.58	51.86	4.69	51.26	4.74	50.79	4.78	49.28	4.89
60	56	53.99	4.42	53.28	4.51	52.63	4.59	52.18	4.62	51.82	4.65	50.49	4.72
63	59	54.14	4.39	53.55	4.46	53.09	4.53	52.73	4.55	52.44	4.57	51.22	4.63
68	64	54.30	4.36	53.82	4.42	53.56	4.47	53.28	4.48	53.06	4.49	51.95	4.53

DB: Dry Bulb Temperature (°F) WB: Wet Bulb Temperature (°F) TC: Total Capacity (kBtu/h)

PI: Power Input (kW) (includes compressor, indoor fan motor and outdoor fan motor)

1. All capacities are net, evaporator fan motor heat is deducted.
2. Direct interpolation is permissible. ⊙ Do not extrapolate.
3. Grey shading indicates reference data. When operating at this temperature, these values can be different if the system is not running consistently.

Capacity as rated: 0 ft. above sea level with 24.6 ft. of refrigerant piping, 0 ft. level difference between outdoor and indoor units.

Heating capacity rating obtained with air entering the indoor unit at 70°F dry bulb (DB) and 60°F wet bulb (WB), and outdoor ambient conditions of 47°F dry bulb (DB) and 43°F wet bulb (WB).



EQUIPMENT SELECTION PROCEDURE

Correction Factors

Cooling / Heating Correction Factors

For Four-Way Ceiling Cassette systems, calculate the equivalent length of the liquid line from the outdoor unit to the indoor unit. Also, determine the elevation difference of the indoor unit above or below the outdoor unit. Find corresponding cooling or heating capacity correction factors as shown below. Multiply the correction factors by the cooling or heating capacity obtained from the capacity table using design conditions. The resultant is the NET cooling or heating capacity.

Refrigerant Line Length Derates

For air-cooled systems, a capacity correction factor will have to be applied to account for the length of the system's refrigerant pipe. Rate of change in capacity due to increased piping lengths is shown below.

Table 44: 9,000 and 12,000 Btu/h Capacity Cassette System Cooling and Heating Capacity Coefficient Factors.

Piping Length (ft.)		24.6	32.8	49.2	65.6	98.4	131.2	164.0	196.9	229.7	246.0
Cooling Capacity Coefficient Factor											
Rate of Capacity Change (%)	LC098HV (9,000 Btu/h)	100	99.7	99.2	98.7	-	-	-	-	-	-
	LC128HV (12,000 Btu/h)	100	99.7	99.2	98.7	-	-	-	-	-	-
Heating Capacity Coefficient Factor											
Rate of Capacity Change (%)	LC098HV (9,000 Btu/h)	100	99.7	99.2	98.7	-	-	-	-	-	-
	LC128HV (12,000 Btu/h)	100	99.7	99.2	98.7	-	-	-	-	-	-

Table 45: 18,000 to 42,000 Btu/h Capacity Cassette System Cooling and Heating Capacity Coefficient Factors.

Piping Length (ft.)		24.6	32.8	49.2	65.6	98.4	131.2	164	196.9	229.7	246
Cooling Capacity Coefficient Factor.											
Rate of Capacity Change (%)	LC188HV (18,000 Btu/h)	100	100	99.3	97.9	96.6	93.8	91.1	-	-	-
	LC249HV (24,000 Btu/h)	100	100	99.3	97.9	96.6	93.8	91.1	-	-	-
	LC369HV (36,000 Btu/h)	100	100	99.3	97.9	96.6	93.8	91.1	88.4	85.6	82.9
	LC429HV (42,000 Btu/h)	100	100	99.3	97.9	96.6	93.8	91.1	88.4	85.6	82.9
Heating Capacity Coefficient Factor.											
Rate of Capacity Change (%)	LC188HV (18,000 Btu/h)	100	99.3	97.9	96.6	9.8	91.1	88.4	-	-	-
	LC249HV (24,000 Btu/h)	100	99.3	97.9	96.6	9.8	91.1	88.4	-	-	-
	LC369HV (36,000 Btu/h)	100	99.7	99.2	98.7	97.7	96.6	95.6	94.6	93.5	93.0
	LC429HV (42,000 Btu/h)	100	99.7	99.2	98.7	97.7	96.6	95.6	94.6	93.5	93.0

Equivalent Piping Length for Piping Components

Table 46: Equivalent Piping Length for Elbows.

Component	Size (Inches)													
	1/4	3/8	1/2	5/8	3/4	7/8	1	1-1/8	1-1/4	1-3/8	1-1/2	1-5/8	1-3/4	2-1/8
Elbow (ft.)	0.5	0.6	0.7	0.8	1.2	1.3	1.5	1.6	1.8	2.0	2.1	2.3	2.5	2.8

Altitude Correction Factor

The impact of air density must be considered on systems installed at a significant altitude above sea level, therefore, locally accepted altitude correction factors must be applied.

EQUIPMENT SELECTION PROCEDURE

Defrost Correction Factor for Heating Operation

The outdoor unit heating capacity will need to be adjusted for frost accumulation on air-cooled systems. If design day conditions are below the dewpoint of the surrounding air, frost will not be a problem and no correction factor is needed. In certain weather conditions, however, frost will form and accumulate on the air-cooled outdoor unit coil and impact the coils ability to transfer heat. If significant frost accumulates on the outdoor unit coil, a defrost algorithm will start automatically. The timing between defrost periods is determined by the system's ability to achieve a target head pressure value.

Capacity and AHRI ratings tables do not factor in capacity reduction when frost has accumulated on the condenser coil, nor during defrost operation.

Integrated heating capacity values can be obtained using the formula: **Table 47: Outdoor Unit Frost Accumulation Factor (Heating)¹.**

$$A = B \times C$$

Where:

A = Integrated Heating Capacity.

B = Value found in the Capacity Table.

C = Correction Factor for Frost Accumulation Factor (from table at right).

Entering DB (°F)	19.4	23.0	26.6	32.0	37.4	41.0	44.6
Derate factor	0.98	0.95	0.93	0.86	0.93	0.96	1.0

¹At 85% outdoor air relative humidity.

The frost accumulation factor does not account for effects of snow accumulation restricting airflow through the outdoor unit coil.

Note:

There will be a temporary reduction in capacity when frost / ice accumulates on the outside surface of the outdoor unit heat exchanger. The level of capacity reduction depends on a number of factors, for example, outdoor temperature (°F DB), relative humidity (RH), and the amount of frost present.

Check the Indoor and Outdoor Unit Selection(s)

Compare the corrected cooling and heating capacities to the load calculations. Is each capacity sufficient for the zone it serves?

For each indoor unit, the corrected capacity must be at least equal to the total of the cooling design load (plus ventilation load, if applicable) for the space(s) served by the indoor unit. For each indoor unit, the corrected capacity also must be at least equal to the total of the heating design load (plus ventilation load, if applicable) for the space(s) and / or thermal zones served by the indoor unit.

The outdoor unit selected must be large enough to offset the total cooling load for all spaces it serves (account for ventilation air cooling load if the ventilation air has not been pretreated to room neutral conditions). The outdoor unit must also be large enough to offset the total heating load for all spaces it serves.

If the corrected heating capacity ratio exceeds 100%, reselect the equipment, or change the system design by moving some of the load to another system.

System Sizing Check Formulas

1. Outdoor Unit Rated Capacity.

$Q_{odu(rated)}$ (From capacity tables).

2. Outdoor Unit Capacity at T_i , T_o Temperature.

$Q_{odu(T_i, T_o)}$ (From capacity tables).

3. Outdoor Unit Capacity Coefficient Factor.

$F_{(T_i, T_o)} = Q_{odu(T_i, T_o)} / Q_{odu(rated)}$

4. Piping Correction Factor (From Capacity Coefficient Factor Tables).

$F_{(length)}$ for each piping length

5. Individual Indoor Unit Combination Capacity.

$Q_{idu(combi)} = Q_{odu(rated)} \times Q_{idu(rated)} / Q_{idu(rated-total)}$

6. Individual Indoor Unit Actual Capacity.

$Q_{idu(actual)} = Q_{odu(combi)} \times F_{(T_i, T_o)} \times F_{(length, altitude)}$

Conclusions and Recommendations

- Understand the design safety factors.
- Reference load calculations for actual cooling and heating capacities (applies in 99% of applications – consider total load when latent load is greater than 30%).
- Verify that the sensible load of the zone is satisfied.
- Use caution when sizing to meet listed capacity specifications for the scheduled manufacturer's equipment.

If further system design assistance is needed, or you have a unique application you would like to discuss, contact your LG sales rep.



APPLICATION GUIDELINES

Placement Considerations on page 67

Installing Outdoor Units Indoors on page 75

Refrigerant Piping Design on page 78

PLACEMENT CONSIDERATIONS

Indoor Unit

Selecting the Best Location for the Indoor Unit

⚠ WARNING

The unit should not be installed where sulfuric acid and flammable or corrosive gases are generated, vented into, or stored. There is risk of fire, explosion, and physical injury or death.

Note:

Do's

Select a location for installing the indoor units that will meet the following conditions:

- Place the unit where air circulation will not be blocked.
- Locate the indoor unit in a location that is level, and where it can be easily connected to the outdoor unit.
- Place the unit in a location where condensation drainage can be conveniently routed away.
- Include enough space around the indoor unit so that it is accessible for maintenance and service purposes.
- Place the unit in a location where electrical noise / electromagnetic waves will not impact operation. Maintain proper distances between the indoor units and electric wires, audio and visual appliances, breaker / circuit panels, etc.
- Place in an area that is level and with enough strength to bear the weight of the indoor unit(s).

Figure 43: Indoor Unit Clearance Requirements.

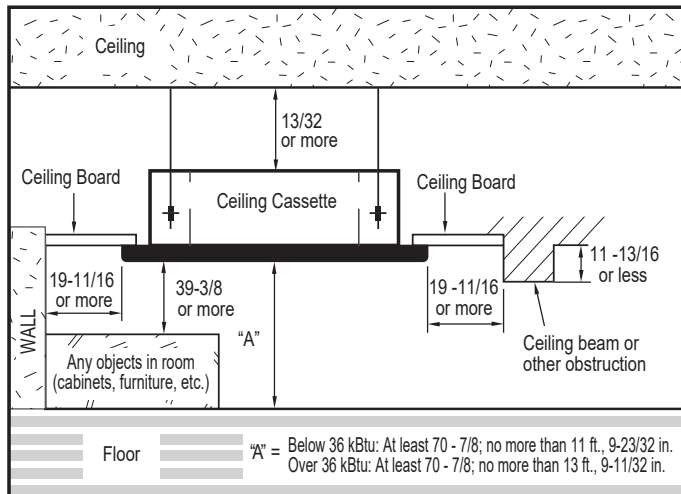

Unit: Inch

⊘ Do Not's

- No obstacles to air circulation around the unit; keep proper distances from ceilings, doorways, floor, walls, etc.
- The unit should not be installed near a heat or steam source, or where considerable amounts of oil, iron powder, or flour are used.
- The unit should not be installed where sulfuric acid and flammable or corrosive gases are generated, vented into, or stored.
- Avoid installing the unit near high-frequency generators or near any equipment that generates an electromagnetic field (minimum 3-1/3 feet away).

Figure 44: 2 x 2 Cassette Ceiling Opening Dimensions and Bolt Locations.

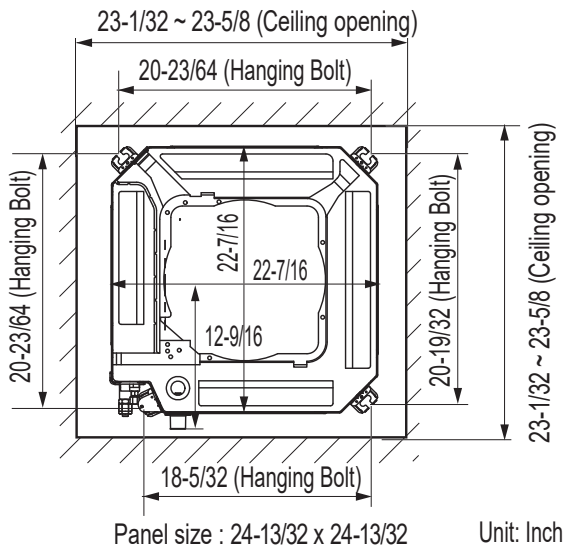

Unit: Inch

Figure 45: 3 x 3 Cassette Ceiling Opening Dimensions and Bolt Locations.

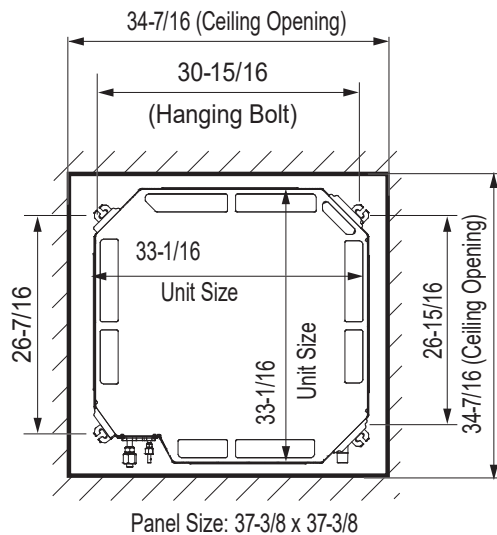

Panel Size: 37-3/8 x 37-3/8

Unit: Inch

PLACEMENT CONSIDERATIONS

Indoor Unit

NOTE

- Indoor units (IDUs) should not be placed in an environment where the IDUs will be exposed to harmful volatile organic compounds (VOCs) or in environments where there is improper air make up or supply or inadequate ventilation. If there are concerns about VOCs in the environment where the IDUs are installed, proper air make up or supply and / or adequate ventilation should be provided. Additionally, in buildings where IDUs will be exposed to VOCs consider a factory-applied epoxy coating to the fan coils for each IDU.
- If the unit is installed near a body of water, certain components are at risk of being corroded. Appropriate anti-corrosion methods should be taken for the unit and all components.

The unit will be damaged, will malfunction, and / or will not operate as designed if installed in any of the conditions listed.

Installing in a High or Dropped Ceiling

High or dropped ceilings, often found in commercial buildings and offices, will cause a wide temperature differentiation. To countermeasure:

- Change the indoor unit mode selection to allow for higher ceilings (see table).
- Install an air circulator.
- Set the air discharge outlet so that heated air flows in a downward direction.
- Use a dual door system to protect the building gate or exit.

Table 48: Indoor Unit High Ceiling Mode Selection Options (LCN098HV, LCN128HV, LCN188HV).

Ceiling Height	Mode Selection
≤7-1/2 feet	Low Ceiling
7-1/2 feet to 8-7/8 feet	Standard
8-7/8 feet to 10-3/16 feet	High Ceiling
10-3/16 feet to 11-13/16 feet	Very High Ceiling

Table 49: Indoor Unit High Ceiling Mode Selection Options (LCN249HV, LCN369HV, LCN429HV).

Ceiling Height	Mode Selection
≤8-7/8 feet	Low Ceiling
8-7/8 feet to 10-1/2 feet	Standard
10-1/2 feet to 11-13/16 feet	High Ceiling
11-13/16 feet to 13-13/16 feet	Very High Ceiling

Installing in an Area Exposed to Unconditioned Air

In some installation applications, areas (floors, walls) in some rooms will be exposed to unconditioned air (room will be above or next to an unheated garage or storeroom). To countermeasure:

- Verify that carpet is or will be installed (carpet will increase the temperature by three degrees).
- Add insulation between the floor joists.
- Install radiant heat or another type of heating system to the floor.

Installing in an Area with High Humidity Levels

If the environment is prone to humidity levels of 80% or more (near the ocean, lakes, etc.) or where steam could collect in the plenum:



- Install additional insulation to the indoor unit (glass wool insulation >13/32 inches thick).
- Install additional insulation to the refrigerant piping (insulation >13/16 inches thick).
- Seal all gaps between the indoor unit and the ceiling tiles (make the area air tight) so that humidity does not transfer from the plenum to the conditioned space. Also, add a ceiling grille for ventilation.

PLACEMENT CONSIDERATIONS

Outdoor Unit

Selecting the Best Location for the Outdoor Unit

⚠ DANGER

-  Do not install the unit in an area where combustible gas will generate, flow, stagnate, or leak. These conditions can cause a fire, resulting in bodily injury or death.
-  Do not install the unit in a location where acidic solution and spray (sulfur) are often used as it can cause bodily injury or death.
-  Do not use the unit in environments where oil, steam, or sulfuric gas are present as it can cause bodily injury or death.

⚠ CAUTION

When deciding on a location to place the outdoor unit, be sure to choose an area where run-off from defrost will not accumulate and freeze on sidewalks or driveways, which will create unsafe conditions. Properly install and insulate any drain hoses to prevent the hose from freezing, cracking, leaking, and causing unsafe conditions from frozen condensate.

⚠ WARNING

Install a fence to prevent vermin from crawling into the unit or unauthorized individuals from accessing it. Vermin and unauthorized individuals will cause a fire, electric shock, physical injury or death. Follow the placement guidelines set forth in "Clearance Requirements".

⚠ NOTE

Install a fence to prevent vermin from crawling into the unit or unauthorized individuals from accessing it. Vermin and unauthorized individuals will damage the unit. Follow the placement guidelines set forth in "Clearance Requirements".

Select a location for installing the outdoor unit that will meet the following conditions:

- Where there is enough strength to bear the weight of the unit.
- A location that allows for optimum air flow and is easily accessible for inspection, maintenance, and service.
- Where piping between the outdoor unit and indoor unit is within allowable limits.
- Include space for drainage to ensure condensate flows properly out of the unit when it is in heating mode.  Avoid placing the outdoor unit in a low-lying area where water could accumulate.
- If the outdoor unit is installed in a highly humid environment (near an ocean, lake, etc.), ensure that the site is well-ventilated and has a lot of natural light (Example: Install on a rooftop).

Do Not's

- Where it will be subjected to direct thermal radiation from other heat sources, or an area that would expose the outdoor unit to heat or steam like discharge from boiler stacks, chimneys, steam relief ports, other air conditioning units, kitchen vents, plumbing vents, and other sources of extreme temperatures.
- Where high-frequency electrical noise / electromagnetic waves will affect operation.
- Where operating sound from the unit will disturb inhabitants of surrounding buildings.
- Where the unit will be exposed to direct, strong winds.
- Where the discharge of one outdoor unit will blow into the inlet side of an adjacent unit (when installing multiple outdoor units).

Outdoor Unit Condensate Drain Piping

Outdoor unit requires condensate drain piping. Condensate drain pipe is constructed with materials approved by local code. See pages 72-74 for information in reference to outdoor unit placement.

PLACEMENT CONSIDERATIONS

Outdoor Unit

Planning for Snow and Ice

To ensure the outdoor unit operates properly, certain measures are required in locations where there is a possibility of heavy snowfall or severe windchill or cold:

1. Prepare for severe winter wind chills and heavy snowfall, even in areas of the country where these are unusual phenomena.
2. Position the outdoor unit so that its airflow fans are not buried by direct, heavy snowfall. If snow piles up and blocks the airflow, the system will malfunction.
3. Remove any snow that has accumulated four (4) inches or more on the top of the outdoor unit.
4. In climates that will experience significant snow buildup, mount the outdoor unit on a raised, field-provided platform or stand. The raised support platform must be high enough to allow the unit to remain above possible snow drifts, and must be higher than the maximum anticipated snowfall for the location.
5. Design the mounting base to prevent snow accumulation on the platform in front or back of the unit frame.
6. Provide a field fabricated snow protection hood to keep snow and ice and/or drifting snow from accumulating on the coil surfaces.
7. To prevent snow and heavy rain from entering the outdoor unit, install the condenser air inlets and outlets facing away from direct winds.
8. Consider tie-down requirements in case of high winds or where required by local codes.

⚠ CAUTION

When deciding on a location to place the outdoor unit, be sure to choose an area where run-off from defrost will not accumulate and freeze on sidewalks or driveways, which will create unsafe conditions. Properly install and insulate any drain hoses to prevent the hose from freezing, cracking, leaking, and causing unsafe conditions from frozen condensate.

Tie-Downs and Lightning Protection

Tie-Downs

- The strength of the roof must be checked before installing the outdoor units.
- If the installation site is prone to high winds or earthquakes, when installing on the wall or roof, securely anchor the mounting base using a field-provided tie-down configuration approved by a local professional engineer.
- The overall tie-down configuration must be approved by a local professional engineer.

Note:

Always refer to local code when using a wind restraint system.

Lightning Protection

- To protect the outdoor unit from lightning, it must be placed within the specified lightning safety zone.

Table 50: Safety Zone Specifications.

Building Height (feet)	66	98	148	197
Protection Angle (°)	55	45	35	25

- Power cable and communication cable must be installed five (5) feet away from lightning rod.
- A high-resistance ground system must be included to protect against induced lightning or indirect strike.

⚠ NOTE

If the building does not include lightning protection, the outdoor unit will be damaged from a lightning strike. Inform the customer of this possibility in advance.

Figure 46: Lightning Protection Diagram.

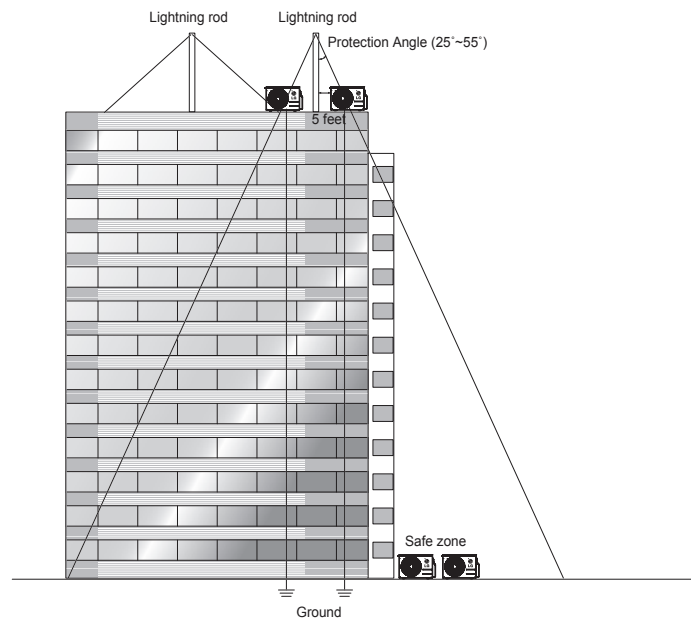

PLACEMENT CONSIDERATIONS

Outdoor Unit

Oceanside Applications

Use of a Windbreak to Shield from Sea Wind

Note:

Ocean winds will cause corrosion, particularly on the condenser and evaporator fins, which, in turn could cause product malfunction or inefficient performance.

- Avoid installing the outdoor unit where it would be directly exposed to ocean winds.
- Install the outdoor unit on the side of the building opposite from direct ocean winds.
- Select a location with good drainage.
- Periodically clean dust or salt particles off of the heat exchanger with water.
- If the outdoor unit must be placed in a location where it would be subjected to direct ocean winds, install a concrete windbreak strong enough to block any winds.
- Windbreak must be more than 150% of the outdoor unit's height. There must be 14 to 24 inches of clearance between the outdoor unit and the windbreaker for purposes of air flow.

Use of a Building to Shield from Sea Wind

If a windbreak is not possible, a building or larger structure must be used to shield the outdoor unit from direct exposure to the sea wind. The unit must be placed on the side of the building directly opposite to the direction of the wind as shown in the figure at right.

Figure 47: Oceanside Placement Using Windbreak.

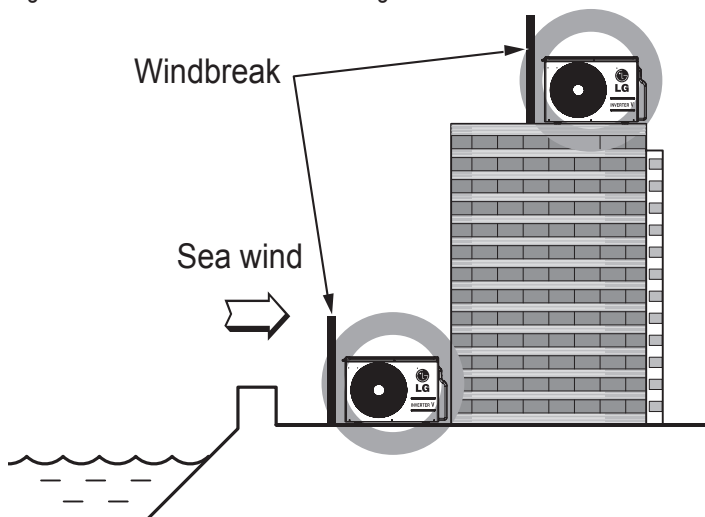

Note:

Additional anti-corrosion treatment will need to be applied to the outdoor unit at oceanside locations.

Figure 48: Placement Using Building as Shield.

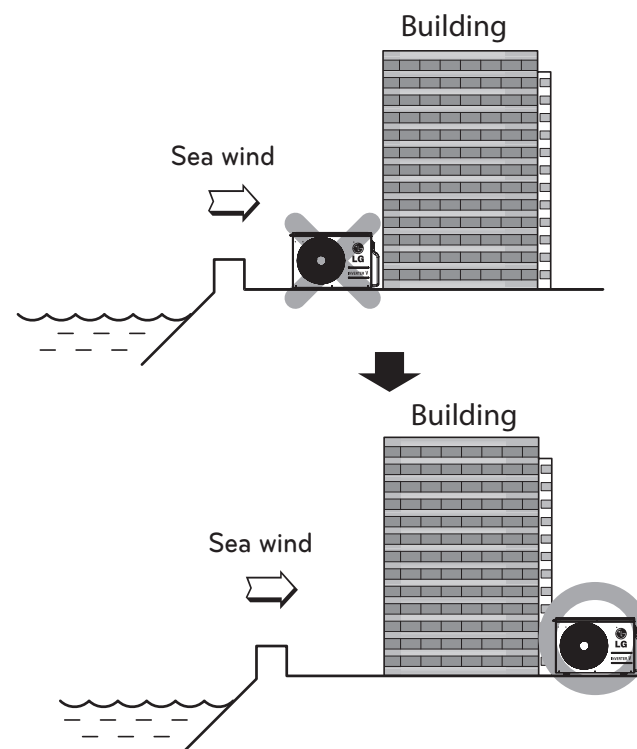

PLACEMENT CONSIDERATIONS

Outdoor Unit

Minimum Allowable Clearance and Service Access Requirements

Proper clearance for the outdoor unit coil is critical for proper unit operation. When installing the outdoor unit, consider service, inlet and outlet and minimum allowable space requirements as illustrated in the diagrams on the following pages.

- Include enough space for airflow and for service access. If installing multiple outdoor units, ⚠ avoid placing the units where the discharge of one unit will blow into the inlet side of an adjacent unit.
- If an awning is built over the unit to prevent direct sunlight or rain exposure, make sure that the discharge air of the outdoor unit isn't restricted.
- ⚠ No obstacles to air circulation around the unit; keep proper distances from ceilings, fences, floor, walls, etc. (Install a fence to prevent pests from damaging the unit or unauthorized individuals from accessing it.)

Outdoor Unit (9,000 to 24,000 Capacity) Service Access and Allowable Clearances

Specific clearance requirements in the diagram below are for (9,000 to 24,000 Btu/h capacities). The figure below shows the overall minimum clearances that must be observed for safe operation and adequate airflow around the outdoor unit.

When placing the outdoor unit under an overhang, awning, sunroof or other "roof-like structure", observe the clearance requirements (as shown in Cases 1 and 2) for height in relation to the unit. To have successful service access to the outdoor unit, see the figure below for minimum spacing. When installing multiple outdoor units, see Cases 4 and 5 for correct spacing requirements.

Note:

If the outdoor unit is installed between standard and minimum clearances, capacity decreases approximately 10%.

Figure 49: 9,000 to 24,000 Capacity Outdoor Unit Service Access and Allowable Clearances Diagram.

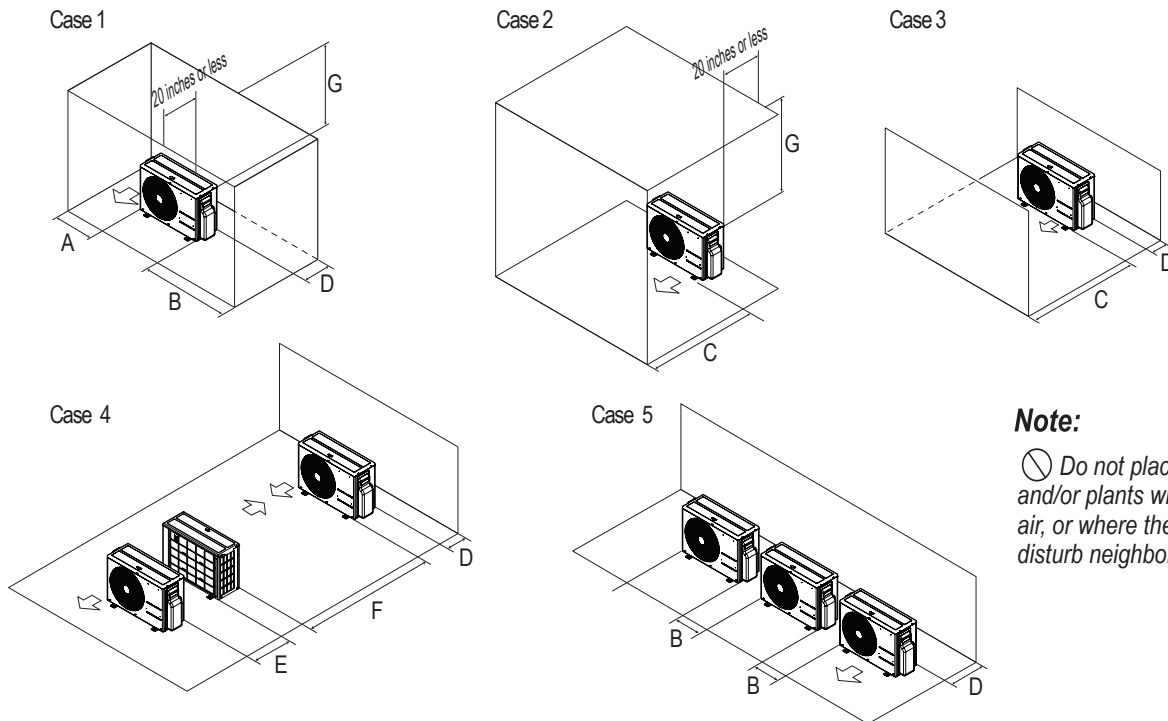

Note:

⚠ Do not place the unit where animals and/or plants will be in the path of the warm air, or where the warm air and/or noise will disturb neighbors.

Table 51: 9,000 to 24,000 Outdoor Unit Service Access and Allowable Clearances Diagram Legend.

Unit: Inch		A	B	C	D	E	F	G
Case 1	Standard	12	24	-	12	-	-	-
	Minimum	4	10	-	4	-	-	40
Case 2	Standard	-	-	20	-	-	-	-
	Minimum	-	-	14	-	-	-	40
Case 3	Standard	-	-	20	12	-	-	-
	Minimum	-	-	14	4	-	-	-
Case 4	Standard	-	-	-	12	24	-	-
	Minimum	-	-	-	4	8	79	-
Case 5	Standard	-	24	-	12	-	-	-
	Minimum	-	10	-	4	-	-	-

PLACEMENT CONSIDERATIONS

Outdoor Unit

Outdoor Unit (36,000 and 42,000 Btu/h Capacity) Service Access and Allowable Clearances

When installing the outdoor unit, consider service, inlet, and outlet, and minimum allowable space requirements as illustrated in the following diagrams.

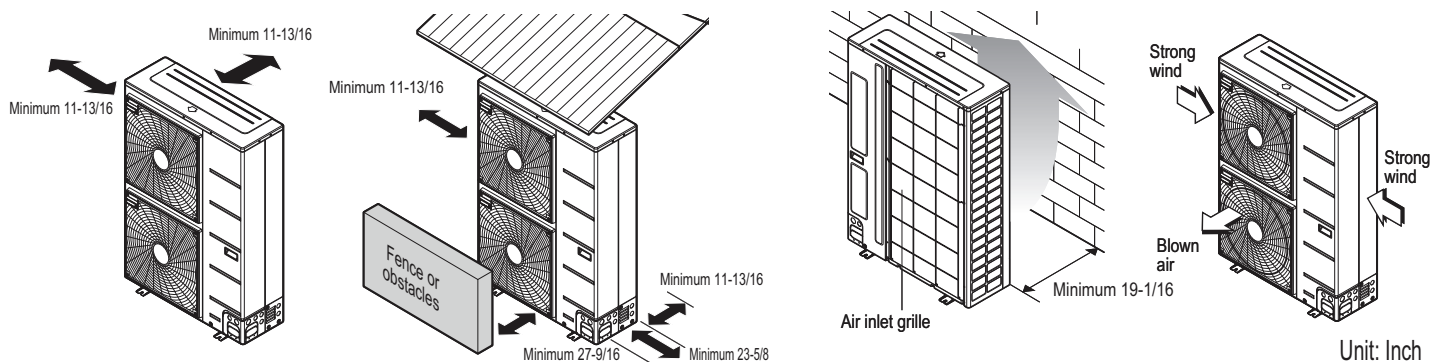

Ensure that the space at the back of the outdoor unit is a minimum of 11-13/16 inches, and include a minimum of 23-5/8 inches at the right side of the unit for service.

If the outdoor unit discharge side faces a wall, include a minimum of 19-11/16 inches between the outdoor unit and the wall. Install the outdoor unit so that the discharge port is set at a right angle to the wind direction.

Clearance Requirements when Different Obstacles are Present (Unit: Inch).

Obstacle on the suction side only.

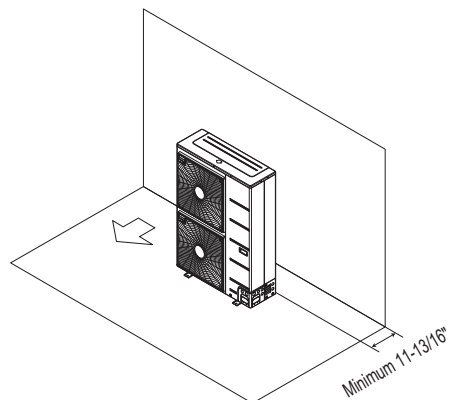

Obstacles on the suction side and on both left and right sides.

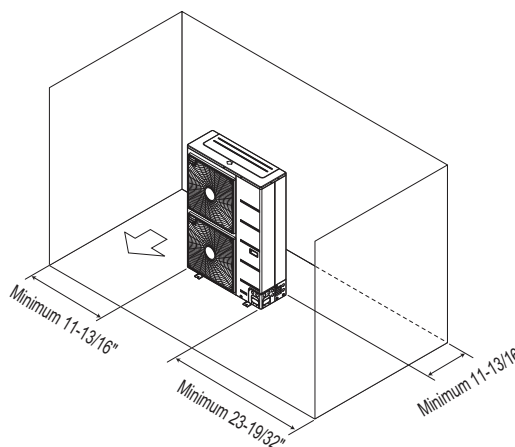

Obstacles above and on the air intake side. Obstacles above, on the air intake side, and on both left and right sides

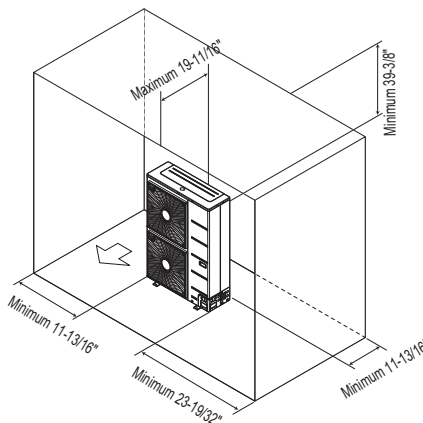
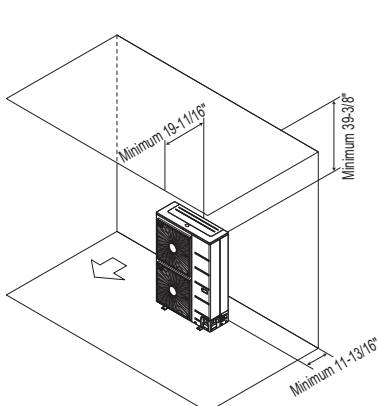

PLACEMENT CONSIDERATIONS

Outdoor Unit

Obstacle just on the air discharge side.

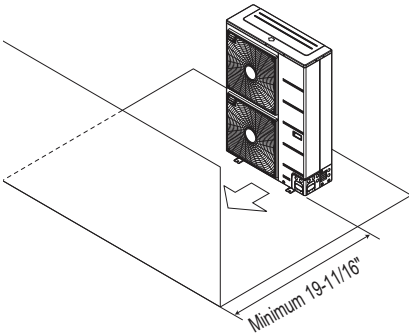

Obstacles above and on the air discharge side.

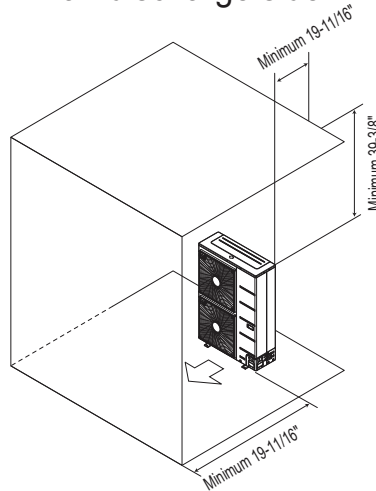

Where there are obstacles on both suction and discharge sides (discharge side obstacle is higher than the outdoor unit).

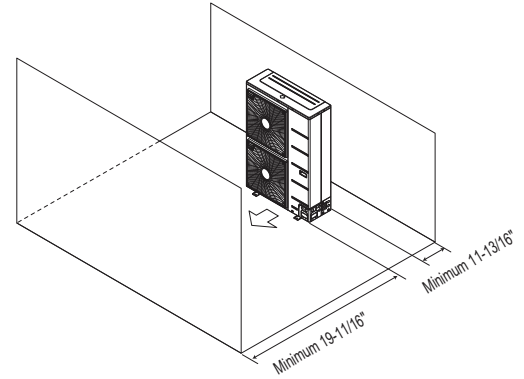

Where there are obstacles above, and on both suction and discharge sides (discharge side obstacle is higher than the outdoor unit).

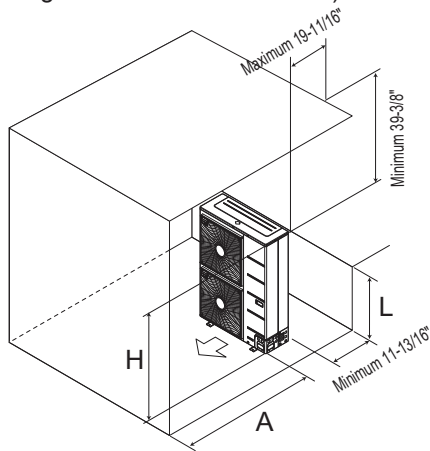
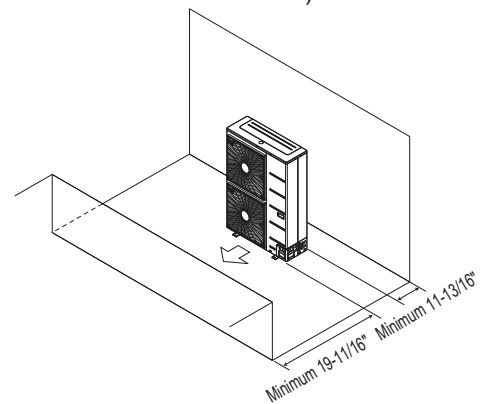

Table 52: Ratio among H, A, and L.

	L	A
$L \leq H$	$0 < L \leq 1/2 H$	29-1/32 inches
	$1/2 H < L$	39-3/8 inches
$H < L$	Set Stand as: $L \leq H$	

If a stand is necessary, it should be contained (not open frame) to prevent the discharge air from short cycling.

Where there are obstacles on both suction and discharge sides (discharge side obstacle is lower than the outdoor unit).



Where there are obstacles above, and on both suction and discharge sides (discharge side obstacle is lower than the outdoor unit).

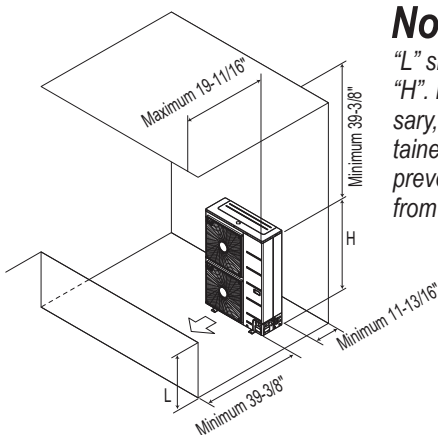

Note:

"L" should be lower than "H". If a stand is necessary, it should be contained (not open frame) to prevent the discharge air from short cycling.

Series installation

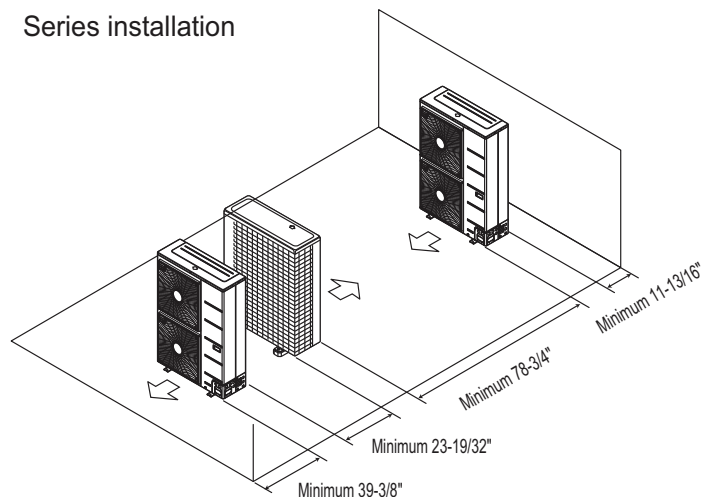

PLACEMENT CONSIDERATIONS

Installing Outdoor Units Indoors

Installing Outdoor Units Indoors

Single Zone Cassette outdoor units are engineered to be mounted outdoors and include technology designed to minimize the negative effects of winter weather's freezing rain, sleet, and snow. Some building projects, however, necessitate placing the HVAC outdoor units indoors:

- Lack of ground space.
- Lack of an appropriate outdoor location that meets system design requirements.
- When mounting on the roof is not an option due to a lack of roof space.
- Roof warranty will be voided if mechanical equipment is placed on the membrane.
- On retrofit projects, a former chiller / boiler / air handler equipment room, mechanical area, or penthouse already exists.
- To curtail the potential need for redundant zone heating devices such as wall-fin radiators or duct heaters.
- In extremely cold environments where there is a significant amount of run-time at temperatures well below freezing outside the outdoor unit ambient air temperature range published in this engineering manual.

Benefits of Installing Outdoor Units Indoors

- Shelters the outdoor unit from direct exposure to prevailing winds that decrease the heating capability of the outdoor unit.
- Protects equipment from freezing precipitation and / or potential ice build-up that could hinder unit operation.
- Maintains coil heat transfer efficiency by reducing the number of and shortening the cycle time for defrost operation.
- Easier maintenance and servicing during inclement weather.
- When mounted in a fully enclosed space, limiting the ambient air temperature will allow the Single Zone Cassette system designer to eliminate oversizing.
- The outdoor unit to compensate for loss of capacity at low ambient temperatures.
- Will also curtail the need to provide inefficient redundant zone heating devices such as wall-fin radiators and second-stage ancillary heating devices.

Design Considerations Include:

- Enclosure types and elements such as louvers (see next page), rain hoods, dampers and controls, heating methods and sizing of heating devices.
- Heating strategies.
- Duct design.
- Condensate handling.

General Guidelines

- Follow ASHRAE 62.1 design guidelines.
- Depending on the project / application, a roof over the outdoor units in combination with a wind break will be all that is necessary.
- Consider the potential for snow accumulation near louvers / roof openings. Outside air intakes and discharge ducts/louvers must be engineered to clear anticipated snow accumulation levels by at least one (1) foot.
- In situations where operation is anticipated at temperatures lower than the product's minimum operating temperature, ancillary heat must be provided to heat the outdoor unit coils to ensure continuous compressor operation and heating.

It will be necessary to use a field-fabricated air guide to prevent discharge air from short-cycling back to the coil inlet.

- Consider the direction of prevailing winds and opening placement. If possible, locate inlet openings upwind of discharge openings and other exhaust outlets.
- When inlet and outlet openings are placed on the same wall, minimum distance between the two openings must be approximately three (3) feet (minimum distance varies significantly with variations in outlet opening face velocity).
- If roof-mounted ventilation openings are used, strategically locate the inlet ventilation opening(s) upwind of the outlet opening(s).
- Discharge and supply ductwork must be designed to avoid weather related long periods of water entrainment.

PLACEMENT CONSIDERATIONS

Installing Outdoor Units Indoors

Provide a means to drain the condensate generated during heating mode and defrost cycle in addition to rainwater that infiltrates the inlet louver enclosed area.

- Install a field-provided drain pan under the outdoor units and provide a path to a nearby floor drain.
- If the ambient air temperature is expected to drop below 32°F in the enclosure, heat the bottom surface of the pan, drain line, and floor drain so that the condensate does not freeze before reaching the drain.

⚠ CAUTION

When deciding on a location to place the outdoor unit, be sure to choose an area where run-off from defrost will not accumulate and freeze on sidewalks or driveways which will create unsafe conditions.

Allow for ventilation intake and exhaust air based on maximum outdoor unit fan capacity.

- Select the size, type and orientation of architectural louvers with adequate “net free area” face velocity to ensure the total external static pressure from the outdoor unit fan does not exceed design limitations (see specification data tables).
- No obstructions must be placed in front of the louver that could hamper the free flow (throw) of air.
- Roof top openings and / or discharge and supply louvers must be equipped with screens to prevent bird and insect infiltration.

Note:

For louver recommendations, see below and on the next page.

As always, the best solution for each project balances acceptable heating performance (considering local weather conditions), capital costs, life cycle energy consumption, and limitations set forth by local building codes.

Louver Recommendations for Outdoor Unit Enclosure

1. Outdoor Unit Enclosure: Manual Door Open Type.
2. Louver Angle: No More Than 15° Horizontally.
3. Space Between Louvers: More than 4 inches (Recommend).
4. Louver Shape: Wing or Plane Type.

Note:

- Open Rate and Inlet must be taken into consideration when designing the louvered outdoor unit enclosure.
- Do not use “S” type louvers.

Note:

If the Louver Open Rate is Too Small

1. Noise can occur because of the increased air velocity passing through the louver blade.
2. Noise can occur from louver blade vibrations.
3. A drop in outdoor unit fan performance (excess static pressure can cause a drop in outdoor unit performance and heat exchanger efficiency).
4. If the louver open rate is too small or there is insufficient air flow exchange, the air conditioner might stop operating.

Figure 50: Louver Recommendations.

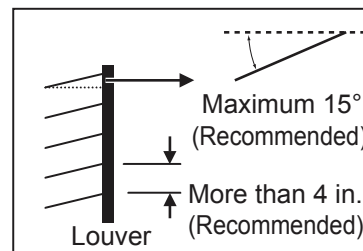
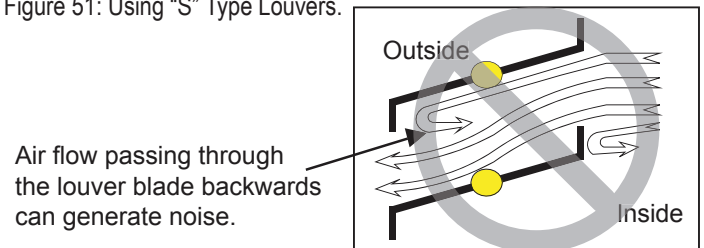

Figure 51: Using “S” Type Louvers.



PLACEMENT CONSIDERATIONS

Installing Outdoor Units Indoors

Open Rate by Louver Radian

Figure 52: Open Rate by Louver Radian Formula.

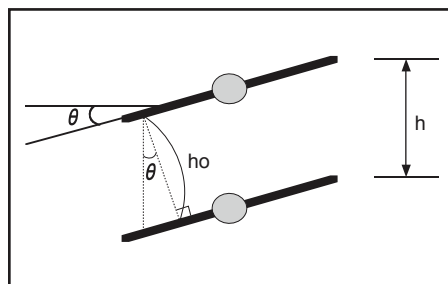

$$\theta \leq 15$$

$$h_o = h * \cos \theta$$

$$\text{Total Area (A)} = H * W$$

$$\text{Number of Open Spaces (N)} = (\text{Number of Louvers} - 1)$$

$$\text{Effective Area (Af)} = h_o * W * N$$

$$\text{Louver Open Rate (n)} = \text{Af} / A$$

$$\therefore \text{Af} = A * n$$

Effective Cross Section Area

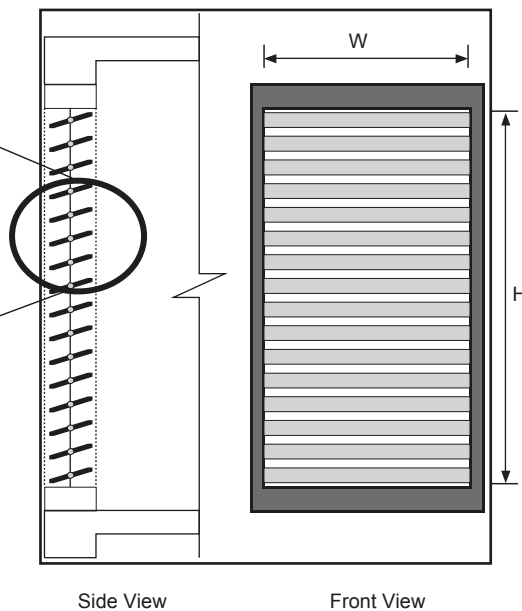

Confirming Air Flow Rate / Total Opening Rate

- Example: LSU180HSV5 (For illustrative purposes only).

- Discharge Airflow Rate: 2,119 ft.³/min.

- Velocity of Outlet Air: 16.4 ft./s

- Velocity of Inlet Air: 8.2 ft./s

- Open Rate = 80% or More
- Open Rate = $\frac{\text{Effective Face Area (Af)}}{\text{Total Face Area (A)}}$

- Inlet airflow must match or exceed discharge airflow.
- Separate inlet airflow from discharge airflow to prevent recirculation.

Formula

- Total Louver Dimension (Excluding Frame) (A) = 3.9 feet x 6.2 feet = 24.2 ft.²
- Area Blocked by Outdoor Unit (Discharge) (B) = 2.6 feet x 2.8 feet = 7.41 ft.²
- Inlet Louver Dimension (A - B) = 16.8 ft.²
- Equivalent Inlet Dimension (Open Rate 80%) = 16.8 ft.² x 0.8 = 13.44 ft.²
- Equivalent Inlet Airflow = 13.44 ft.² x 8.2 ft./s x 60 sec./min. = 6,612 ft.³/min.
- Equivalent Inlet Airflow / Discharge Airflow = 6,612 ft.³/min. / 2,119 ft.³/min. = 312% (Within Allowable Limits)

Figure 53: Example of Installing Outdoor Unit Indoors.

Louver Dimensions

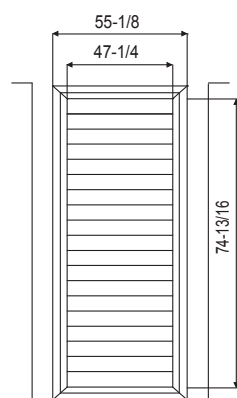

Unit: Inch

Air Guide Duct on Outdoor Unit

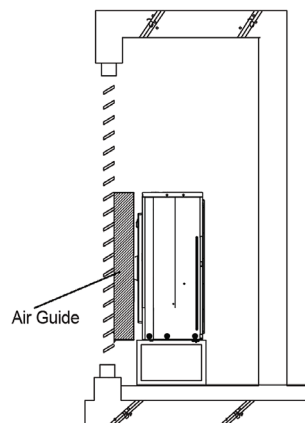

Outdoor Unit Dimensions

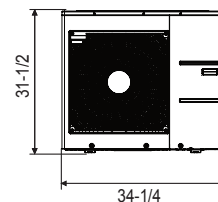

REFRIGERANT PIPING DESIGN

Device Connection Limitations

A single-zone system consists of one outdoor unit and one indoor unit. One of the most critical elements of a single-zone system is the refrigerant piping. If the connection piping is not within allowable limits, there will be reliability, performance, noise, and vibration issues. The table below lists pipe length limits that must be followed in the design of a Single Zone Four-Way Ceiling-Cassette refrigerant pipe system. See paragraph below for calculating additional refrigerant charge necessary for longer piping lengths. Refer to the figures for maximum length and elevation of piping.

Table 53: Single-Zone Four-Way Ceiling Cassette Refrigerant Piping System Limitations.

System Model Name		LC098HV, LC128HV	LC188HV, LC249HV	LC369HV, LC429HV
Pipe Sizes	Vapor	3/8	5/8	5/8
	Liquid	1/4	3/8	3/8
Pipe Length (ELF = Equivalent Length of Pipe)	Standard length (no add'l refrigerant)	24.6 feet	24.6 feet	24.6 feet
	Longest total equivalent piping length	66 feet	164 feet	246 feet
	Shortest total equivalent piping length	16.4	16.4	16.4
	Distance between fittings and indoor or outdoor units	≥20 inches	≥20 inches	≥20 inches
Elevation (All Elevation Limitations are Measured in Actual Feet)	If outdoor unit is above indoor unit	49 feet	98.4 feet	98.4 feet
	If outdoor unit is below indoor unit	49 feet	98.4 feet	98.4 feet
Additional Refrigerant Needed (oz/ft)		0.22	0.43	0.43

Figure 54: Typical LC098HV and LC128HV System Layout.

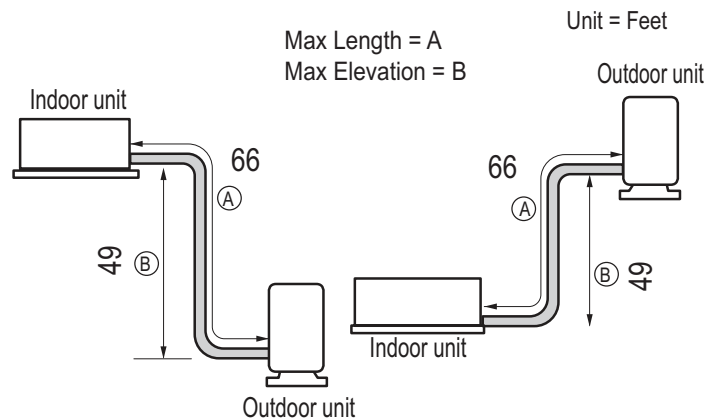
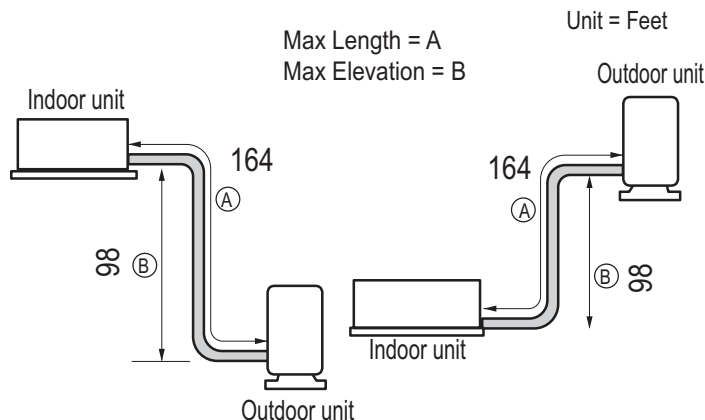

Figure 55: Typical LC188HV and LC249HV System Layout.



Additional Refrigerant Charge

Each outdoor unit is factory charged (nameplate charge) for the evaporator as well as a standard 24.6 foot line. Any time a line set is used longer than the standard 24.6 foot line set length, the refrigerant charge has to be adjusted.

The charge must be adjusted on 0.22 oz. or 0.43 oz. of R410A per foot based on how many feet of piping are added. The factory charge accommodates pipe lengths up to the standard length without requiring refrigerant removal.

NOTE

If the unit charge is unknown, reclaim, evacuate and weigh in the correct charge using the unit nameplate (capacity) charge adjusting for line sets longer than 24.6 ft. This will prevent any interruptions to the functioning of the unit and possible damage.

Example:

A 50 ft line set is used -- 9 additional feet x 0.22 oz per ft = Add 1.98 oz. of R410A.

Figure 56: Typical LC369HV and LC429HV System Layout.

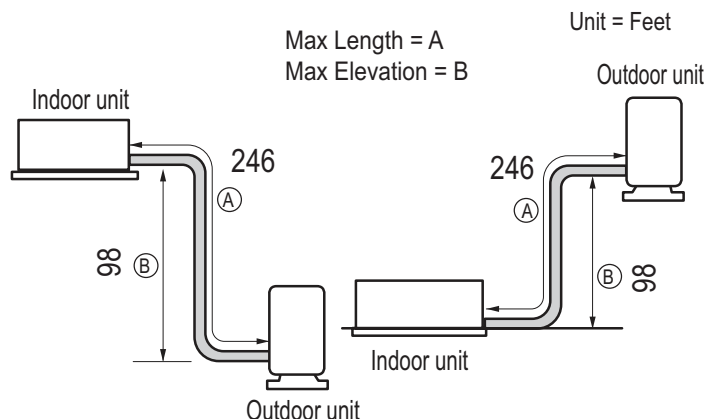

Inverter



LG Electronics, U.S.A., Inc.
Air Conditioning Technologies
4300 North Point Parkway
Alpharetta, Georgia 30022
www.lghvac.com

EM_SZ_Cassette_0HV_06_24
Supersedes: EM_SZ_Cassette_0HV_02_24
EM_SZ_Cassette_0HV_11_23
EM_SZ_Cassette_0HV_08_23A
EM_SZ_Cassette_0HV_08_23
EM_SZ_Cassette_0HV_07_23
EM_SZ_Cassette_02_23
EM_SZ_Cassette_12_22
EM_SZ_Cassette_06_21
EM_SZ_Cassette_05_21
EM_SZ_Cassette_04_21
EM_SZ_Cassette_10_20
EM_SZ_Cassette_09_20
EM_SZ_Cassette_09_19
EM_SZ_Cassette_2_19
EM_SZ_Cassette_12_18
EM_SZ_Cassette_11_18
EM_SZ_Cassette_8_17
EM_SZ_Cassette_7_16
DFS-EM-AC-001-US_014D02